



# X3-AELIO

50 kW / 60 kW / 49.9 kW / 61 kW

## User Manual

Version 0.0

[www.solaxpower.com](http://www.solaxpower.com)



Manual of the X3-AELIO inverter  
http://www.solaxpower.com/

# STATEMENT

---

## Copyright

Copyright © SolaX Power Network Technology (Zhejiang) Co., Ltd. All rights reserved.

No part of this manual may be reproduced, transmitted, transcribed, stored in a retrieval system, or translated into any language or computer language, in any form or by any means without the prior written permission of SolaX Power Network Technology (Zhejiang) Co., Ltd.

## Trademarks



**SOLA<sub>X</sub>** and other symbol or design (brand name, logo) that distinguishes the products or services offered by SolaX has been trademark protected. Any unauthorized use of the above stated trademark may infringe the trademark right.

## Notice

Please note that certain products, features, and services mentioned in this document may not be within the scope of your purchase or usage. Unless otherwise specified in the contract, the contents, information, and recommendations presented in this document are provided "as is" by SolaX. We do not provide any warranties, guarantees, or representations, whether express or implied.

The content of the documents is reviewed and updated as needed. However, occasional discrepancies may occur. SolaX retains the right to make improvements or changes in the product(s) and the program(s) described in this manual at any time without prior notice.

The images included in this document are solely for illustrative purposes and may differ based on the specific product models.

For more detailed information, kindly visit the website of SolaX Power Network Technology (Zhejiang) Co., Ltd. at [www.solaxpower.com](http://www.solaxpower.com).

SolaX retains all rights for the final explanation.

# About This Manual

---

## Scope of Validity

This manual is an integral part of X3-AELIO series inverter. It describes the transportation, storage, installation, electrical connection, commissioning, maintenance and troubleshooting of the product. Please read it carefully before operating.

This manual is valid for the following inverter models:

- X3-AELIO-50K
- X3-AELIO-60K
- X3-AELIO-49.9K
- X3-AELIO-61K
- X3-AELIO-49.9K-P

Model description

## X3-AELIO-49.9K-P

1

2

3

Item	Meaning	Description
1	Product family name	"X3-AELIO": energy storage series inverter that supports grid connection of photovoltaic system.
2	Power	"49.9K": rated output power of 49.9 kW.
3	Plus version	Plus version has one more MPPT compared to normal version.



## Target Group

The installation, maintenance and grid-related setting can only be performed by qualified personnel who:

- Are licensed and/or satisfy state and local jurisdiction regulations.
- Have good knowledge of this manual and other related documents.

## Conventions

The symbols that may be found in this manual are defined as follows.

Symbol	Description
 DANGER	Indicates a hazardous situation which, if not avoided, will result in death or serious injury.
 WARNING	Indicates a hazardous situation which, if not avoided, could result in death or serious injury.
 CAUTION!	Indicates a hazardous situation which, if not avoided, could result in minor or moderate injury.
NOTICE!	Provides tips for the optimal operation of the product.

## Change History

Version 00 (2024-07-08)

Initial release

# Table of Contents

---

1	Safety	1
1.1	General Safety	1
1.2	Safety Instructions of PV, Inverter and Grid	1
1.2.1	Safety Instructions of PV	2
1.2.2	Safety Instructions of Inverter	2
1.2.3	Safety Instructions of Utility Grid	3
2	Product Overview	4
2.1	Product Introduction	4
2.2	Appearance	4
2.3	Supported Power Grid	5
2.4	Symbols on the Label and Inverter	7
2.5	Working Principle	8
2.5.1	Circuit Diagram	8
2.5.2	Application Schemes	9
2.6	Working State	11
2.7	Working Mode	12
2.7.1	Self-use Mode (Priority: Loads > Battery > Grid)	12
2.7.2	Feed-in Priority (Priority: Loads > Grid > Battery)	14
2.7.3	Backup Mode (Priority: Loads > Battery > Grid)	15
2.7.4	Peak Shaving Mode	16
2.7.5	TOU Mode	18
2.7.6	EPS Mode (Priority: Loads > Battery)	19
2.7.7	Manual Mode	20
2.7.8	Export Control Function	20
3	System Overview	22
4	Transportation and Storage	24
5	Preparation before Installation	25
5.1	Selection of Installation Location	25
5.1.1	Environment Requirement	25
5.1.2	Installation Carrier Requirement	27
5.1.3	Clearance Requirement	27
5.2	Tools Requirement	29
5.3	Additionally Required Materials	30

<b>6</b>	<b>Unpacking and Inspection .....</b>	<b>32</b>
6.1	Unpacking.....	32
6.2	Scope of Delivery.....	33
<b>7</b>	<b>Mechanical Installation .....</b>	<b>36</b>
7.1	Dimensions for mounting.....	37
7.2	Installation procedures.....	38
7.2.1	Wall mounting procedures.....	38
7.2.2	Cabinet installation procedures.....	42
7.2.3	Inverter screen cover installation.....	47
<b>8</b>	<b>Electrical Connection .....</b>	<b>49</b>
8.1	Terminals of Inverter.....	49
8.2	PE Connection.....	50
8.3	AC Connection.....	53
8.4	PV Connection.....	61
8.5	Battery Power Cable Connection.....	67
8.6	COM 1 Communication Connection.....	74
8.6.1	Pin Assignment of COM 1 Terminal.....	74
8.6.2	Parallel Connection.....	75
8.6.3	BMS Communication Connection.....	78
8.6.4	RS485 Communication Connection.....	80
8.6.5	DRM Connection (Applicable to AS/NZS 4777).....	82
8.7	COM 2 Communication Connection.....	84
8.7.1	Pin Assignment of COM 2 Terminal.....	84
8.7.2	Meter/CT Connection.....	85
8.7.3	Ripple Control Communication Connection.....	93
8.7.4	DIO Communication Connection.....	95
8.8	Monitoring Connection.....	97
<b>9</b>	<b>System Commissioning.....</b>	<b>100</b>
9.1	Checking before Power-on.....	100
9.2	Powering on the System.....	100
9.3	Checking after Powering on.....	101
<b>10</b>	<b>Operation on LCD.....</b>	<b>102</b>
10.1	Introduction of Control Panel.....	102
10.2	Introduction of Menu Interface.....	103
10.3	System ON/OFF.....	106
10.4	Mode Select.....	106
10.5	System Status.....	106

10.6 Parallel Status .....	108
10.7 History Data .....	108
10.8 Setting .....	111
10.8.1 User Setting .....	111
10.8.2 Advance Setting .....	118
10.9 About .....	136
<b>11 Troubleshooting and Maintenance .....</b>	<b>137</b>
11.1 Power off .....	137
11.2 Operation of Lockable DC Switch (for Australia Version Only) .....	137
11.3 Troubleshooting .....	140
11.4 Maintenance .....	148
11.4.1 Maintenance routines .....	148
11.4.2 Replacement of Fans .....	148
11.4.3 Upgrading Firmware .....	151
<b>12 Decommissioning .....</b>	<b>154</b>
12.1 Disassembling the Inverter .....	154
12.2 Packing the Inverter .....	158
12.3 Disposing of the Inverter .....	158
<b>13 Technical Data .....</b>	<b>159</b>
<b>14 Appendix .....</b>	<b>163</b>
14.1 Generator Application .....	163
14.1.1 Introduction of generator application .....	163
14.1.2 Notice for generator application .....	163
14.1.3 ATS control mode .....	163
14.1.4 Dry contact mode .....	165
14.2 Adapter Box Application .....	169
14.2.1 Introduction of Adapter Box application .....	169
14.2.2 Wiring connection diagram .....	169
14.2.3 Communication connection with inverter .....	170
14.2.4 Settings for Adapter Box .....	171
14.3 EV-Charger Application .....	172
14.3.1 Introduction of EV-Charger application .....	172
14.3.2 Wiring connection diagram .....	172
14.3.3 Charging modes .....	172
14.3.4 Communication connection with inverter .....	173
14.3.5 Setting for EV-Charger .....	174
14.4 Micro-grid Application .....	175

14.4.1	Introduction of Micro-grid application.....	175
14.4.2	Wiring conenction diagram.....	175
14.4.3	Working modes.....	176
14.4.4	Cable connection (Hybrid inverter).....	178
14.4.5	Cable connection (On-grid inverter).....	178
14.4.6	Cable connection (Meter).....	178
14.5	Application of Parallel Function.....	181
14.5.1	Introduction of parallel application.....	181
14.5.2	Notice for parallel application.....	181
14.5.3	System wiring diagram.....	182
14.5.4	System wiring procedure.....	184
14.5.5	Settings for parallel connection.....	187

# 1 Safety

---

## 1.1 General Safety

The series inverter has been meticulously designed and thoroughly tested to comply with all relevant state and international safety standards. Nevertheless, like all electrical and electronic equipment, safety precautions must be observed and followed during the installation of the inverter to minimize the risk of personal injury and ensure a safe installation.

Please thoroughly read, comprehend, and strictly adhere to the comprehensive instructions provided in the user manual and any other relevant regulations prior to the installation of the inverter. The safety instructions in this document serve as supplementary guidelines to local laws and regulations.

SolaX shall not be liable for any consequences resulting from the violation of the storage, transportation, installation, and operation regulations outlined in this document. Such consequences include, but are not limited to:

- Inverter damage caused by force majeure events, such as earthquakes, floods, thunderstorms, lightning, fire hazards, volcanic eruptions, and similar events.
- Inverter damage due to human causes.
- Usage or operation of the inverter in violation of local policies or regulations.
- Failure to comply with the operation instructions and safety precautions provided with the product and in this document.
- Improper installation or usage of the inverter in unsuitable environmental or electrical conditions.
- Unauthorized modifications to the product or software.
- Inverter damage occurring during transportation by the customer.
- Storage conditions that do not meet the requirements specified in this document.
- Installation and commissioning performed by unauthorized personnel who lack the necessary licenses or do not comply with state and local jurisdiction regulations.

## 1.2 Safety Instructions of PV, Inverter and Grid

Save these important safety instructions. Failure to do so may result in damage to the inverter and injury or even loss of life.

### 1.2.1 Safety Instructions of PV



**Potential risk of lethal electrical shock associated with the photovoltaic (PV) system**

- Exposure to sunlight can result in the generation of high DC voltage by PV modules, which can lead to electric shock causing severe injuries or even death.
- Never touch the positive or negative poles of the PV connecting device, and avoid touching both poles simultaneously.
- Do not ground the positive or negative poles of the PV modules.
- Only qualified personnel can perform the wiring of the PV modules.



- Overvoltage protection with surge arresters should be provided when the PV system is installed. The grid connected inverter is fitted with SPDs on both PV input side and MAINS side.
- Please consult professionals before installing SPDs.



- Make sure that the input DC voltage does not exceed the maximum DC input voltage specified for the inverter. Overvoltage can cause irreversible damage to the inverter, and such damage is not covered by the warranty.

### 1.2.2 Safety Instructions of Inverter



**Potential risk of lethal electrical shock associated with the inverter**

- Only operate the inverter if it is in a technically faultless condition. Operating a faulty inverter may lead to electric shock or fire.
- Do not attempt to open the enclosure without authorization from SolaX. Unauthorized opening of the enclosure will void the warranty and can result in lethal danger or serious injury due to electric shock.
- Make sure that the inverter is reliably grounded before any operation to prevent the risk of electric shock causing lethal danger or serious injury.
- Only qualified personnel can perform the installation, wiring, maintenance of the inverter by following this document and the related regulations.



- Prior to any wiring connection, establishing an earth connection is essential.

 **WARNING!**

- During operation, avoid touching any parts of the inverter other than the DC switch and LCD panel.
- Never connect or disconnect the AC and DC connector while the inverter is running.
- Prior to conducting any maintenance, turn off the AC and DC power and disconnect them from the inverter. Wait for 5 minutes to fully discharge the energy.

 **WARNING!****Potential danger of scalding due to the hot enclosure of the inverter**

- Avoid touching the inverter while it is running, as it becomes hot during operation and may cause personal injuries.

 **WARNING!**

- When handling the battery, carefully follow all safety instructions provided in the battery manual. The battery used with the inverter must meet the specified requirements of the series inverter.

 **CAUTION!**

- Make sure that children are supervised to prevent them from playing with the inverter.
- Pay attention to the weight of the inverter and handle it properly to avoid personal injuries.
- Use insulated tools when installing the device, and always wear personal protective equipment during installation and maintenance.

**NOTICE!**

- If an external Residual Current Device (RCD) is required by local regulations, verify the type of RCD required. It is recommended to use a Type-A RCD with a rating of 300 mA unless a lower value is required by the specific local electric codes. When required by local regulations, the use of an RCD type B is permitted.
- Keep all product labels and the nameplate on the inverter clearly visible and well-maintained.

### 1.2.3 Safety Instructions of Utility Grid

**NOTICE!**

- Only connect the inverter to the grid with the permission of the local utility grid company.

## 2 Product Overview

### 2.1 Product Introduction

The X3-AELIO series is a versatile inverter that includes the function of solar charging, battery charging and more. It supports various intelligent solutions such as load management, wireless metering, dual battery terminals, microgrids, etc. to achieve efficient and economical energy utilization. The X3-AELIO series inverter can be used with different capacities of SolaX battery.

### 2.2 Appearance

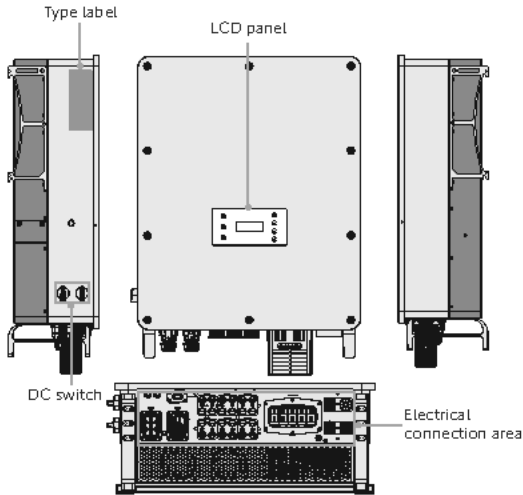

Figure 2-1 Appearance

Table 2-1 Description of appearance

Item	Description
Type label	Type label clearly identifies the device type, serial number, specific DC / AC parameters, certification, etc.
LCD panel	Including screen, indicators and keys. Screen displays the information; indicators indicate the status of inverter. Keys are used to perform the parameter setting.
DC switch	Disconnect the PV DC input when necessary. DC switch 1 controls MPPT 1, 2 and 3, DC switch 2 controls MPPT 4, 5 and 6.

Item	Description
Electrical connection area	Including PV terminals, battery terminals, Grid and EPS terminals, communication terminals, etc.

## 2.3 Supported Power Grid

There are different ways of wiring for different grid systems. TT / TN-S / TN-C-S are shown below:

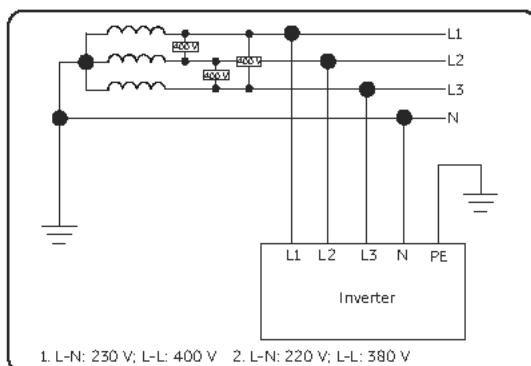

Figure 2-2 Supported power grid-TT

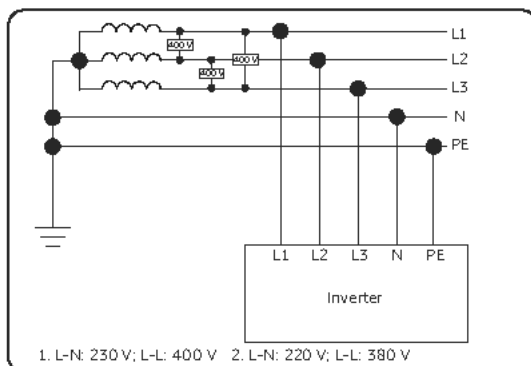

Figure 2-3 Supported power grid-TN-S

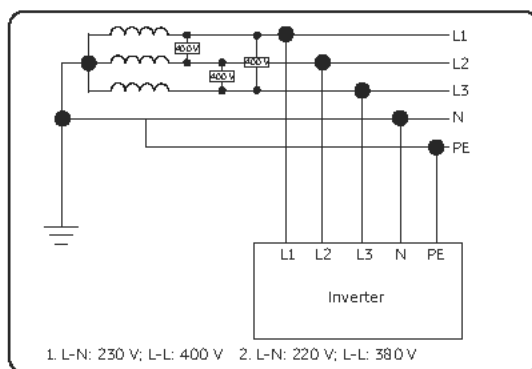













Figure 2-4 Supported power grid-TN-C-S

**NOTICE!**

- If a different power grid is required, please consult our SolaX after-sales team for confirmation.

## 2.4 Symbols on the Label and Inverter

Table 2-2 Description of symbols

Symbol	Description
	CE mark. The inverter complies with the requirements of the applicable CE guidelines.
	TUV certified.
	RCM mark. The inverter complies with the requirements of the applicable RCM guidelines.
	Additional grounding point
	Beware of hot surface. Do not touch a running inverter, as the inverter becomes hot during operation!
	Risk of electric shock. High voltage exists after the inverter is powered on!
	Risk of danger Potential hazards exist after the inverter is powered on!
	Observe enclosed document.
	The inverter can not be disposed together with the household waste.
	Do not operate this inverter until it is isolated from battery, mains and on-site PV generation source.
	Danger to life due to high voltage. Residual voltage exists after the inverter is powered off, which needs 5 minutes to fully discharge. Wait 5 minutes before attempting any service.

## 2.5 Working Principle

### 2.5.1 Circuit Diagram

The inverter is equipped with multi-channel MPPT for DC input to ensure maximum power even under different photovoltaic input conditions. The inverter unit converts direct current into alternating current that meets the requirements of the power grid and feeds it into the power grid. The lightning arrester at AC / DC side realizes the function of surge protection. The principle design of inverter is shown in the figure below:

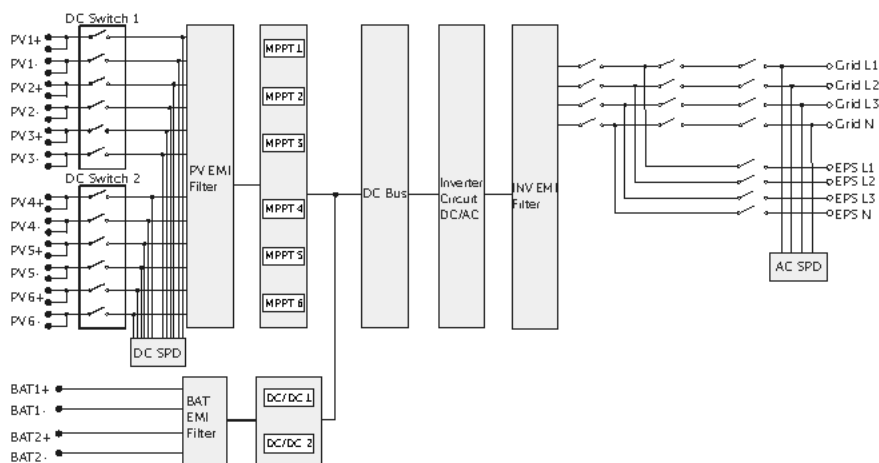

Figure 2-5 Circuit Diagram for X3-AELIO series inverter

#### NOTICE!

- MPPT 6 is unavailable for the X3-AELIO-50K and X3-AELIO-49.9K inverter but available for the X3-AELIO-60K, X3-AELIO-61K and X3-AELIO-49.9K-P inverter.

## 2.5.2 Application Schemes

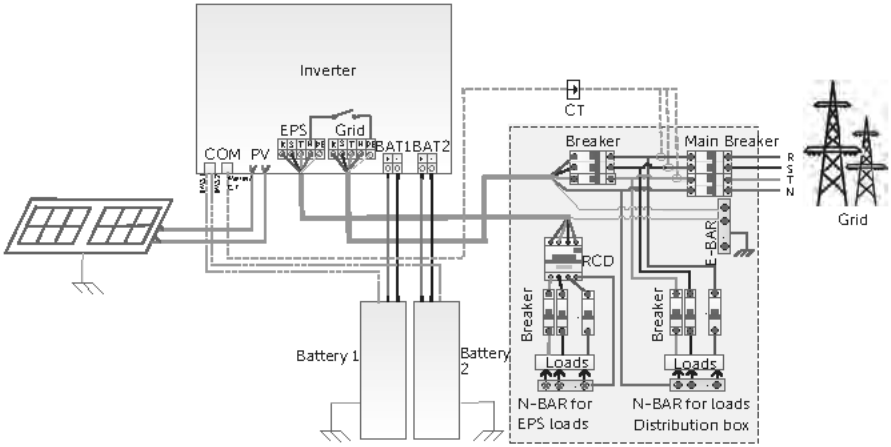

Figure 2-6 Partial home backup for Europe

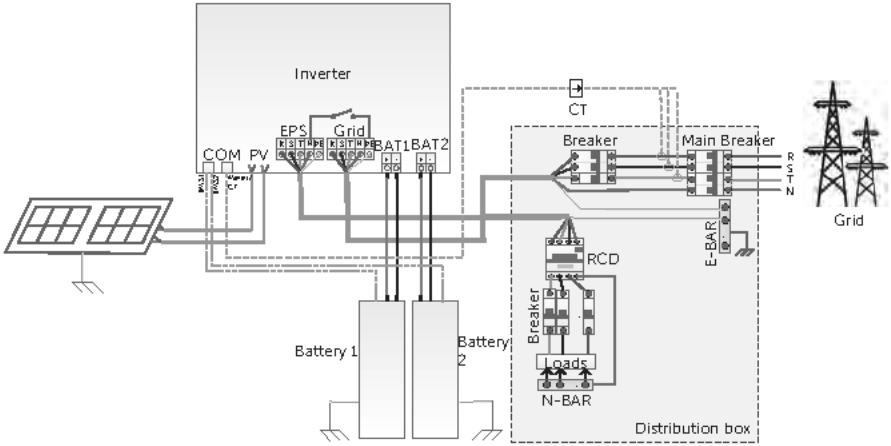

Figure 2-7 Whole home backup for Europe

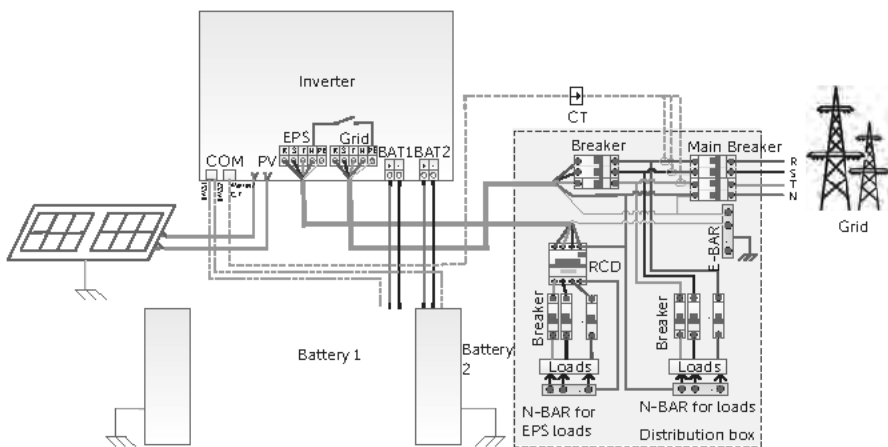

Figure 2-8 Partial home backup for Australia

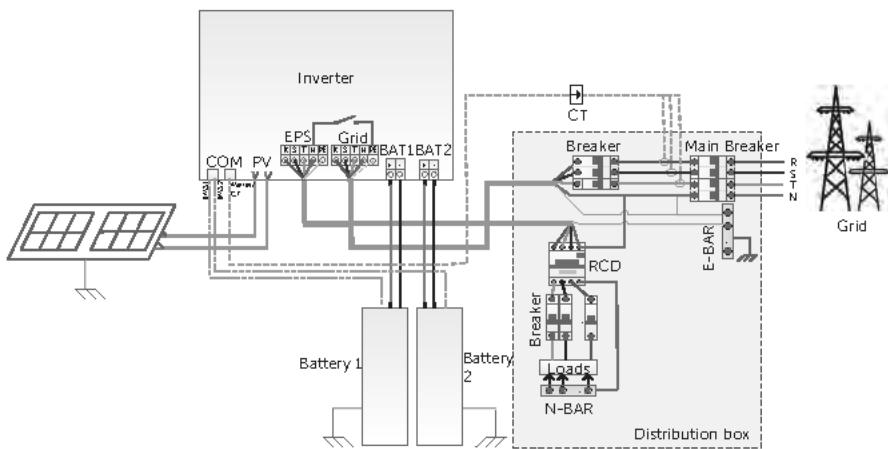

Figure 2-9 Whole home backup for Australia

**NOTICE!**

- The BAT 1 and BAT2 terminals of the inverter are positioned vertically, with the positive pole on the left side and the negative pole on the right side. The battery terminals shown in the figure above are for illustrative purposes only, please refer to the actual product for accurate information.

## 2.6 Working State

The series inverter has Waiting, Checking, Normal, EPS Checking, EPS, Fault, Idle and Standby state.

Table 2-3 Description of working state

State	Description
Waiting	The inverter is waiting for the conditions to be met in order to enter the Checking state.
Checking	<ul style="list-style-type: none"> <li>The inverter is checking for conditions to enter Normal state.</li> </ul>
Normal	<ul style="list-style-type: none"> <li>The inverter is working normally.</li> </ul>
EPS Checking	<ul style="list-style-type: none"> <li>The inverter is checking for conditions to enter EPS state.</li> </ul>
EPS	<ul style="list-style-type: none"> <li>The inverter is working in off-grd state.</li> </ul>
Fault	<ul style="list-style-type: none"> <li>The inverter detects error occurred and prompts error code.</li> </ul>
Idle	<ul style="list-style-type: none"> <li>A standby state when the the battery SOC reaches the minimum SOC and there is no sufficient PV input voltage.</li> </ul>
Standby	<ul style="list-style-type: none"> <li>A standby state when the power of load is extremely low and there is no sufficient PV input voltage, or a state when the battery SOC is less than or equal to 10% and there is no sufficient PV input voltage.</li> <li>In this state, it detects PV connection, load power, battery forced charged, etc to determine whether to exit Standby state and enter Normal state.</li> </ul>

### NOTICE!

- When the inverter is in an Idle state, you can reset the work mode, the Min SOC and the charging periods through the inverter LCD or the SolaX APP to charge the battery to the Min SOC in the charging periods and then awaken the inverter. Please make sure that the actual battery SOC - the modified Min SOC  $\geq$  2% under a specific work mode, so that other modifications are effective. When the current system time is within the new charging periods you reset, the battery begins charging.

## 2.7 Working Mode

Six working modes are available for you to choose in on-grid status, i.e Self use, Feed-in priority, Backup, Peak shaving, Schedule and Manual. You can choose the working modes according to your lifestyle and environment.

When the power supply from the electric power company is stopped due to a power outage, it automatically switches to EPS mode and connects to the distribution board for a specific load, thereby providing power to important electrical appliances.

For how to set the working mode, please refer to the section "10.8.1 User Setting".

### 2.7.1 Self-use Mode (Priority: Loads > Battery > Grid)

The self-use mode is suitable for areas with low feed-in subsidies and high electricity prices. The power of PV will supply the loads first, and the surplus power will charge the battery, then the remaining power will feed into the grid.

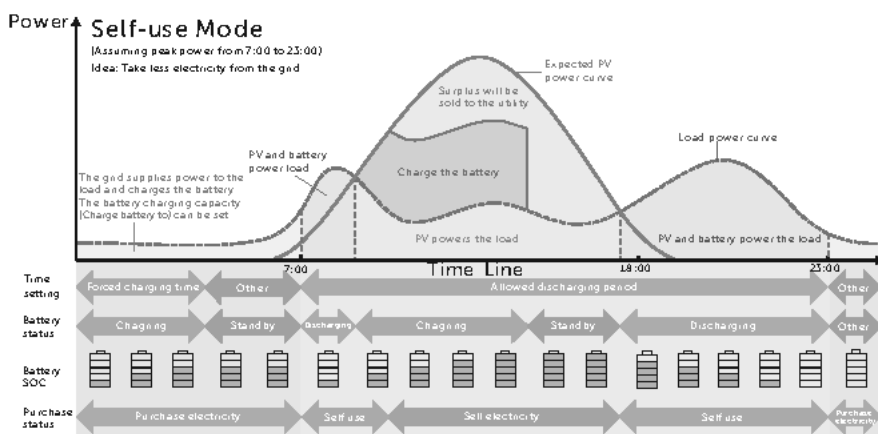

Figure 2-10 Self-use mode

Table 2-4 Description of self-use mode

Time period	Inverter working status
Forced charging period	<ul style="list-style-type: none"> <li>Charge the battery firstly until the battery SOC reaches the specified <b>Charge battery to</b> value. You can configure the inverter to either draw power from the grid or not.</li> </ul>

Time period	Inverter working status
Allowed discharging period	PV is sufficient (PV → load → battery → grid) <ul style="list-style-type: none"> <li>The power generated from PV prioritizes supplying the load. Any excess power is then directed towards charging the battery, and if there is still surplus electricity, it can be sold to the grid. In the event that the local utility restricts the sale of electricity to the grid, the export control value can be set on the inverter.</li> </ul>
	PV is insufficient (PV+battery → load) <ul style="list-style-type: none"> <li>The battery discharges power to the load, and once its capacity reaches <b>Min SOC</b>, it automatically ceases discharging.</li> </ul>

Note:

**Charge battery to:** The battery SOC charged from grid. 10% by default, the settable range is 10%~100%.

**Min SOC:** Minimum SOC of the battery under grid connection. 10% by default, the settable range is 10%~100%.

## Charge & Discharge Period

You can set two configurable working periods: forced charging period and allowed discharging period. The interval not in the charging & discharging period belongs to other time periods.

- Forced charging period (Default period: 00:00~00:00, closed by default)

The priority of forced charging period is higher than all working modes. In the forced charging period, the inverter will charge the battery first until the battery SOC reaches the specified **Charge battery to** value set in each working mode. You have the option to configure the inverter to either draw power from the grid or not.

- Allowed discharging period (Default period: 00:00~23:59)

In the allowed discharging period, the inverter will allow the battery to discharge and charge power in accordance with the working mode and load conditions.

- Period not set as forced charging or allowed discharging period

In this period, the inverter will allow the battery to charge but can not discharge power.

### NOTICE!

- The charging and discharging period is only applicable for self-use mode, feed-in priority and backup mode.

## 2.7.2 Feed-in Priority (Priority: Loads > Grid > Battery)

The feed-in priority mode is suitable for areas with high feed-in subsidies, but has feed-in power limitation. The power generated from PV is directed towards supplying the loads. Any excess power beyond the load requirements will be fed into the grid.

Note: If the amount of electricity sold to the grid is limited, the remaining power will be utilized to charge the battery.

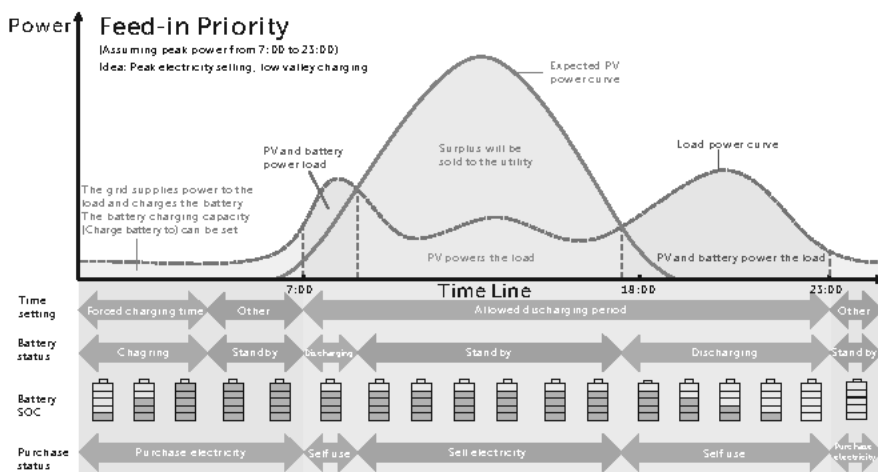

Figure 2-11 Feed-in priority

Table 2-5 Description of feed-in priority

Time period	Inverter working status
Forced charging period	<ul style="list-style-type: none"> <li>Charge the battery firstly until the battery SOC reaches the specified <b>Charge battery to</b> value. You can configure the inverter to either draw power from the grid or not.</li> </ul>
Allowed discharging period	<p>PV is sufficient (PV → load → grid)</p> <ul style="list-style-type: none"> <li>The power generated from PV is directed towards supplying the loads. Any excess power beyond the load requirements will be fed into the grid,</li> </ul> <p>PV is insufficient (PV+battery → load)</p> <ul style="list-style-type: none"> <li>PV and battery supply power to the load at the same time, and once the battery capacity reaches <b>Min SOC</b>, it automatically ceases discharging.</li> </ul>

Note:

**Charge battery to:** The battery SOC charged from grid. 50% by default, the settable range is 10%~100%.

**Min SOC:** Minimum SOC of the battery under grid connection. 10% by default, the settable range is 10%~100%.

### NOTICE!

- You can set two configurable working periods: forced charging period and allowed discharging period in feed-in priority mode. Please refer to "Charge & Discharge Period" for details.

## 2.7.3 Backup Mode (Priority: Loads > Battery > Grid)

The backup mode is suitable for areas with frequent power outages.

This mode will maintain the battery capacity at relatively high level to ensure that the emergency loads can be used when grid is off. Same working logic with self-use mode.

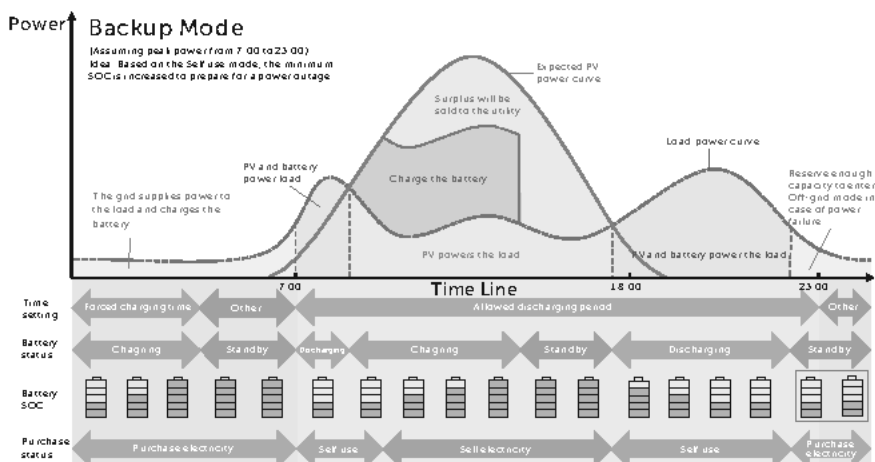

Figure 2-12 Backup mode

Table 2-6 Description of backup mode

Time period	Inverter working status
Forced charging period	<ul style="list-style-type: none"> <li>Charge the battery firstly until the battery SOC reaches the specified <b>Charge battery to</b> value. You can configure the inverter to either draw power from the grid or not.</li> </ul>
Allowed discharging period	<ul style="list-style-type: none"> <li>The working logic remains the same as for self-use mode, but it enters a standby state when PV input is not available and the battery SOC reaches <b>Min SOC</b> (on-grid min SOC). In the event of a grid outage, it will switch to EPS mode until the battery discharges to <b>Min SOC</b> (Off-grid min SOC).</li> </ul>

Note:

**Min SOC (on-grid min SOC):** Minimum SOC under grid connection. 30% by default, the settable range is 30%~100%.

**Min SOC (off-grid min SOC):** Minimum SOC under off-grid conditions. 10% by default, the settable range is 10%~100%.

**NOTICE!**

- You can set two configurable working periods: forced charging period and allowed discharging period in backup mode. Please refer to "Charge & Discharge Period" for details.

## 2.7.4 Peak Shaving Mode

Peak shaving mode is set for leveling out peaks in electricity use. The system is intelligently controlled to ensure charging takes place during off-peak hours and discharging occurs during peak hours.

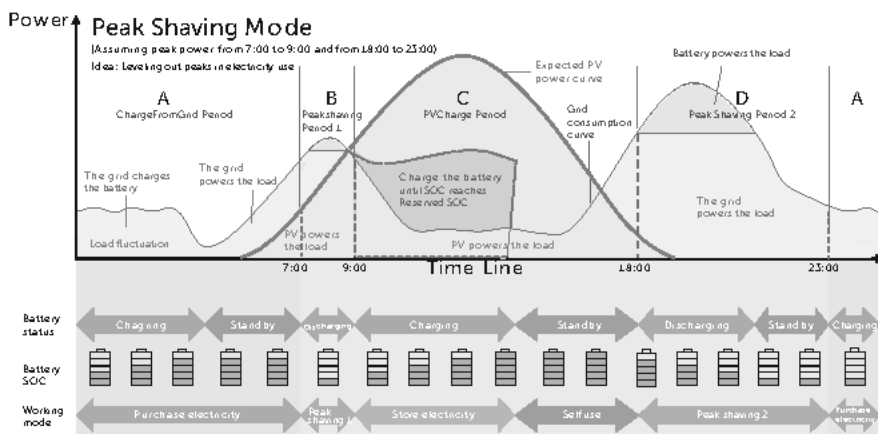

Figure 2-13 Peakshaving mode

Table 2-7 Description of peakshaving mode

Time Period	Inverter working status
Period A	<ul style="list-style-type: none"> <li>The grid can charge the battery to <b>MaxSOC</b> within the set <b>ChargePowerLimits</b>. In this period, the battery will not discharge power.</li> </ul>

Time Period	Inverter working status
Period B & D	Grid consumption power < <b>PeakLimits</b> (PV+grid → load) <ul style="list-style-type: none"> <li>The PV and grid will power the load. The battery will not charge or discharge power.</li> </ul>
	Grid consumption power > <b>PeakLimits</b> (PV + battery+grid → load) <ul style="list-style-type: none"> <li>The battery will discharge energy for loads and thus reduce the amount of energy purchased from the grid.</li> </ul>
Period C	(PV → battery → load → grid) <ul style="list-style-type: none"> <li>The battery does not discharge power. The PV charges the battery up to the <b>Reserved SOC</b> before supplying power to the loads. Any excess power beyond the load requirements is fed into the grid.</li> </ul>

Note:

**MaxSOC:** The energy taken from grid to charge the battery. 50% by default, the settable range is 10%-100%.

**ChargePowerLimits:** The charging power from grid. 1000 W by default, the settable range is 0-60000 W

**PeakLimits:** The load consumption from grid side. 0 W by default, the settable range: 0-60000 W.

**Reserved SOC:** The lower limit of battery SOC required for later peak shaving period. 50% by default, the settable range is 10~100%.

## 2.7.5 TOU Mode

In the TOU mode, different working modes, i.e Self-use, Charging, Discharging, Peaking shaving and Battery off can be set for different time periods in accordance with actual needs and environment conditions through SolaX Cloud App or Web.

The day can be divided into up to 24 time slots, and the minimum time slot is 15 minutes, independent working mode can be set for each time slot. Please refer to Web Guide or App Guide for details about how to set the TOU mode.

Time Slot	Working Mode
x:xx~x:xx (e.g 0:00~0:15)	Choose one mode from Self-use / Charging / Discharging / Battery off / Peaking shaving

Note:

Self-use: Same working logic with "Self-use Mode", but it is not limited by the charging and discharging time slots. The priority of PV: Loads > Battery > Grid.

Charging: The power of PV will charge the battery as much as possible to the set SOC of **Charge BAT to (%)**. You can set whether to Charge from grid. The default value of **Charge BAT to (%)** is 100%. When the battery reaches the set SOC, the surplus power will perform "Self-use Mode" or supply to the grid ( based on the system setup), at this point, **Charge from grid** is not allowed.

Discharging: If allowed by the battery, the system outputs a specified power from the grid based on the set output percentage, controlling the power at the AC port. You need to set the **RatePower (%)** through Web or App when choosing Discharging mode. When the battery **Discharge to (%)** reaches the set SOC, the inverter performs "Self-use Mode".

Peak Shaving: The working logic is that when the power consumption from the grid exceeds the set **PeakLimit** value, the battery is allowed to discharge power. The excess power beyond the limit is provided by the combination of photovoltaic and battery to ensure that the maximum power purchased from the grid does not exceed the set limit. You need to set the **PeakLimit** value through Web or App when choosing Peak Shaving mode.

Battery off: The battery neither charges nor discharges. The power of PV will supply to loads or the grid. Only when the battery SOC is lower than the system (TOU) **Min SOC**, the battery can be charged.

## 2.7.6 EPS Mode (Priority: Loads > Battery)

During a power failure, the system will provide uninterrupted power supply to the EPS loads using the power from PV and the battery. It is important to ensure that a battery is installed, and the EPS loads should not exceed the maximum output power of the battery.

The power generated by PV will prioritize supplying power to the loads, while any surplus power will be utilized to charge the battery.

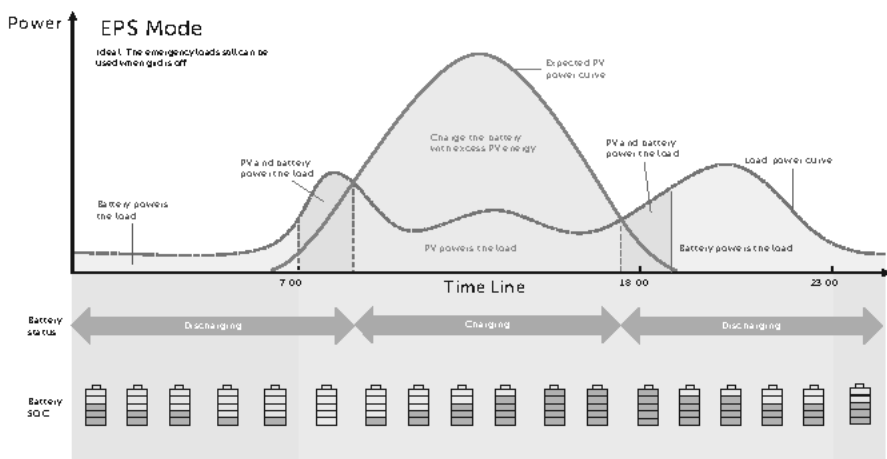

Figure 2-14 EPS mode

Table 2-8 Description of EPS mode

Battery SOC	Inverter working status
Battery SOC > Min SOC (off-grid min SOC)	PV is sufficient (PV → load → battery)
	<ul style="list-style-type: none"> <li>The PV prioritizes supplying power to the load, with any excess energy being directed towards charging the battery.</li> </ul>
Battery SOC ≤ Min SOC (off-grid min SOC)	PV is insufficient (PV+battery → load)
	<ul style="list-style-type: none"> <li>The PV prioritizes supplying power to the load. If the energy is not enough, the battery will discharge power until the battery SOC reaches <b>Min SOC</b> and then error of <b>BatPowerLow</b> will be reported.</li> </ul>
Battery SOC ≤ Min SOC (off-grid min SOC)	The inverter reports <b>BatPowerLow</b> . When there is PV, it will charge the battery first. After charging to the set <b>Min ESC SOC</b> value, it will be automatically recovered and enter EPS mode again.

Note:

**Min SOC:** Minimum SOC of the battery under off-grid conditions. 10% by default, the settable range: 10%-100%.

**Min ESC SOC:** The minimum SOC of the battery to enter EPS mode. 30% by default, the settable range: 15%-100%.

## 2.7.7 Manual Mode

This working mode is only for the after-sales team to do after-sales maintenance. It includes **Forced Discharge**, **Forced Charge** and **Stop chrg&dischrg**. The system will restore to the original working mode after six hours Manual mode set.

## 2.7.8 Export Control Function

Solar export control is a limit on the amount of energy that your solar system can export into the grid. You have a set limit on how much energy you can export to the grid.

### How Export Control works

- CT/meter required
- Correct setting of the limit value of **Export Control** through inverter. (For parallel system, set on the master inverter)

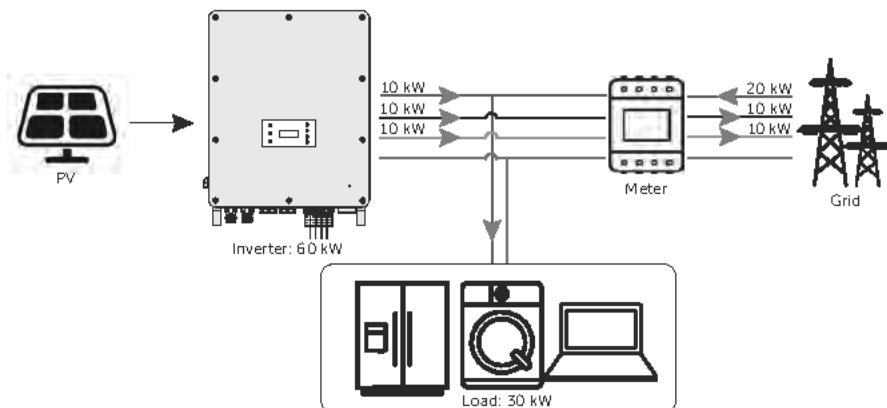

Figure 2-15 Zero export control with **Phase Unbalance** disabled

### NOTICE!

- The power taken from the grid is equal to the power fed into the grid.

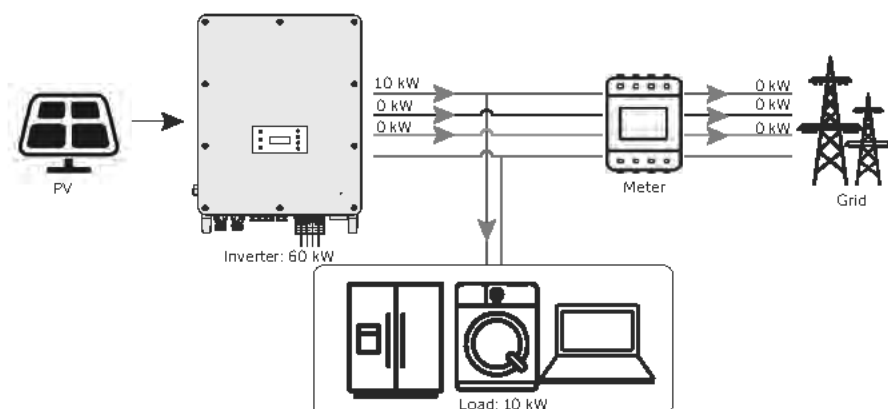

Figure 2-16 Zero export control with **Phase Unbalance** enabled

Note:

**Export Control** value can be set from 0W to more than the rated output power.

For how to set the **Export Control** function, please refer to "Setting Export Control".



Item	Description
Battery	The series inverter should be coupled with two clusters of lithium-ion batteries. The BAT1 and BAT2 terminals of the inverter can be connected to clusters of batteries of different capacities and numbers of batteries. It communicates with the inverter via BMS and must comply with the specifications of the regulations.
Meter/CT	The meter/CT is used by the inverter for import / export or consumption readings, and manages the battery charge / discharge accordingly for smart energy management applications.
Additional on-grid inverter (supported)	The inverter supports micro-grid function that makes hybrid inverter simulate the grid to active on-grid inverter during off-grid period by connecting on-grid inverter to hybrid inverter's EPS terminal. Please refer to "14.4 Micro-grid Application" for specific wiring and setting. The nominal power of the on-grid inverter should be no more than that of the EPS terminal of X3-AELIO inverter.
Adapter Box (supported)	With SolaX Adapter Box, you can connect the smart heat pump to the energy storage systems, realizing the control of the heat pump through inverter. Please refer to "14.2 Adapter Box Application" for specific wiring and setting.
EV-Charger (supported)	The inverter can communicate with SolaX EV-Charger to form an intelligent photovoltaic, storage and EV charging energy system, thus maximizing the utilization of photovoltaic energy. Please refer to "14.3 EV-Charger Application" for specific wiring and setting.
Generator (supported)	SolaX PV-Genset solution ensures optimum interaction between the photovoltaics and diesel generator, which saves fuel, lowers energy costs and ensures a stable and reliable power supply. Please refer to "14.1 Generator Application" for specific wiring and setting.
Grid	400 V / 230 V and 380 / 220 V grid are supported. Power grid TT, TN-C, TN-C-S can be supported.
SolaX Cloud	SolaX Cloud is an intelligent, multifunctional monitoring platform that can be accessed either remotely or through a hard wired connection. With the SolaX Cloud, the operators and installers can always view key and up-to-date data. There are two SolaX Cloud platforms. Household platform can be connected through monitoring dongle connection and commercial platform can be connected through EMS1000 connection.

## 4 Transportation and Storage

---

If the inverter is not put into use immediately, the transportation and storage requirements needs to be met:

### Transportation

- Observe the caution signs on the packaging of inverter before transportation.
- Pay attention to the weight of inverter. Be cautious to avoid injury when carrying X3-AELIO (gross weight: 130 kg). Lifting equipment is recommended.
- The inverter with a package should be transported by forklift to the location where it needs to be placed.

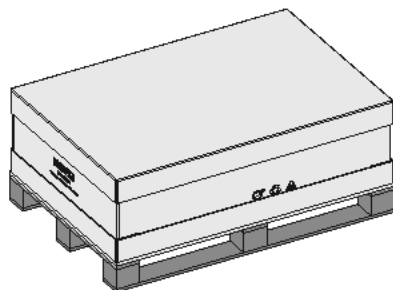

Figure 4-1 Caution signs on the packaging

### Storage

- The inverter must be stored indoors.
- Do not remove the original packaging material and check the outer packaging material regularly.
- The storage temperature should be between  $-40^{\circ}\text{C}$  and  $+70^{\circ}\text{C}$ . The humidity should be between 0% and 65%.
- Stack the inverter in accordance with the caution signs on the inverter carton to prevent their falling down and device damage. Do not place it upside down.

## 5 Preparation before Installation

### 5.1 Selection of Installation Location

The installation location selected for the inverter is quite critical in the aspect of the guarantee of machine safety, service life and performance. It has the IP66 ingress protection, which allows it to be installed outdoors. The installation position shall be convenient for wiring connection, operation and maintenance.

#### 5.1.1 Environment Requirement

Make sure the installation site meets the following conditions:

- The ambient temperature:  $-35^{\circ}\text{C}$  to  $+60^{\circ}\text{C}$ .
- The relative humidity shall be between 0-100%RH.
- Do not install the inverter in the areas where the altitude exceeds 3000 m.
- Install the inverter in a well-ventilated environment for heat dissipation. You are recommended to install an awning over the inverter if it is installed on a support outdoors.
- Do not install the inverter in areas with flammable, explosive and corrosive materials or near antenna.
- Avoid direct sunlight, rain exposure and snow laying up.

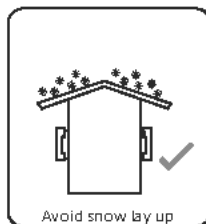
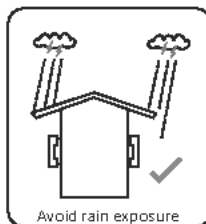
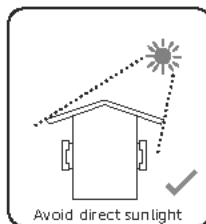
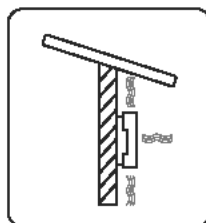
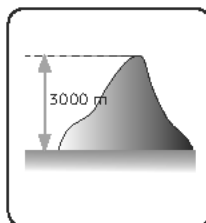
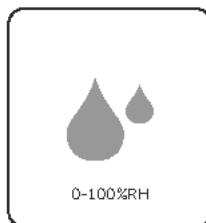
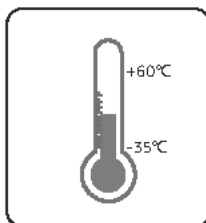

NOTICE!

- For outdoor installation, precautions against direct sunlight, rain exposure and snow accumulation are recommended.
- Exposure to direct sunlight raises the temperature inside the device. This temperature rise poses no safety risks, but may impact the device performance.
- Install the inverter at least 500 meters away from the coast and avoid sea breeze directly hit.

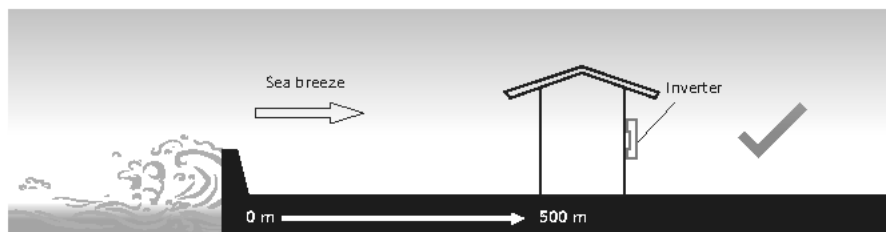

Figure 5-1 Recommended installation position

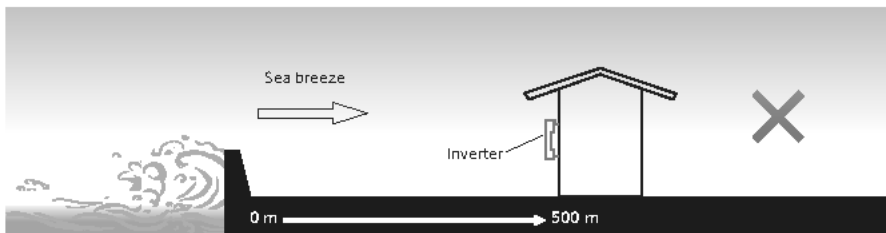

Figure 5-2 Incorrect installation position

NOTICE!

- For the installation of the whole system, please refer to the specific environment requirement of each unit.

### 5.1.2 Installation Carrier Requirement

The installation carrier must be made of a non-flammable material, such as solid brick, concrete, etc. and be capable of supporting the weight of the inverter and suitable of the dimensions of the inverter. If the wall strength is not enough, (such as wooden wall, the wall covered by thick layer of decoration) it must be strengthened additionally.

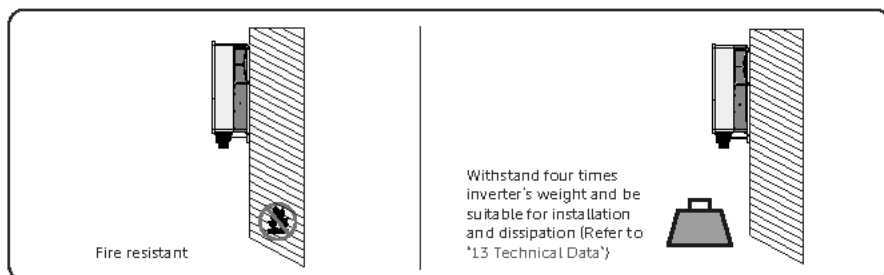

Figure 5-3 Installation carrier requirement

#### NOTICE!

- Please take the weight of battery into account when wall-mounting the whole system.

### 5.1.3 Clearance Requirement

The minimum clearance reserved for the connected terminal at the bottom of inverter and the bending radius of the wires should be no less than 80 cm.

To guarantee proper heat dissipation and ease of disassembly, the minimum space around the inverter must meet the standards indicated below.

For installations with multiple inverters, two installation modes are taken for an example below. When the space is sufficient, Figure 5-5 is recommended. When the space is insufficient, Figure 5-6 is recommended. Please make sure to leave the minimum space among inverters marked on the figure below. In areas with high ambient temperatures, increase the clearances between the inverters and provide adequate fresh air ventilation if feasible.

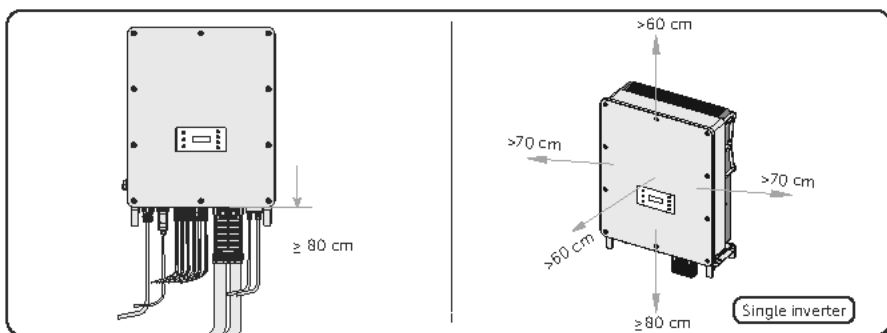

Figure 5-4 Clearance requirement for single inverter

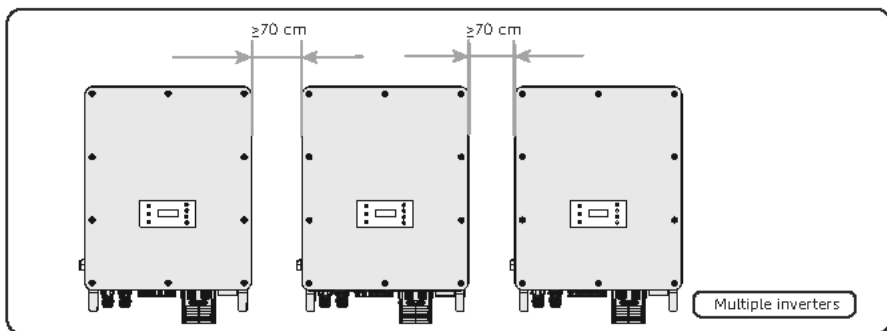

Figure 5-5 Clearance requirement for multiple inverters

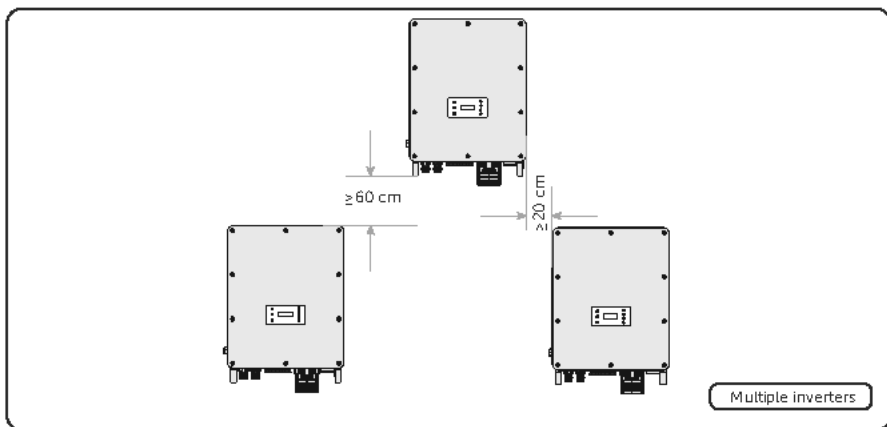



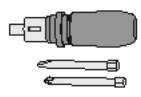
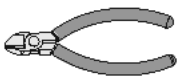

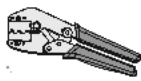
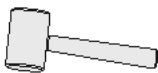
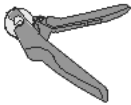

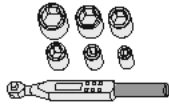



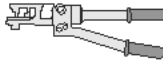

Figure 5-6 Clearance requirement for multiple inverters

## 5.2 Tools Requirement







Installation tools include but are not limited to the following recommended ones. If necessary, use other auxiliary tools on site.

 Hammer drill (drill bit: $\varnothing 15$ mm)	 Multimeter ( $\geq 1000$ V DC)	 Measuring tape	 Utility knife
 Marker	 Spirit level	 Torque screwdriver (Flat-head: M2 / M10) (Phillips head: M2.5 / M3 / M5 / M6)	 Diagonal pliers
 Wire stripper	 Crimping tool for RJ45	 Crimping tool for PV terminals	 Rubber mallet (hammer diameter < 34 mm)
 Crimping tool	 Crimping tool for ferrules	 Wire cutter	 Ladder (> 1.5m)
 Torque wrench (diameter: 10 mm / 17 mm)	 Heat gun	 Heat shrink tubing $\varnothing 13$ mm)	 Crane carrying capacity $\geq 150$ kg lifting height $\geq 2.1$ m
 Slings carrying capacity $\geq 150$ kg length $\geq 0.8$ m	 Hydraulic plier	 Safety gloves	 Safety boots



### 5.3 Additionally Required Materials

Table 5-2 Additionally required wires

No.	Required Material	Type	Conductor Cross-section
1	PV wire	 Dedicated PV wire with a voltage rating of 1000 V, a temperature resistance of 105 °C, a fire resistance grade of VW-1	6 mm <sup>2</sup>
2	Communication wire 1	 Network cable CAT5E	/
3	Communication wire 2	 Four-core signal cable	0.25 mm <sup>2</sup> -0.3 mm <sup>2</sup>
4	Grid and EPS wire	 Five-core copper cable (only for wall mounting) * If the inverter is connected with a battery cabinet, a crimped five-core copper Grid cable and a crimped four-core copper EPS cable is prefabricated in the cabinet	35 mm <sup>2</sup>
5	Additional PE wire	 Conventional yellow and green wire	25 mm <sup>2</sup>
6*	Battery power wire	 One-core copper cable	25 mm <sup>2</sup>

**Note:**

When the X3-AELIO series inverters are used in conjunction with the AELIO-B100 battery cabinet, the battery power wire is prefabricated in the cabinet, no additional battery power wire is required.

Table 5-3 Circuit breaker recommended for Grid connection

Model	50 kW	60 kW	49.9 kW	61 kW
Circuit breaker 	> 100A	> 125A	> 100A	> 125A

Table 5-4 Micro-breaker recommended for EPS connection



Model	50 kW	60 kW	49.9 kW	61 kW
Circuit breaker 	> 100A	> 125A	> 100A	> 125A

Table 5-5 RCD recommended

Model	50 kW	60 kW	49.9 kW	61 kW
RCD 	< 500 mA	< 600 mA	< 500 mA	< 600 mA

## 6 Unpacking and Inspection

---

### 6.1 Unpacking

- The inverter undergoes 100% testing and inspection before shipping from the manufacturing facility. However, transport damage may still occur. Before unpacking the inverter, please check the outer packing materials for damage, such as holes and cracks.
- Unpacking the inverter according to the following figure.

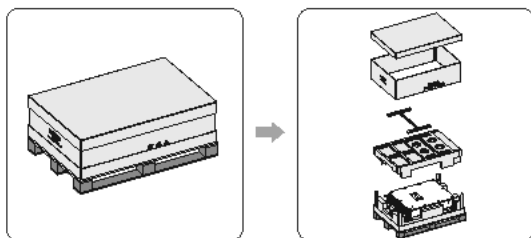
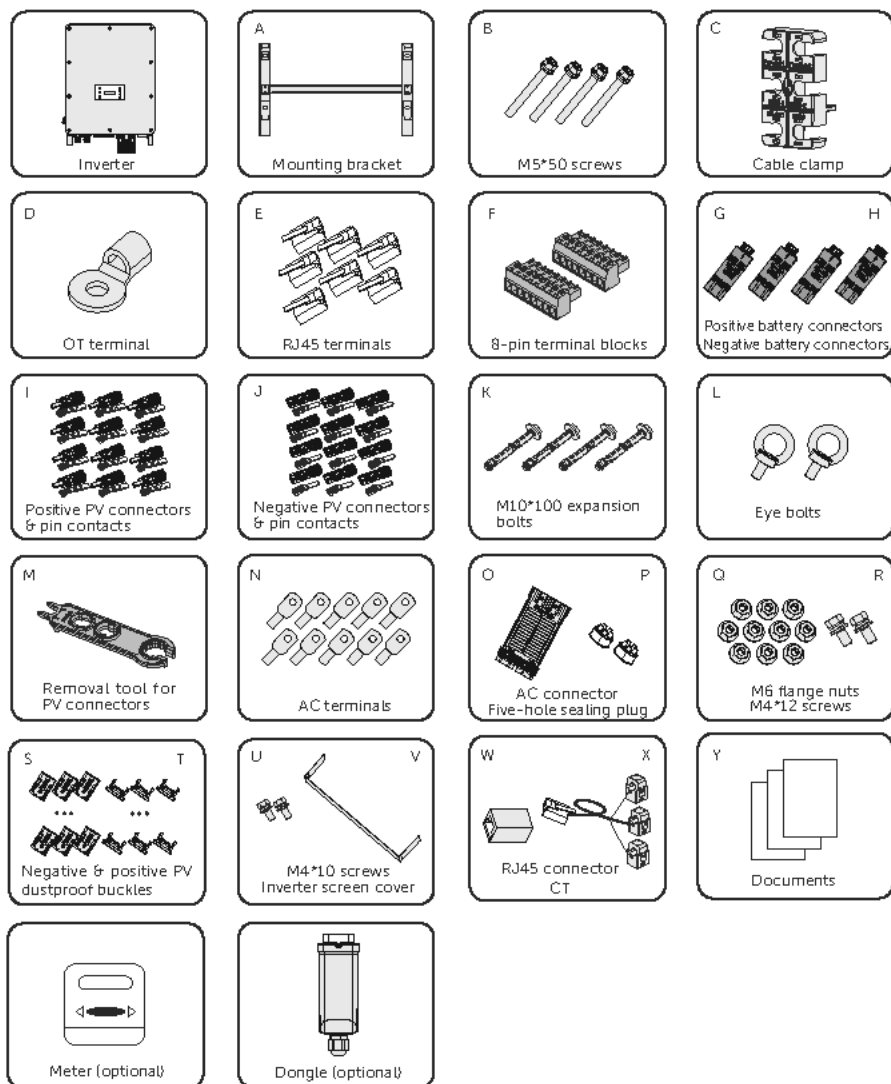

Figure 6-1 Unpacking the inverter

- Be careful when dealing with all package materials which may be reused for storage and relocation of the inverter in the future.
- Upon opening the package, check whether the appearance of the inverter is damaged or lack of accessories. If any damage is found or any parts are missing, contact your dealer immediately.

## 6.2 Scope of Delivery



\* Refer to the actual delivery for the optional accessories.

Table 6-6 Packing list

Item	Description	Quantity	Remark
/	Inverter	1 pc	

## Unpacking and Inspection

Item	Description	Quantity	Remark
A	Mounting bracket	1 pc	For wall mounting or battery cabinet mounting
B	M5*50 screw	4 pcs	For securing inverter on the bracket
C	Cable clamp	1 pc	For COM 1 connection
D	OT terminal	1 pc	For grounding
E	RJ45 terminal	7 pcs	For COM 1 and COM 2 connection
F	8-pin terminal block	2 pcs	For ripple control connection and DIO connection
G	Positive battery connector	2 pcs	For battery connection
H	Negative battery connector	2 pcs	For battery connection
I	Positive PV connector & pin contact	10 pairs for X3-AELIO-50K and X3-AELIO-49.9K 12 pairs for X3-AELIO-60K, X3-AELIO-61K and X3-AELIO-49.9K-P	For PV connection
J	Negative PV connector & pin contact	10 pairs for X3-AELIO-50K and X3-AELIO-49.9K 12 pairs for X3-AELIO-60K, X3-AELIO-61K and X3-AELIO-49.9K-P	For PV connection
K	M10*100 expansion bolt	4 pcs	For wall mounting bracket installation * When the inverter is installed on the cabinet, screws or bolts for securing the mounting bracket is provided in the accessory of a battery cabinet.
L	Eye bolt	2 pcs	For carrying the inverter
M	Removal tool for PV connectors	1 pc	For dismantling PV connectors from the inverter
N	AC terminal	10 pcs	For assembling the Grid and EPS cable
O	AC connector	1 pc	For Grid and EPS connection

Item	Description	Quantity	Remark
P	Five-hole sealing plug	2 pcs	For replacing the original AC connector sealing plug when the inverter is paired with the AELIO-B100 battery cabinet.
Q	M6 screw	10 pcs	For securing the Grid and EPS cable with AC terminals on the inverter
R	M4*12 screw	2 pcs	For securing AC connector
S	Negative PV dustproof buckle	12 pcs	For sealing negative PV terminals
T	Positive PV dustproof buckle	12 pcs	For sealing positive PV terminals
U	M4*10 screws	2 pcs	For securing the inverter screen cover
V	Inverter screen cover	1 pc	For covering the inverter screen
W	RJ45 connector	1 pc	For CT connection
X	CT	1 pc	
Y	Documents	/	
/	Meter (optional)	1 pc	
/	Dongle (optional)	1 pc	

**NOTICE!**

- The inverter shares the same accessories when it is installed on the wall or on the battery cabinet.
- Refer to the actual delivery for the optional accessories.

## 7 Mechanical Installation

### ⚠ WARNING!

- Only the qualified personnel can perform the mechanical installation following the local standards and requirements.
- Check the existing power cables or other piping in the wall to prevent electric shock or other damage.

### ⚠ CAUTION!

- Always be aware of the weight of the inverter. Personal injuries may result if the inverter is lifted improperly or dropped while being transported or mounted.
- Use insulated tools when installing the inverter. Personal protective equipment must be worn during installation and maintenance.

### NOTICE!

- Install the inverter at a maximum back tilt of 5 degrees and avoid forward tilted, side tilted, or upside down.

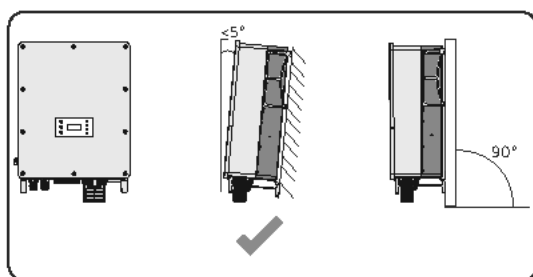

Figure 7-1 Correct installation

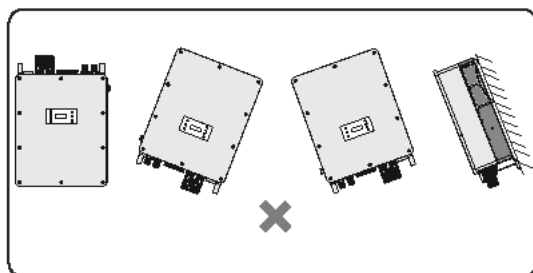

Figure 7-2 Incorrect installation

## 7.1 Dimensions for mounting

Check the dimensions of the wall mounting bracket before mounting and reserve sufficient space for heat dissipation and installation of the whole system.

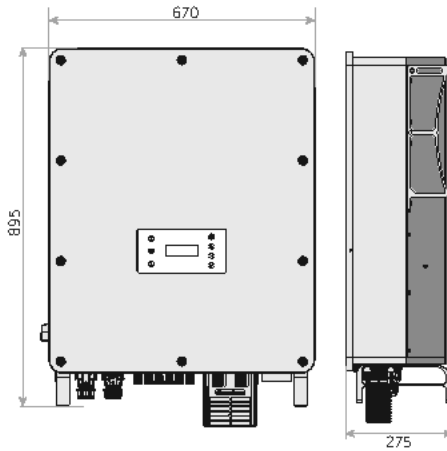

Figure 7-3 Dimensions 1 (Unit: mm)

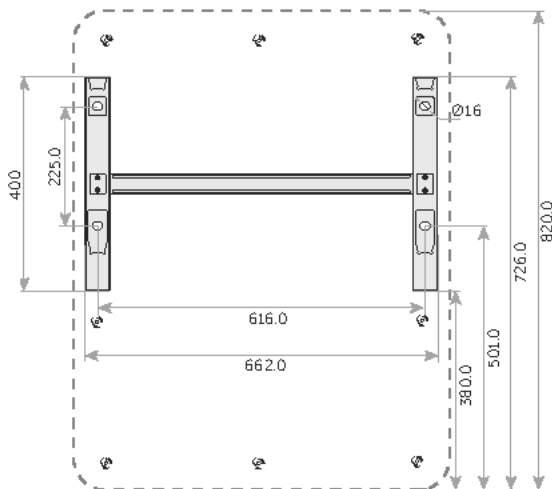

Figure 7-4 Dimensions 2 (Unit: mm)

## 7.2 Installation procedures

The device can choose to be installed on the wall or on the battery cabinet.

### 7.2.1 Wall mounting procedures

**Step 1:** Mark one of the position of drill holes at least 175 cm perpendicular to the ground. Align the mounting bracket horizontally on the wall and mark the rest positions of the drill holes in sequence.

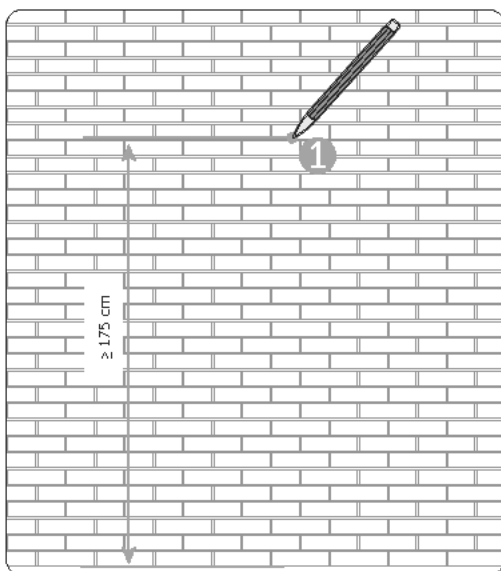

Figure 7-5 Marking the first hole

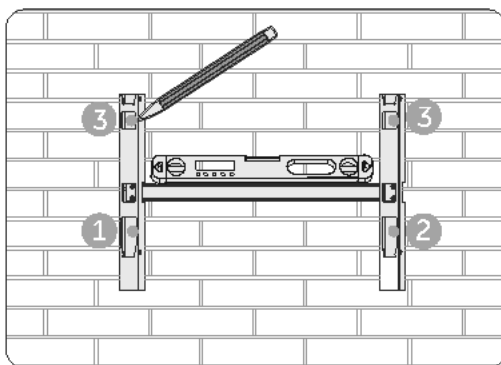

Figure 7-6 Marking the rest holes

## NOTICE!

- Take the height of the battery into account when mounting the mounting bracket.
- Observe the bubble of spirit level and adjust the mounting bracket until the bubble stays in the middle.

**Step 2:** Set the mounting bracket aside and drill holes with  $\varnothing 15$  mm drill bit. The depth of the holes should be deeper than 100 mm.

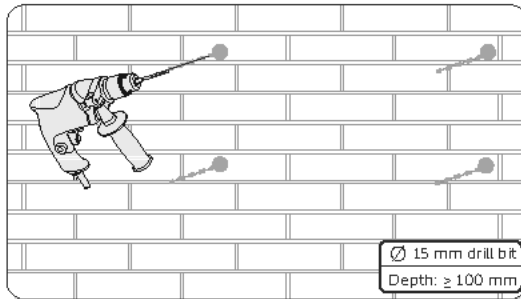

Figure 7-7 Drilling holes

**Step 3:** Attach the mounting bracket on the wall again. Knock the expansion screws through the bracket and into the holes and secure it to the wall by torque wrench. (Torque: 24 N·m)

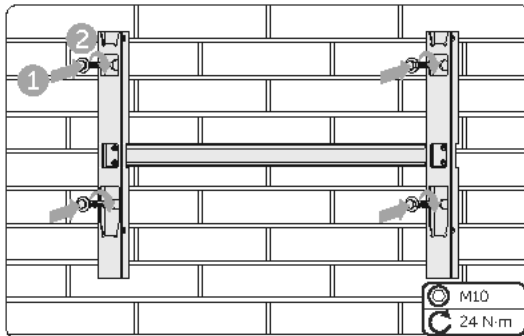

Figure 7-8 Securing the mounting bracket

**Step 4:** Open the anti-static bag and take out the machine.

## NOTICE!

- If the inverter is temporarily needed to be placed on the ground, use foam or other protective materials to prevent any damage to the inverter.

**Step 5:** Remove the carton, loosen and pull out the M10 screws on the sides of the

inverter with a flat-head screwdriver. Tighten the two eye bolts on the two sides of the inverter and tie them with a sling. Lift up the inverter with a crane and hang the device on the mounting bracket. The keyways of the inverter must be hooked into the buckles of the mounting bracket.

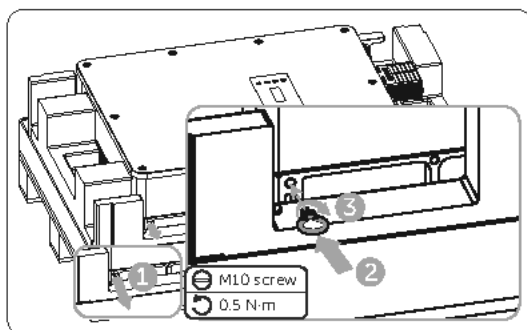

Figure 7-9 Installing the eye bolts

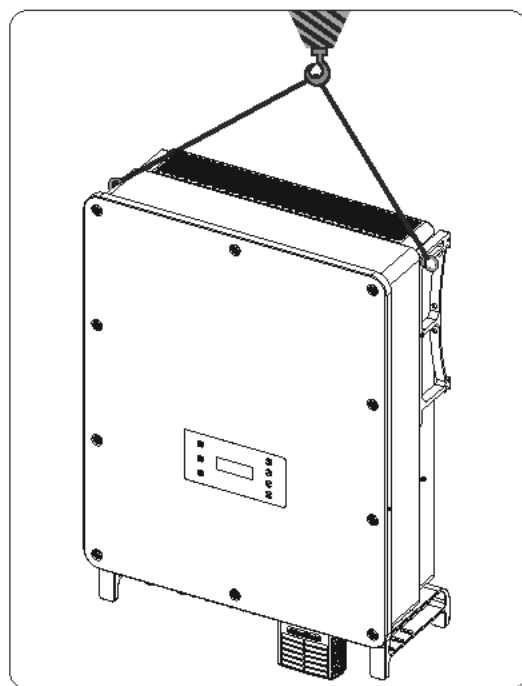

Figure 7-10 Hanging the inverter

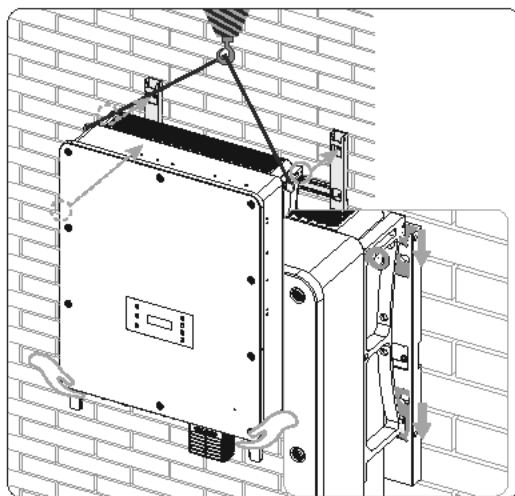

Figure 7-11 Hooking the inverter on the bracket

## NOTICE!

- When the inverter is lifted up from the carton or the inverter is close to the mounting bracket, use hands to adjust the inverter position to prevent any damage to the inverter.
- Ladders will be helpful for installers to stand in a proper position and adjust the inverter position.

**Step 6:** Remove the eye bolts when the inverter is hooked on the mounting bracket and tighten the M10 screws with a flat-head screwdriver.

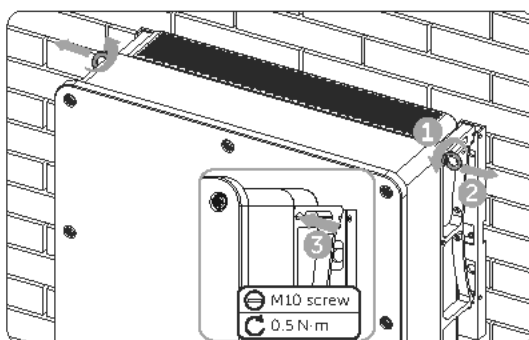

Figure 7-12 Removing the eye bolts

NOTICE!

- After removing the eye bolts from the inverter, keep them in a safe place. They are needed when the inverter is relocated or disassembled.

**Step 7:** Secure the inverter to the wall mounting bracket with M5\*50 screws. (Torque:  $2 \pm 0.2$  N·m)

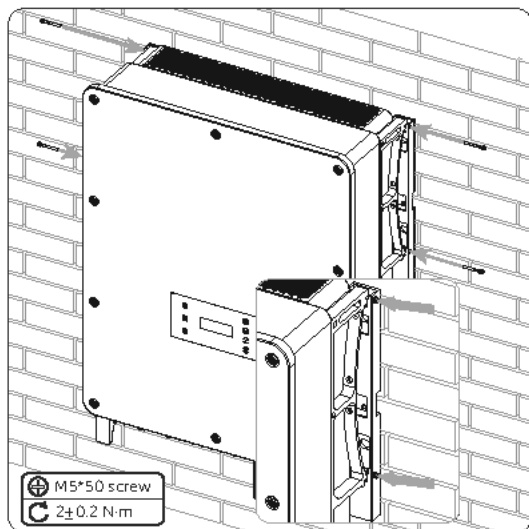

Figure 7-13 Securing the inverter

## 7.2.2 Cabinet installation procedures

**Step 1:** Confirm the four holes for the position of the mounting bracket on the battery cabinet.

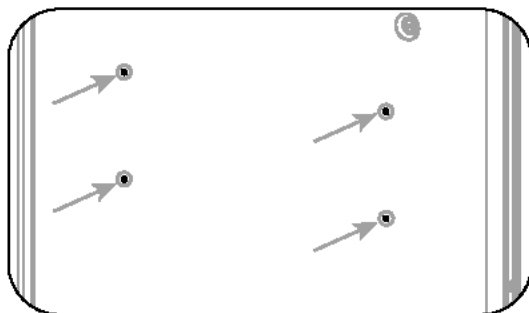

Figure 7-14 Confirming the position of the mounting bracket

- Step 2:** Take out the bracket from the carton. Attach the mounting bracket on the battery cabinet. Knock the expansion screws into the holes and secure it to the cabinet by torque wrench. (Torque: 24 N·m)

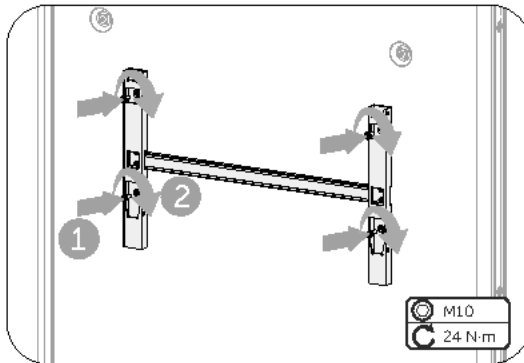

Figure 7-15 Securing the mounting bracket

- Step 3:** Open the anti-static bag and take out the machine.

**NOTICE!**

- If the inverter is temporarily needed to be placed on the ground, use foam or other protective materials to prevent any damage to the inverter.

- Step 4:** Remove the carton, loosen and pull out the M10 screws on the sides of the inverter with a flat-head screwdriver. Tighten the two eye bolts on the two sides of the inverter and tie them with a sling. Lift up the inverter with a crane and hang the device on the mounting bracket. The keyways of the inverter must be hooked into the buckles of the mounting bracket.

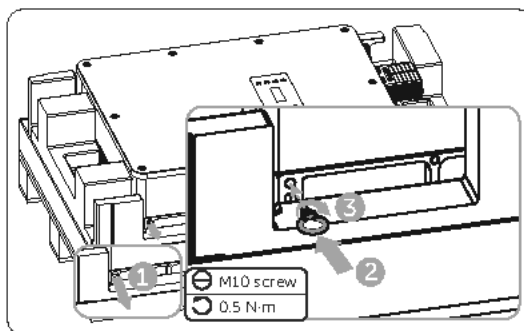

Figure 7-16 Installing the eye bolts

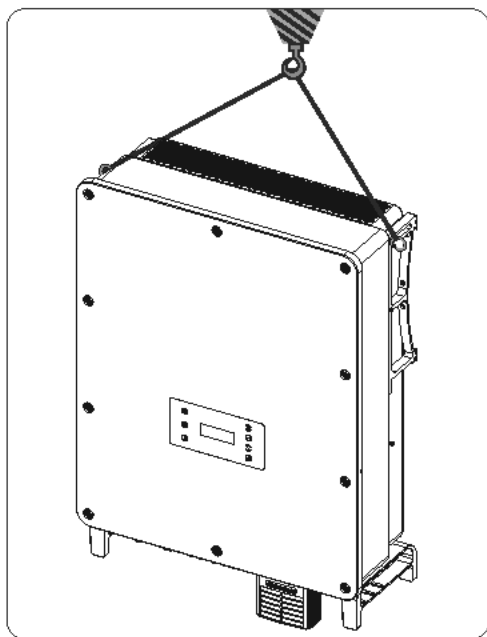

Figure 7-17 Hanging the inverter

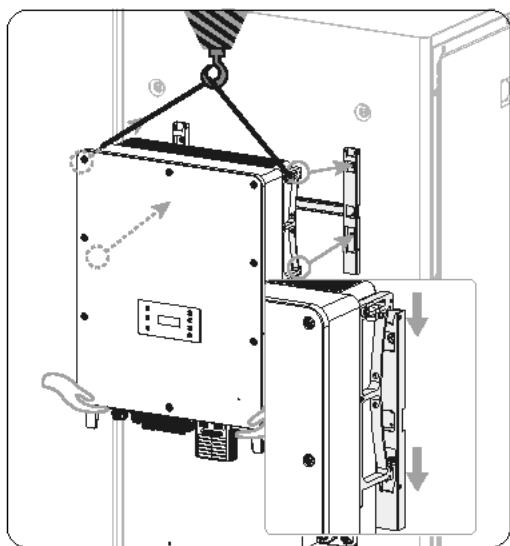

Figure 7-18 Hooking the inverter on the bracket

## NOTICE!

- When the inverter is lifted up from the carton or the inverter is close to the mounting bracket, use hands to adjust the inverter position to prevent any damage to the inverter.
- Ladders will be helpful for installers to stand in a proper position and adjust the inverter position.

**Step 5:** Remove the eye bolts when the inverter is hooked on the mounting bracket and tighten the M10 screws with a flat-head screwdriver.

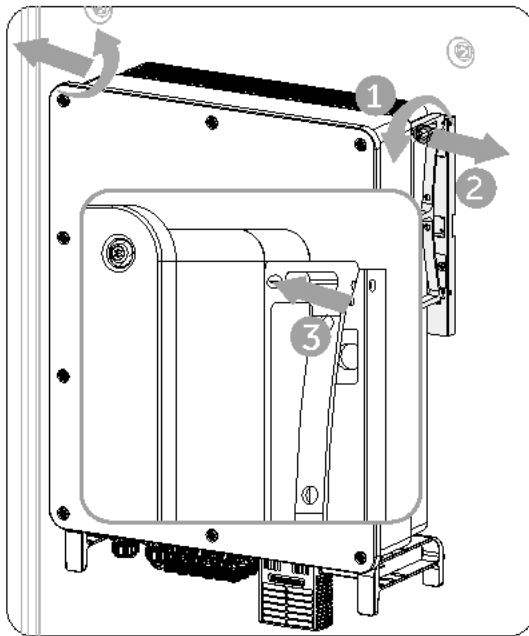

Figure 7-19 Removing the eye bolts

## NOTICE!

- After removing the eye bolts from the inverter, keep them in a safe place. They are needed when the inverter is relocated or disassembled.

**Step 6:** Secure the inverter to the mounting bracket with M5\*50 screws. (Torque:  $2 \pm 0.2$  N·m)

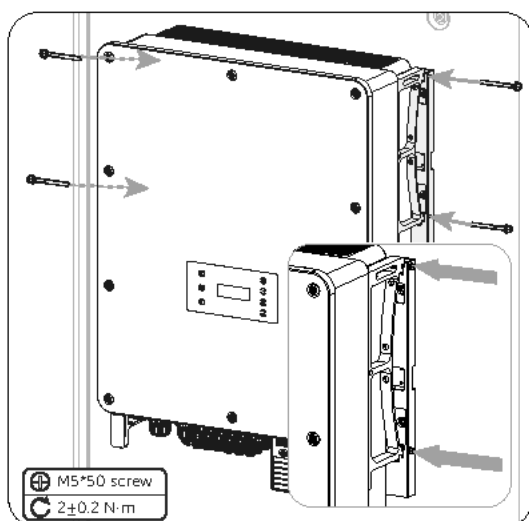

Figure 7-20 Securing the inverter

### 7.2.3 Inverter screen cover installation

After the inverter is well installed on the wall or on the cabinet, all cables are wired on the inverter, the process of powering on and powering off is checked and all necessary settings are set on the inverter LCD screen, the inverter screen cover should be installed. Here below the inverter installed on the cabinet is taken for an example. Wall-mounting inverter shares the the same screen cover installation method.

**Step 1:** Put the inverter screen cover on the inverter and secure the cover on the two sides of the inverter with M4\*10 screws (Torque:  $1.5\pm 0.3$  N·m).

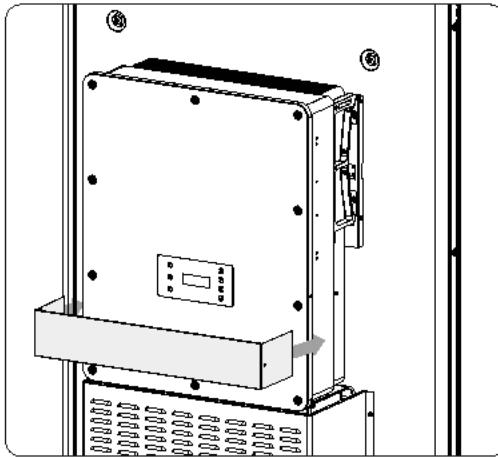

Figure 7-21 Putting the screen cover on the inverter

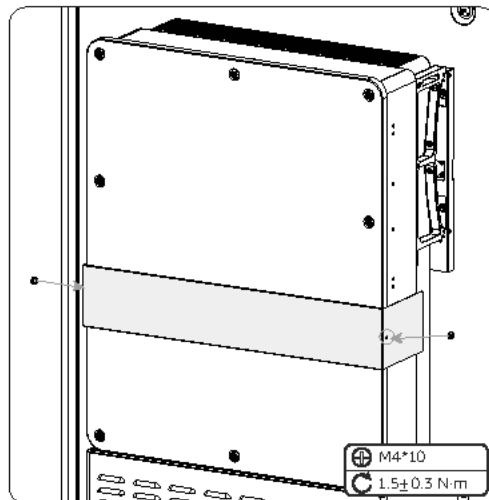

Figure 7-22 Securing the cover with the inverter

**Step 2:** Here is the well installed inverter screen cover.

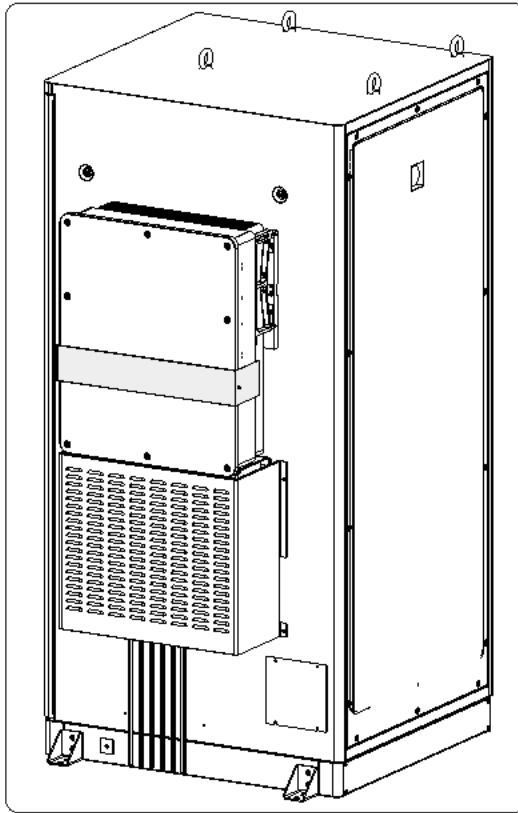

Figure 7-23 Well installed screen cover

**NOTICE!**

- Please refer to the battery documentation for detailed wiring procedures for cables from the inverter on the battery side.

## 8 Electrical Connection

### ⚠ DANGER!

- Before electrical connection, make sure the DC switches and AC breakers are disconnected. Otherwise, electrical shock may be caused by high voltage, resulting in serious personal injury or death.

### ⚠ WARNING!

- Only the qualified personnel can perform the electrical connection following the local standards and requirements.
- Follow this manual or other related document to wire connection. The inverter damage caused by incorrect cabling is not in the scope of warranty.
- Use insulated tools and wear personal protective equipment throughout the electrical connection process.

### NOTICE!

- When the inverter is wall-mounted or is installed on a battery cabinet, the wiring procedure and electrical connection method on the inverter are the same.

### 8.1 Terminals of Inverter

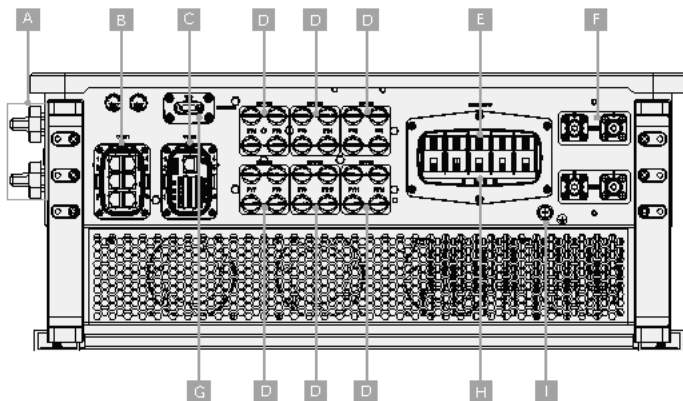



Figure 8-1 Terminals of Inverter

Table 8-1 Description of terminals

Item	Description
A	DC switch (including DC switch 1 and DC switch 2)
B	COM 1 communication terminal (including Parallel-1, Parallel-2, BMS-1, BMS-2, RS485, DRM)
C	COM 2 communication terminal (including Ripple control, DIO, Meter/CT)
D	PV connection terminal (PV1~PV5 terminals for X3-AELIO-50K and X3-AELIO-49.9K; PV1~PV6 terminals for X3-AELIO-60K, X3-AELIO-61K and X3-AELIO-49.9K-P)
E	EPS connection terminal
F	Battery connection terminal (including BAT 1 and BAT 2)
G	Dongle terminal
H	Grid connection terminal
I	Ground connection point

## 8.2 PE Connection

All non-current carrying metal parts of the equipment and other enclosures in the PV system must be grounded reliably. The PE point at the AC output terminal is used only as a PE equipotential point, not a substitute for the PE point on the enclosure. The connection point has been labeled with the following label:  We recommend that the inverter is earthed to a nearby ground point.

### CAUTION!

- In compliance with IEC62109-2, X3-AELIO series inverter has the grounding detection function which is used to check whether the inverter is properly grounded before it starts. If the inverter is not connected with earth, the inverter will turn on a red light and report **Earth Relay Fault**.

## PE connection procedures

**Step 1:** Strip the insulation of the conductor with a wire stripper.

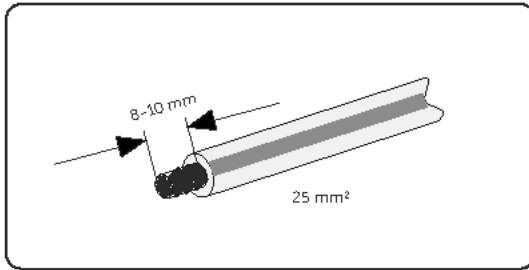

Figure 8-2 Stripping the PE cable

**Step 2:** Pull the  $\varnothing 13$  mm heat-shrink tubing over the PE cable and insert the stripped section into the OT terminal.

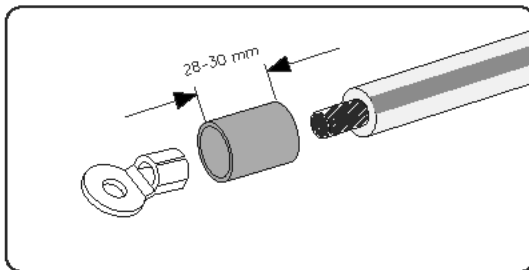

Figure 8-3 Installing the tubing and OT terminal

**Step 3:** Crimp it with a crimping tool, pull the heat-shrink tubing over the stripped section of the OT terminal, and use a heat gun to shrink it so that it can be firmly contacted with the terminal.

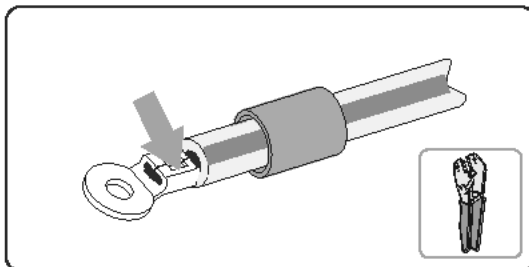

Figure 8-4 Crimping the cable

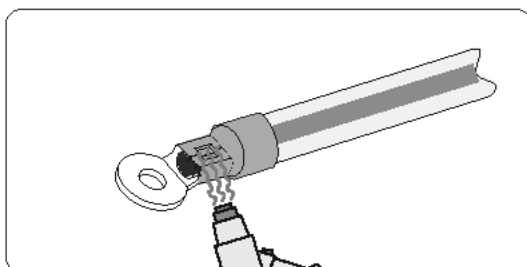

Figure 8-5 shrinking the tubing

**Step 4:** Loosen the PE screw on the inverter with a cross screwdriver.

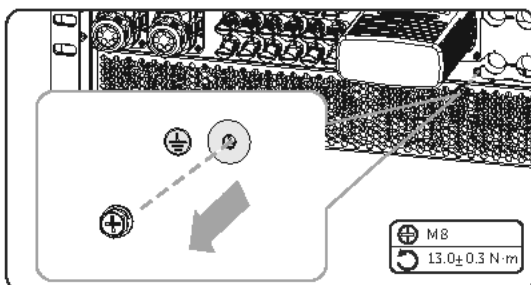

Figure 8-6 Uninstalling the screw

**Step 5:** Connect the assembled PE cable to the inverter and secure it with the original screw. (Torque:  $13.0 \pm 0.3$  N·m)

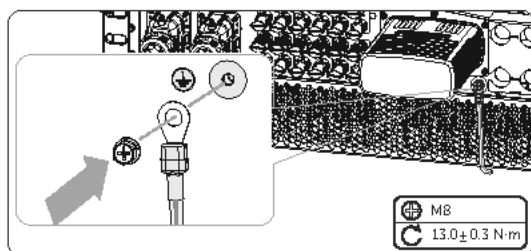

Figure 8-7 Securing the PE cable

## 8.3 AC Connection

### NOTICE!

- Before connecting the inverter to the grid, approval must be received by local utility as required by national and state interconnection regulations.

The inverter has an EPS function. When the grid is connected, the inverter outputs go through the Grid terminal, and when the grid is disconnected, the inverter outputs go through the EPS terminal.

### Requirements for AC connection

- Grid voltage requirement
  - » The grid voltage must be within the permissible range. The inverter is suitable for rated voltage 400V/230V, 380/220V, frequency 50/60Hz. Other technical requests should comply with the requirement of the local public grid.
- RCD requirement
  - » The inverter does not require an external residual-current device when operating. If an external RCD is required by local regulations, it is recommended to use a Type-A RCD with the value of 300 mA. When required by local regulations, the use of an RCD type B is permitted.
- AC breaker requirement
  - » An AC breaker that matches the power of the inverter must be connected between the inverter output and the power grid, and each inverter must be equipped with an independent breaker or other load disconnection unit to ensure the safe disconnection from the grid. Refer to "5.3 Additionally Required Materials" for specific data of AC breaker of Grid and EPS.
- Load requirement
  - » It is prohibited to connect any load between inverter and AC switch that directly connects to the inverter.
- EPS load requirement
  - » Do not connect sensitive precision instruments or medical equipment to the EPS terminal.
  - » Ensure that the EPS load rated power is within the EPS rated output power range. Otherwise, the inverter will report an **EPS Overload Fault** warning. When **EPS Overload Fault** occurs, turn off some loads to make sure it is within the EPS rated output power range, and the inverter will return to normal after **ESC** key on the LCD screen pressed.
  - » For inductive load such as fridge, air conditioner, washing machine, etc., ensure that the start power does not exceed the EPS peak power.

Table 8-2 EPS load information

Type of load	Equipment	Start power
Resistive load	Lamp	Equal to rated power
	Fan	Equal to rated power
	Hairdryer	Equal to rated power
Inductive load	Fridge	3-5 times rated power
	Air conditioner	3-6 times rated power
	Washing machine	3-5 times rated power
	Microwave oven	3-5 times rated power

\* Please refer to the nominal current of the equipment for the actual start current.

### Wiring procedures

#### NOTICE!

- When the inverter is connected to a battery cabinet, Grid and EPS cable crimped with AC connectors are prepared in the accessory of the cabinet and installers do not need to make cables.

**Step 1:** Prepare a Grid cable (five-core copper wire) and a EPS cable (five-core copper wire) and strip the insulation of the Grid and EPS cable as below. Remove the cable padding inside the insulation.

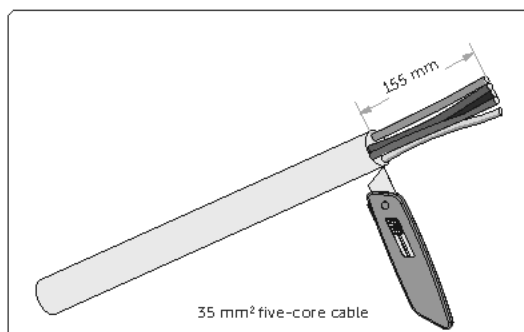

Figure 8-8 Stripping the Grid cable

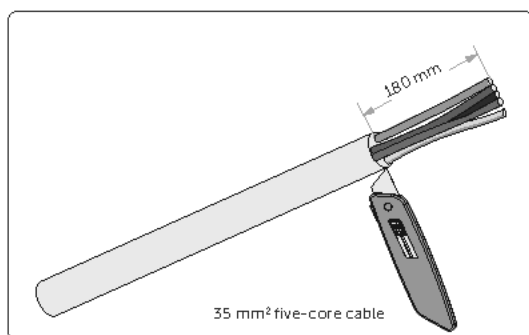

Figure 8-9 Stripping the EPS cable

**Step 2:** Trim L1, L2, L3, N and grounding cable of the Grid and EPS cable. Keep each cable at a length in accordance with the table below.

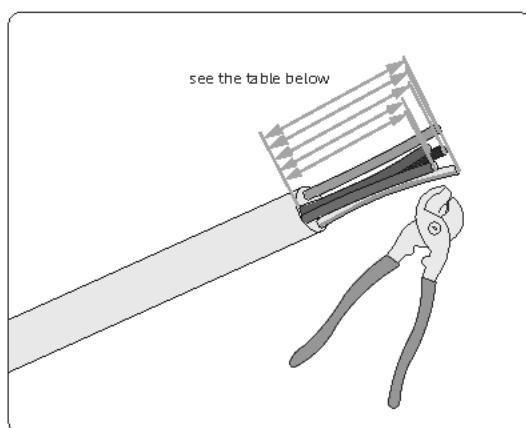

Figure 8-10 Trimming cables of the Grid and EPS cable

Table 8-3 Length of each cable of the Grid and EPS cable

Type of cable	Number of each cable	Length of cable (mm)
Grid cable	Grid_N	135
	Grid_L1	135
	Grid_L2	145
	Grid_L3	145
	Grid_PE	155
EPS cable	EPS_N	180

EPS cable	EPS_L1	170
	EPS_L2	170
	EPS_L3	160
	EPS_PE	160

**Step 3:** Strip the insulation of L1, L2, L3, N and grounding cable of the Grid and EPS cable at a length of 16 mm.

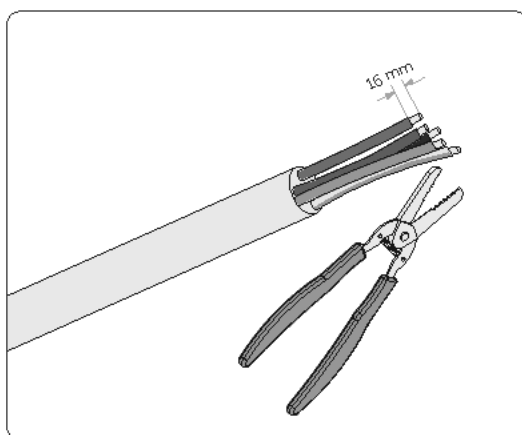

Figure 8-11 Stripping cables

**Step 4:** Loosen the swivel nuts of the AC connector to disassemble it as below.

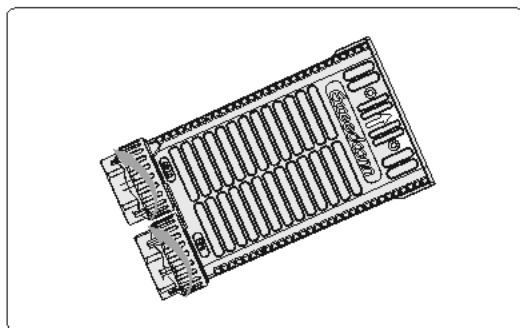

Figure 8-12 Disassembling the AC connector

**Step 5:** Disassemble the AC connector. Deal with the sealing plugs with the diameter of Grid and EPS cable used. Installers remove seals from a smaller to a larger one in accordance with the diameter of cables selected. If the diameter of the cable used is over 33 mm, remove the smallest seal No.1. If the diameter of the cable is 29~33 mm, cut the membrane inside the seal No.1 and thread cable through it.

Table 8-4 Selection of AC connector seals

Seal No.	Diameter of the seal bore (mm)	Diameter of cable selected (mm)
1	34	29~33
2	39	33~38
3	44	38~43
4	49	43~48

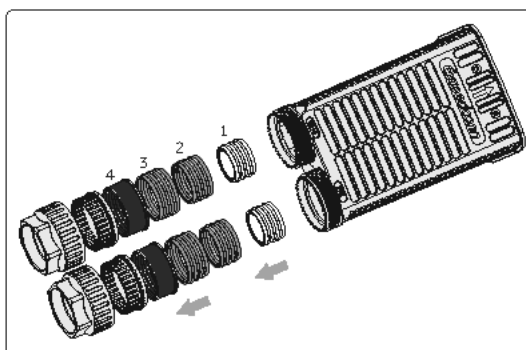

Figure 8-13 Disassembling the swivel nuts

## NOTICE!

- When connecting the inverter to the AELIO-B100 battery cabinet, replace the original sealing plugs with the five-hole sealing plugs.

**Step 6:** Thread the stripped Grid and EPS cable through the AC connector.

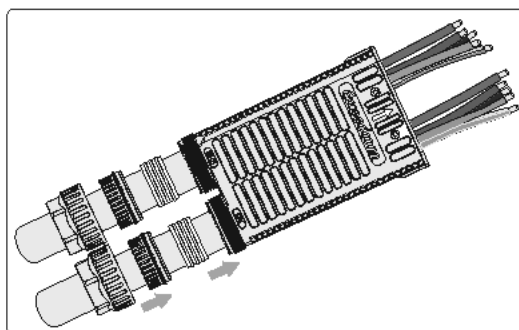

Figure 8-14 Threading cables through the AC connector

- Step 7:** Cut the  $\varnothing 13$  mm heat shrink tubings at the length of 25-30 mm. Thread L1, L2, L3, N and grounding cable of Grid and EPS cable through the heat shrink tubings and insert AC terminals into each cable.

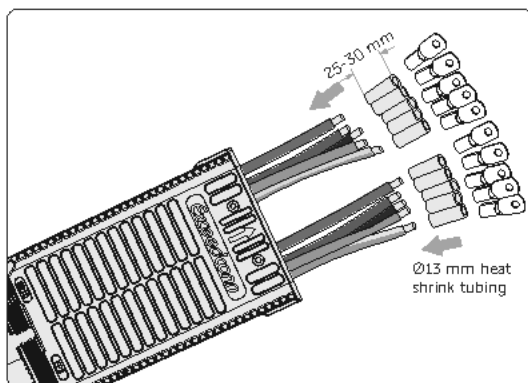

Figure 8-15 Assembling tubings and AC terminals

- Step 8:** Crimp the AC terminals. Pull the tubings to cover the joints of the stripped cable and AC terminal and then use a heat gun to shrink the tubings.

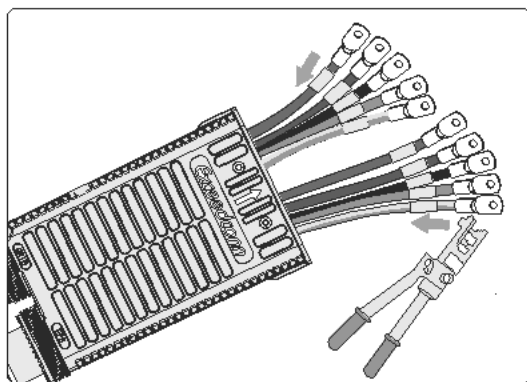

Figure 8-16 Crimping AC terminals

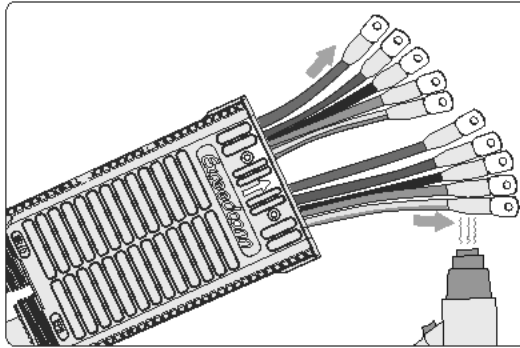

Figure 8-17 Shrinking the tubings

- Step 9:** Secure the L1, L2, L3, N and grounding conductors of the assembled Grid cable with M6 screws. (Torque:  $5.0 \pm 1$  N·m) Make sure the conductors are correctly assigned and firmly seated in the terminals.

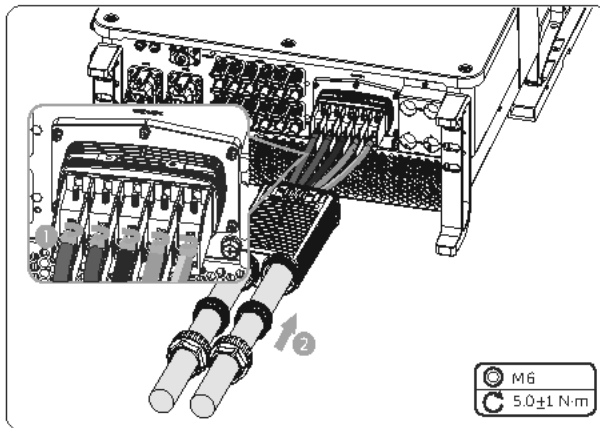

Figure 8-18 Connecting the Grid cable

- Step 10:** Secure the L1, L2, L3, N and grounding conductors of the assembled EPS cable with M6 screws. (Torque:  $5.0 \pm 1$  N·m) Make sure the conductors are correctly assigned and firmly seated in the terminals. Connect the enclosure of the AC connector to the inverter, insert the waterproof seals into the AC connector, and tighten the swivel nuts of the connector.

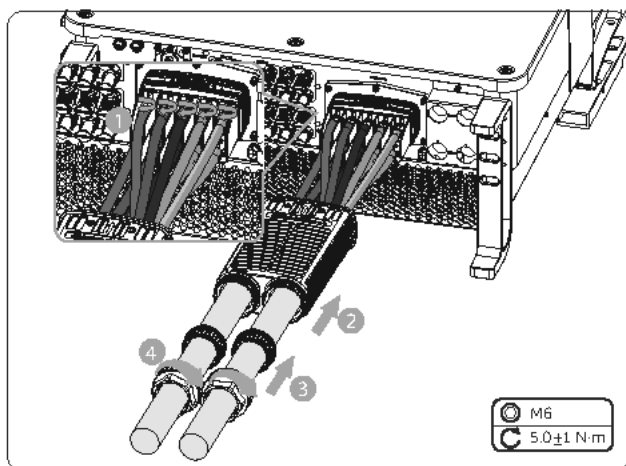

Figure 8-19 Connecting the EPS cable

**Step 11:** Connect the assembled AC connector to the AC port of the inverter, tighten the two M4\*12 screws on the AC connector enclosure (Torque:  $1.5 \pm 0.3$  N·m) and tighten the swivel nuts clockwise.

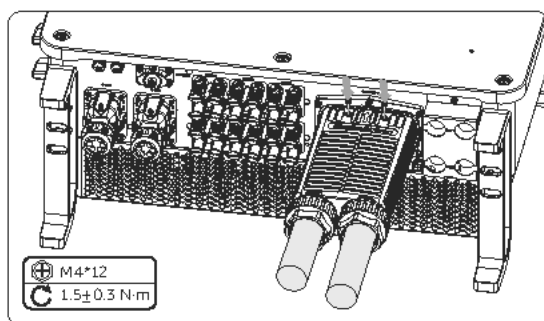

Figure 8-20 Securing the AC connector on the inverter

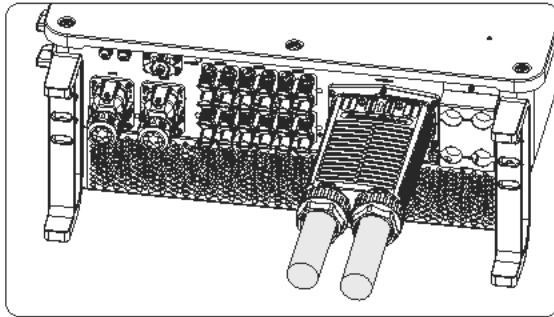

Figure 8-21 Well connected aAC connector

**⚠ DANGER!**

- Before powering on the inverter, make sure the AC connector has been installed correctly on the Grid and EPS terminal even if the EPS terminal is not wired. Otherwise, electrical shock may be caused by high voltage, resulting in serious personal injury or death.

**⚠ WARNING!**

- Reinstall AC terminal caps immediately after removing the connectors from terminals.

## 8.4 PV Connection

**⚠ DANGER!**

- High DC voltage will be generated by PV modules when exposed to sunlight. Death or lethal injuries will occur due to electric shock.
- Make sure the DC switch and AC breaker are disconnected from the inverter before connection.
- Make sure that the PV module output is well insulated to ground.

**⚠ CAUTION!**

- Power is fed from more than one source and more than one live circuit.

### Requirements for PV connection

- Open circuit voltage and working voltage
  - » The open circuit voltage of the module array should be less than the

maximum PV input voltage (1000 V) of the inverter. Otherwise the inverter may be damaged.

- » The working voltage should be within the MPPT voltage range (160-950 V). Otherwise, the inverter will prompt **PV Volt Fault**. Consider the impact of low temperature on the voltage of the photovoltaic panels, as lower temperatures tend to result in higher voltages.
- » The working voltage should be within the full load MPPT range (320-800V). Otherwise, the inverter will prompt derating protection.
- PV module
  - » The PV modules within the same MPPT channel are of the same brand. Additionally, the strings within the same channel should have identical quantities, and be aligned and tilted identically.
  - » The positive or negative pole of the PV modules is not grounded.
  - » The positive cables of the PV modules must be connected with positive DC connectors.
  - » The negative cables of the PV modules must be connected with negative DC connectors.

### Wiring procedures

**Step 1:** Strip approx. 7 mm of the cable insulation.

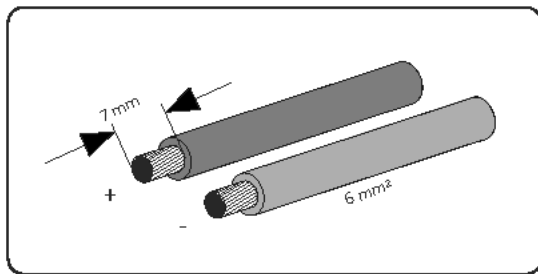

Figure 8-22 Striping the PV cable

**Step 2:** Insert the stripped cable into the PV pin contact. Ensure that the stripped cable and the PV pin contact are of the same polarity. Crimp it with a crimping tool for PV terminal.

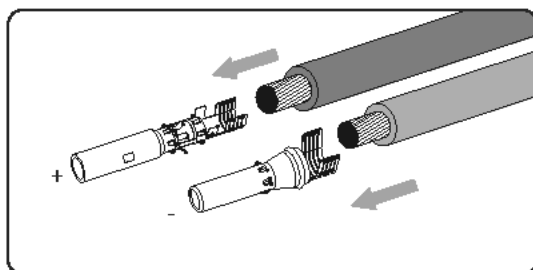

Figure 8-23 Inserting the PV pin contact

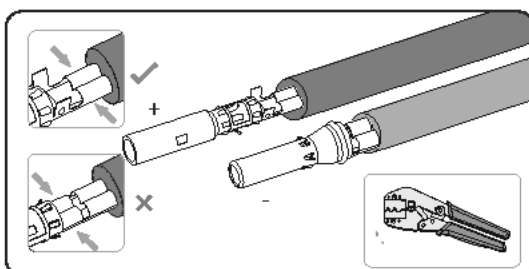

Figure 8-24 Crimping the terminal

 **WARNING!**

- To mitigate the risk of fire, it is crucial to utilize a dedicated crimping tool specifically designed for PV installations to ensure secure and reliable connections.

**Step 3:** Thread the PV cable through the swivel nut and insert the cable into the PV connector until a “Click” is heard. Gently pull the cable backward to ensure a firm connection. Tighten the swivel nut clockwise. Verify that the PV connectors have the correct polarity before connection.

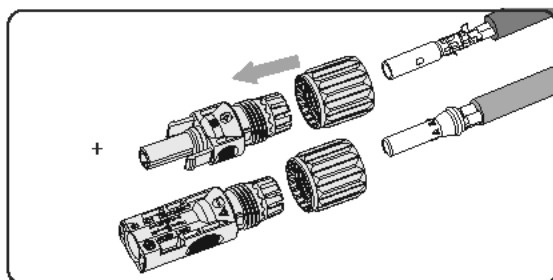

Figure 8-25 Threading the PV cable

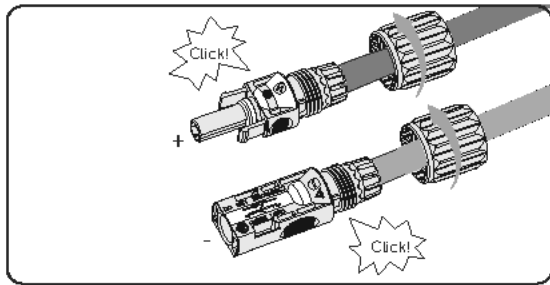

Figure 8-26 Securing the PV cable

**Step 4:** Use a multimeter to measure the positive and negative voltage of the assembled PV connectors. Make sure the open circuit voltage does not exceed the input limit of 1000 V.

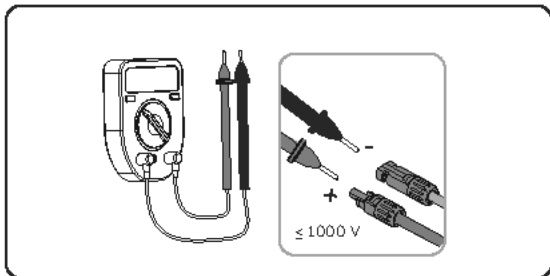

Figure 8-27 Measuring the voltage of PV connectors

**NOTICE!**

- If the voltage reading is negative, it indicates an incorrect DC input polarity. Please check if the wiring connections on the multimeter is correct or PV connectors are not mistakenly connected.

**Step 5:** Remove the PV terminal caps and connect the assembled PV connectors to corresponding terminals until there is an audible "Click". The PV+ on the string side must be connected to the PV+ on the inverter side, and the PV- on the string side must be connected to the PV- on the inverter side.

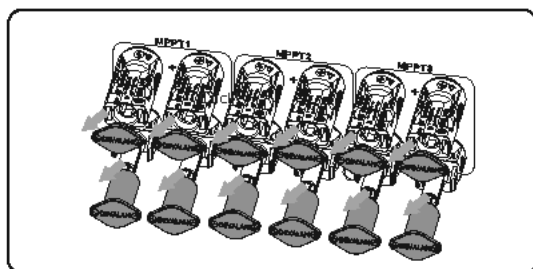

Figure 8-28 Connecting the PV cable

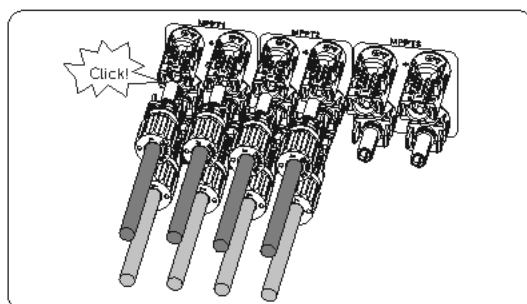

Figure 8-29 Connecting assembled PV cables to the inverter

- Step 6:** Seal the unused positive and negative PV terminals with corresponding PV dustproof buckles. Reinstall them immediately after removing the connectors from terminals.

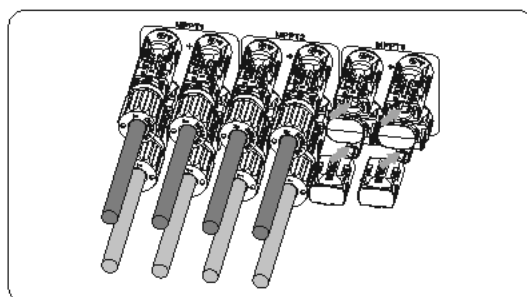

Figure 8-30 Installing PV dustproof buckles

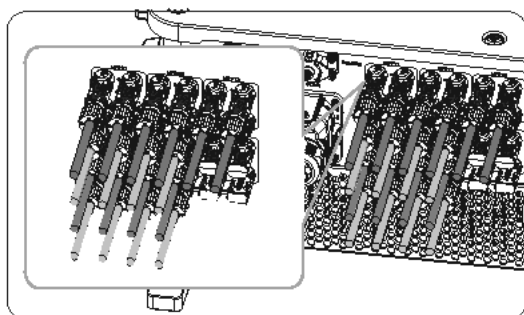

Figure 8-31 Well connected PV cables and dustproof buckles

## 8.5 Battery Power Cable Connection



- Make sure the breaker of battery is in OFF position.
- Always ensure correct polarity. Never reverse the polarity of the battery cables as this will result in inverter damage.

### Requirments for battery connection

- Required battery
  - » Lithium-ion battery
  - » The inverter is equipped with two independent battery terminals, allowing for connection to two separate battery towers. Max charge and discharge current is 160 (80\*2) A for each BAT terminal.
  - » Make sure the input voltage of each BAT terminal is higher than minimum voltage 180 V and lower than maximum input voltage 820 V.
- Micro circuit breaker (MCB)
  - » If local regulations mandate the use of a DC MCB between the battery and the inverter, install a non-polar DC MCB.
  - » Nominal voltage of DC MCB should be larger than maximum voltage of battery.
  - » See the documentation of battery for the current.
- Battery configuration information
  - » A battery cluster consists of one TBMS-R15 and a number of TB-HR140 battery modules. 7-14 battery modules can be included in one battery cluster.
  - » For AELIO-B100 and AELIO-B200, the total capacity connected to a X3-AELIO-50K, X3-AELIO-60K, X3-AELIO-49.9K and X3-AELIO-61K inverter can be 100 kWh and 200 kWh respectively.

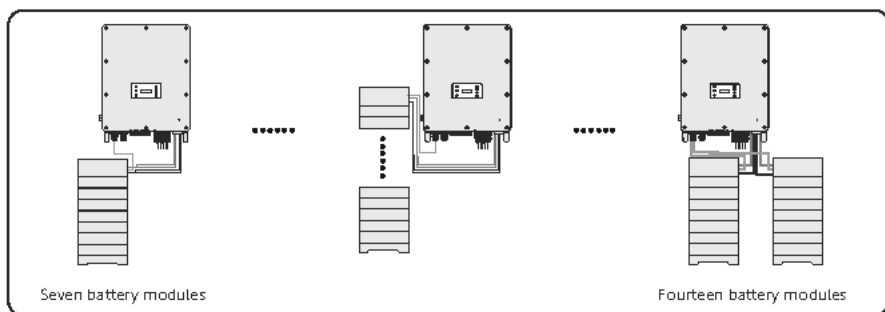

Figure 8-32 Inverter with split battery modules

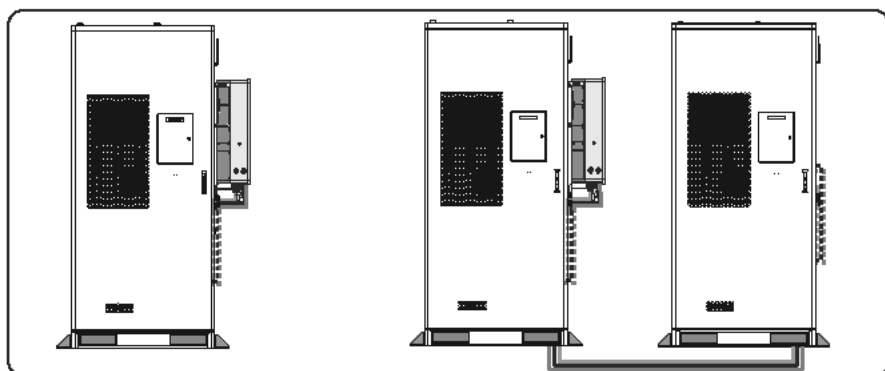

Figure 8-33 Inverter with battery cabinet(s)

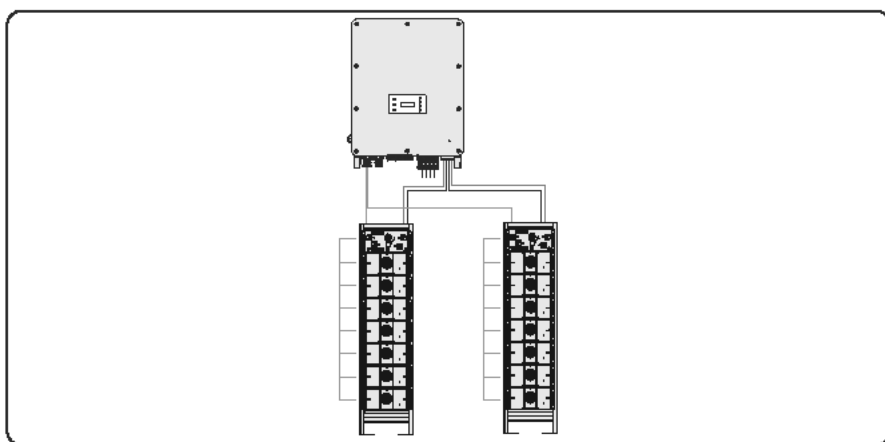

Figure 8-34 Inverter with battery bracket

## Wiring procedures

**Step 1:** Disassemble the battery connectors.

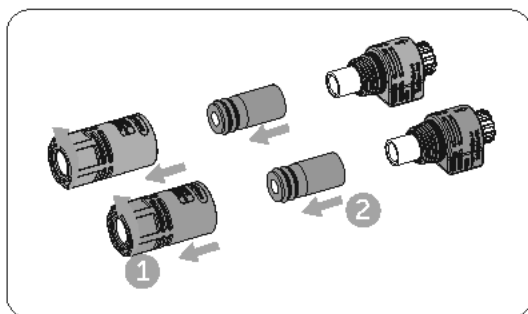

Figure 8-35 Disassembling battery connectors

**Step 2:** Thread the battery power cable through the swivel nut and then the cable support sleeve. Strip  $15 \pm 1$  mm insulation off.

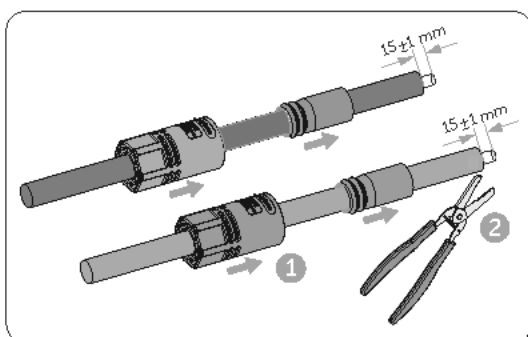

Figure 8-36 Stripping the battery power cable

**Step 3:** Insert the stripped cable into the connector enclosure. Ensure that the stripped cable and the enclosure are of the same polarity. Crimp it with a hydraulic plier at  $7.2 \pm 0.2$  mm and ensure that the exposed core of the cable is no more than 1 mm.

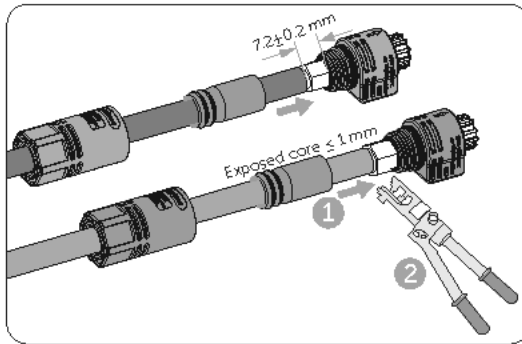

Figure 8-37 Crimping the terminal

**NOTICE!**

- Before the battery power cables are stripped, please ensure that the exposed core of cables should be less than 1 mm when the battery connectors are crimped.

**Step 4:** Pull the cable support sleeve over the crimped battery connector enclosure and then the swivel nut to the enclosure. Tighten the swivel nut.

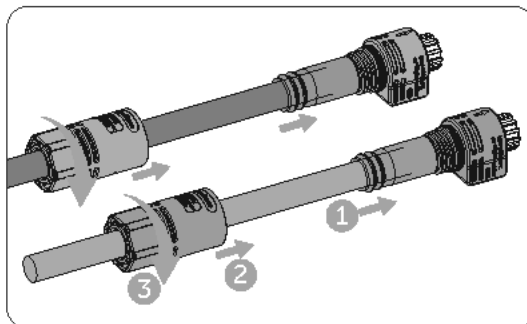

Figure 8-38 Tightening the battery connector

- Step 5:** Loosen the screws on the battery protective cover and remove the cover. Pull out the battery caps.

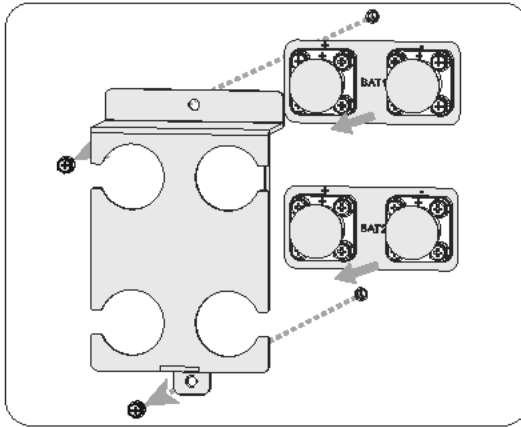

Figure 8-39 Removing the battery protective cover

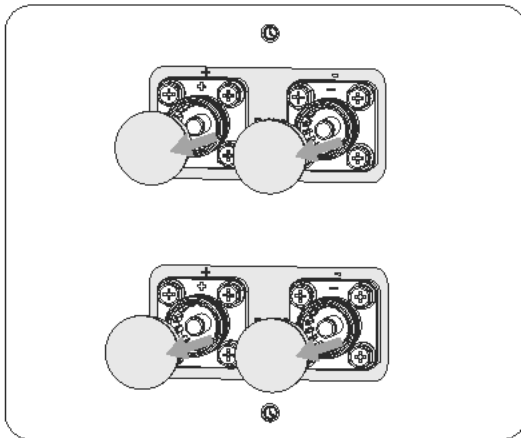

Figure 8-40 Removing battery caps

- Step 6:** Connect the assembled battery connectors to corresponding terminals until there is an audible "Click". The BAT+ on the string side must be connected to the BAT+ on the inverter side, and the BAT- on the string side must be connected to the BAT- on the inverter side. Gently pull the cable backward to ensure firm connection.

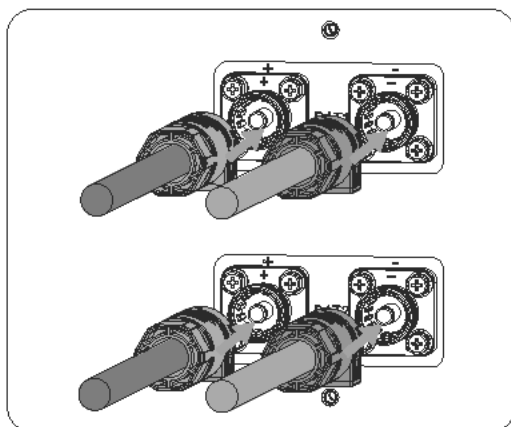

Figure 8-41 Connecting assembled battery cables

**Step 7:** After the battery cables are connected, install the battery protective cover and secure the cover on the inverter with screws.

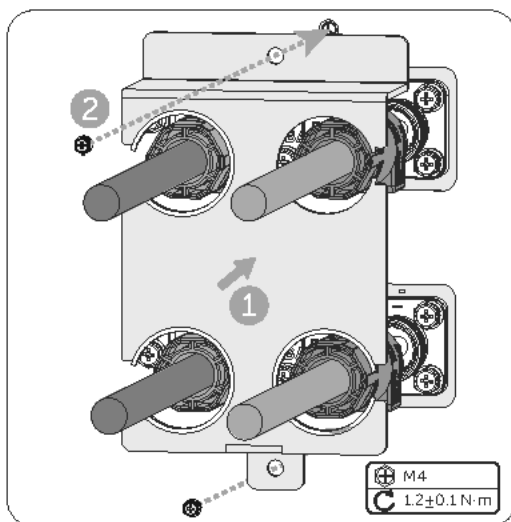

Figure 8-42 Installing the battery protective cover

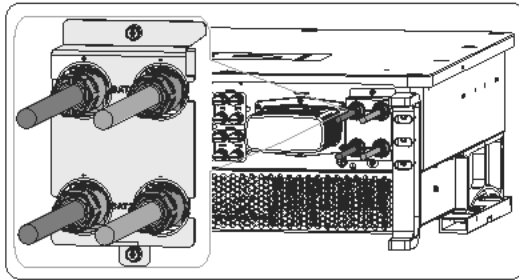

Figure 8-43 Well connected battery cables

**⚠ WARNING!**

- Seal the unused battery terminals with original terminal caps.
- Keep the terminal caps in a safe place if battery cables are connected to the inverter.
- Reinstall it immediately after removing the connectors from terminals.

**NOTICE!**

- Please refer to the battery document for specific wiring procedures on the battery side.

## 8.6 COM 1 Communication Connection

### 8.6.1 Pin Assignment of COM 1 Terminal

The COM 1 terminal is used for parallel connection via Parallel-1 and Parallel-2 communication terminal, battery communication via BMS-1 and BMS-2 terminal, external equipment communication via RS485 and DRM function.

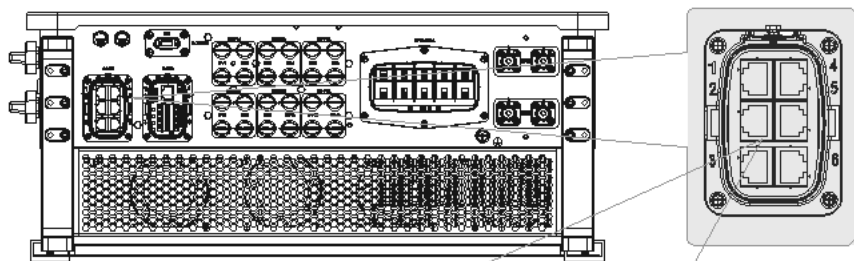

#### PARALLEL 1

- 1: PARALLEL\_485A
- 2: PARALLEL\_485B
- 3: DATA\_BUS
- 4: PARALLEL\_CANH
- 5: PARALLEL\_CANL
- 6: GND\_COM
- 7: PARALLEL\_SYNC1
- 8: PARALLEL\_SYNC2

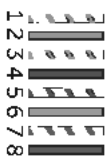

#### PARALLEL 2

- 1: PARALLEL\_485A
- 2: PARALLEL\_485B
- 3: DATA\_BUS
- 4: PARALLEL\_CANH
- 5: PARALLEL\_CANL
- 6: GND\_COM
- 7: PARALLEL\_SYNC1
- 8: PARALLEL\_SYNC2



#### BMS1

- 1: BAT\_TEMP
- 2: GND\_COM
- 3: GND\_COM
- 4: BMS1\_CANH
- 5: BMS1\_CANL
- 6: BAT\_WAKEUP\_POWER
- 7: BMS1\_485A
- 8: BMS1\_485B

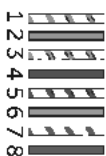

#### BMS2

- 1: BAT\_TEMP
- 2: GND\_COM
- 3: GND\_COM
- 4: BMS2\_CANH
- 5: BMS2\_CANL
- 6: BAT\_WAKEUP\_POWER
- 7: BMS2\_485A
- 8: BMS2\_485B

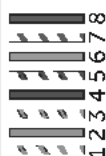

#### RS485

- 1: REMOTE\_485A
- 2: REMOTE\_485B
- 3: NC
- 4: PARALLEL\_485AA
- 5: PARALLEL\_485BB
- 6: NC
- 7: REMOTE\_485A
- 8: REMOTE\_485B

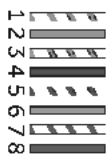

#### DRM

- 1: DRM1/5
- 2: DRM2/6
- 3: DRM3/7
- 4: DRM4/8
- 5: +3.3V\_COM
- 6: COM/DRM0
- 7: GND\_COM
- 8: GND\_COM

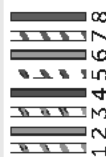

## 8.6.2 Parallel Connection

The inverter provides the parallel connection function. One inverter will be set as the "Master inverter" to control the other "Slave inverters" in the system. For details, please refer to "14.5 Application of Parallel Function".

### Parallel connection wiring procedure

**Step 1:** Loosen the screws on the COM 1 terminal. Pinch the tabs on the sides of the COM 1 connector enclosure and pull it at the same time to disassemble it.

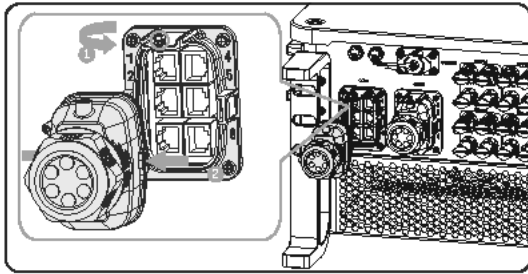

Figure 8-44 Removing the connector enclosure

**Step 2:** Anti-clockwise loosen the swivel nut and pull out the sealing plugs. Keep the sealing plugs still in the cable support sleeve if you choose not to connect the cable.

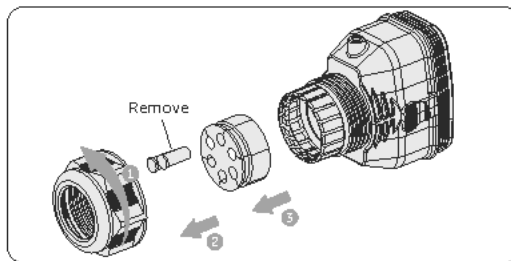

Figure 8-45 Disassembling the connector

**Step 3:** Thread the network cables.

- » **Method 1:** If your network cable has already been connected with RJ45 terminal, you can directly thread the cable through the swivel nut, cable support sleeve and connector enclosure in sequence.

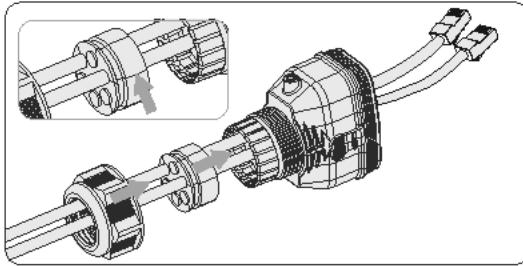

Figure 8-46 Threading the cables with RJ45 terminal

- » Method 2: If your network cable is not connected to an RJ45 terminal, you will need to assemble the cable before proceeding.

Thread the cables without RJ45 terminal through the swivel nut, cable support sleeve, and connector enclosure in sequence. Strip approx. 15 mm of the cable insulation.

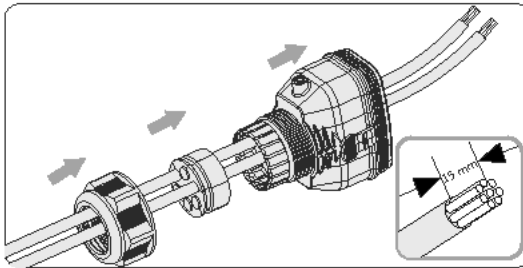

Figure 8-47 Threading the cables and stripping the insulation

Insert the stripped section into the RJ45 terminal. Crimp it tightly with a crimping tool for RJ45. Pay attention to pin order of RJ45 terminal.

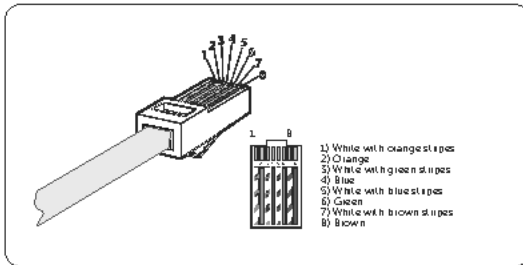

Figure 8-48 Crimping the communication cable

## NOTICE!

- Use network cable tester to test the crimped cable before connecting to the inverter.

**Step 4:** Install the network cables with a crimped RJ45 terminal to Parallel-1 and Parallel-2 of cable fixture according to the labeling.

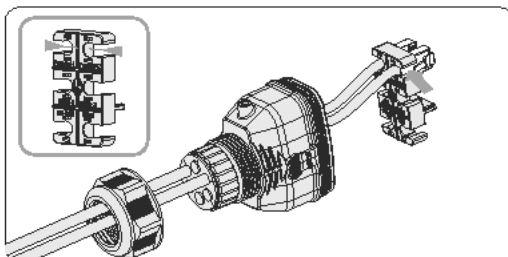

Figure 8-49 Installing the cable to the cable fixture

**Step 5:** Connect the assembled connector to COM 1 terminal. Ensure the cable fixture tongue is well inserted into the slot of terminal. You will hear an audible "Click" if it is connected securely. Lightly pull the cable for double check its connection.

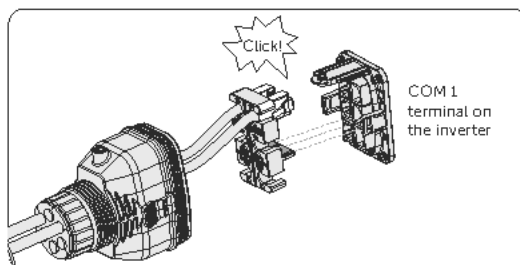

Figure 8-50 Inserting the connector to COM 1

- Step 6:** Secure the assembled connector on COM 1 terminal.
- Install the connector enclosure back into the COM 1 terminal.
  - Install the cable support sleeve into the enclosure.
  - Tighten M3 screw to secure it. (Torque:  $1.2 \pm 0.1$  N·m)
  - Clockwise tighten the swivel nut to finish the COM 1 wiring connection.

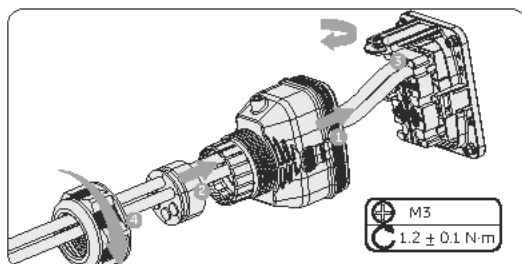

Figure 8-51 Securing the connector

### 8.6.3 BMS Communication Connection

Through BMS-1 and BMS-2 communication terminal, the inverter can be connected to two independent batteries of different capacities. The model of each battery tower must be the same.

#### BMS connection diagram

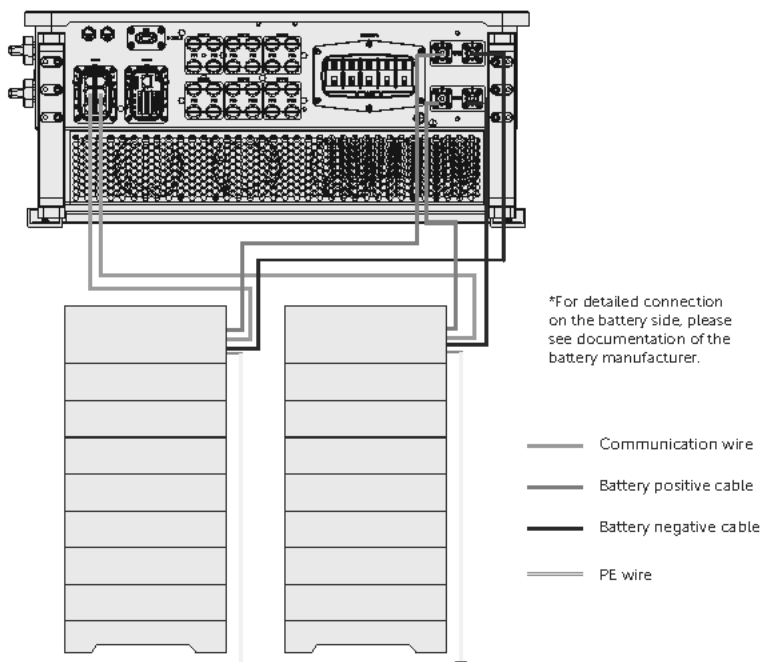

Figure 8-52 BMS connection diagram

### BMS wiring procedure

- Step 1:** Loosen the screws on the COM 1 terminal. Pinch the tabs on the sides of the COM1 connector enclosure and pull it at the same time to remove it.
- Step 2:** Anti-clockwise loosen the swivel nut and pull out the sealing plugs. Keep them still in the cable support sleeve if you choose not to connect the cable.
- Step 3:** Thread the cables through the swivel nut, cable support sleeve, and connector enclosure in sequence.
- Step 4:** Install the network cables to BMS-1 and BMS -2 of cable fixture according to the labeling.

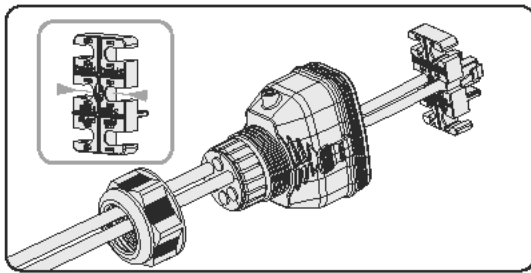

Figure 8-53 Installing RJ45 terminal to the cable fixture

- Step 5:** Connect the assembled connector to COM 1 terminal. Make sure the cable fixture tongue is well inserted into the slot of terminal. You will hear an audible "Click" if it is connected securely. Lightly pull the cable backward for double check its connection.
- Step 6:** Secure the assembled connector on COM 1 terminal.
- Install the connector enclosure back into the COM 1 terminal.
  - Install the cable support sleeve into the enclosure.
  - Tighten M3 screw to secure it. (Torque:  $1.2 \pm 0.1$  N·m)
  - Clockwise tighten the swivel nut to finish the COM 1 wiring connection.

### 8.6.4 RS485 Communication Connection

For SolaX products, such as the Adapter Box, EV-Charger and etc., they can be connected to pin4 and pin5. As for pin1, pin2, pin7,and pin8 they can be utilized to connect devices other than SolaX products. If you require simultaneous connections of multiple devices, a splitter adapter can be employed.

#### NOTICE!

- Please refer to "14 Appendix" for the specific application of Adapter Box, EV-Charger and Datahub.
- Not all devices are compatible with 8 pin Network cables. In cases where 8 pin Network cables are not supported, it is required to re-crimp the RJ45 terminal according to the pin assignment.

#### External equipment wiring procedure

- Step 1:** Loosen the screws on the COM 1 terminal. Pinch the tabs on the sides of the COM 1 connector enclosure and pull it at the same time to remove it.
- Step 2:** Anti-clockwise loosen the swivel nut and pull out the sealing plugs. Keep the sealing plugs still in the cable support sleeve if you choose not to connect the cable.

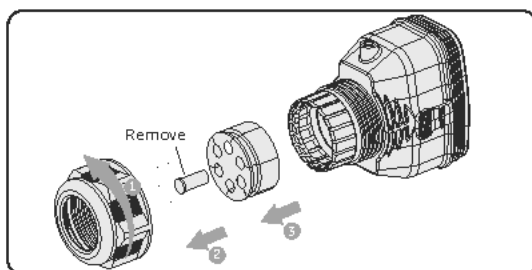

Figure 8-54 Disassembling the connector

- Step 3:** Thread the cables without RJ45 terminal through the swivel nut, cable support sleeve, and connector enclosure in sequence. Strip approx. 15 mm of the cable insulation.

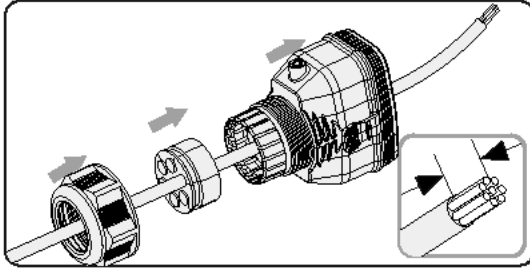

Figure 8-55 Threading the cables and stripping the insulation

**Step 4:** Insert the stripped section into the RJ45 terminal. Crimp it tightly with a crimping tool for RJ45. Pay attention to pin order of RJ45 terminal.

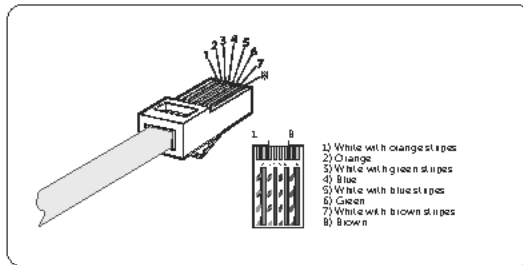

Figure 8-56 Crimping the communication cable

#### NOTICE!

- Use network cable tester to test the crimped cable before connecting to the inverter.

**Step 5:** Install the network cable of the crimped RJ45 terminal to RS485 of cable fixture according to the labeling.

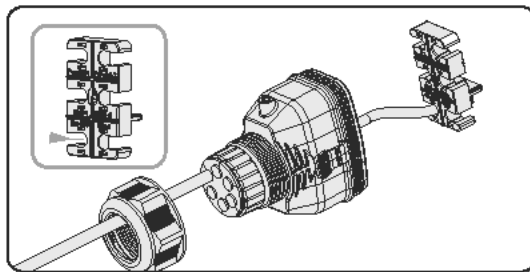

Figure 8-57 Installing RJ45 terminal to the cable fixture

**Step 6:** Connect the assembled connector to COM 1 terminal. Make sure the cable fixture

tongue is well inserted into the slot of terminal. You will hear an audible "Click" if it is connected securely. Lightly pull the cable backward for double check its connection.

**Step 7:** Secure the assembled connector on COM 1 terminal.

- Install the connector enclosure back into the COM 1 terminal.
- Install the cable support sleeve into the enclosure.
- Tighten M3 screw to secure it. (Torque:  $1.2 \pm 0.1$  N·m)
- Clockwise tighten the swivel nut to finish the COM 1 wiring connection.

### 8.6.5 DRM Connection (Applicable to AS/NZS 4777)

According to AS/NZS 4777, the inverter needs to support the function of demand response mode (DRM). With the use of an external control box, active or reactive power regulation can be realized in a timely and fast manner, and the inverter can be operated stably during the process of regulation.

DRM 0, DRM 1 and DRM 5 are available now.

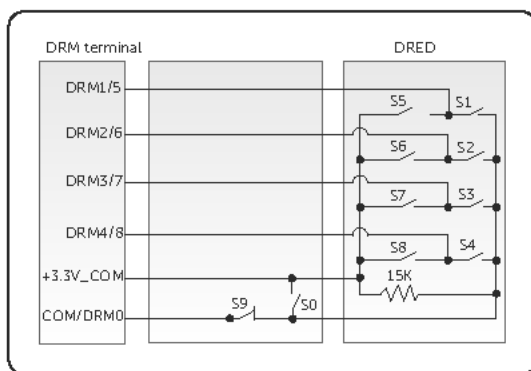

Figure 8-58 DRED connection diagram

Table 8-5 Descriptions of DRM

Mode	Pin	Requirement
DRM 0	Pin 6	<ul style="list-style-type: none"> <li>When S0 is turned on, the inverters shut down.</li> <li>When S0 is turned off, the inverters restore grid connection.</li> </ul>
DRM 1	Pin 1	<ul style="list-style-type: none"> <li>When S1 is turned on, the inverters do not input active power.</li> </ul>
DRM 5	Pin 1	<ul style="list-style-type: none"> <li>When S5 is turned on, the inverters do not output active power.</li> </ul>

### DRM connection wiring procedure

- Step 1:** Loosen the screws on the COM 1 terminal. Pinch the tabs on the sides of the COM 1 connector enclosure and pull it at the same time to remove it.
- Step 2:** Anti-clockwise loosen the swivel nut and pull out the sealing plugs. Keep them still in the cable support sleeve if you choose not to connect the cable.
- Step 3:** Thread the cable through the swivel nut, cable support sleeve, and connector enclosure in sequence.
- Step 4:** Install the network cable of the crimped RJ45 terminal to RS485 of cable fixture according to the labeling.

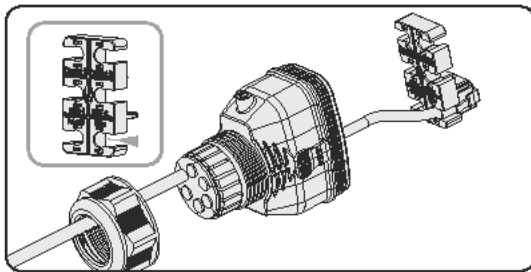

Figure 8-59 Installing RJ45 terminal to the cable fixture

- Step 5:** Connect the assembled connector to COM 1 terminal. Make sure the cable fixture tongue is well inserted into the slot of terminal. You will hear an audible "Click" if it is connected securely. Lightly pull the cable backward for double check its connection.
- Step 6:** Secure the assembled connector on COM 1 terminal.
- Install the connector enclosure back into the COM 1 terminal.
  - Install the cable support sleeve into the enclosure.
  - Tighten M3 screw to secure it. (Torque:  $1.2 \pm 0.1$  N·m)
  - Clockwise tighten the swivel nut to finish the COM 1 wiring connection.

## 8.7 COM 2 Communication Connection

### 8.7.1 Pin Assignment of COM 2 Terminal

The COM 2 terminal is used for Meter/CT connection, ripple control and DIO function.

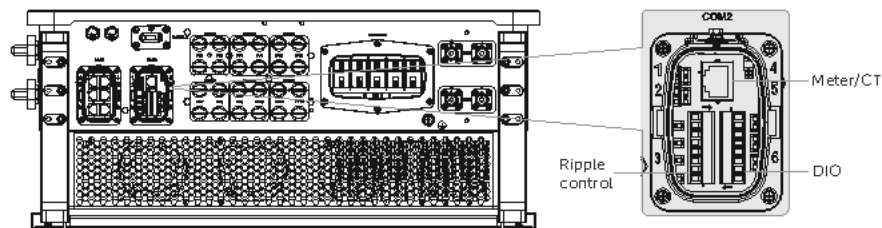

Table 8-6 Pin assignment of COM 2 terminal

Pin	Pin assignment
Meter/CT	
1	CT_R1_CON
2	CT_S1_CON
3	CT_T1_CON
4	METER_485A
5	METER_485B
6	CT_T2_CON
7	CT_S2_CON
8	CT_R2_CON
Ripple control	
1	RP_K4
2	GND_COM
3	RP_K3
4	GND_COM
5	RP_K2
6	GND_COM
7	RP_K1

Pin	Pin assignment
8	GND_COM
DIO port	
1	DO_1
2	DO_2
3	DI_1+
4	DI_1-
5	DI_2+
6	DI_2-
7	GND_COM
8	EPSBOX_RELAY_VCC

### 8.7.2 Meter/CT Connection

The inverter should work with an electric meter or current transformer (CT for short) to monitor household electricity usage. The electricity meter or CT can transmit the relevant electricity data to the inverter or platform.

#### CAUTION!

- The inverter will shut down and prompt **Meter Fault** alarm if meter is not connected to inverter. Smart meters must be authorized by our company. Unauthorized meter may be incompatible with the inverter. SolaX will not be responsible for the impact caused by the use of other appliances.

#### NOTICE!

- Do not place the CT on the N wire or ground wire.
- Do not put CT on the N line and L line at the same time.
- Do not place the CT on the side where the arrow points to the inverter.
- Do not place the CT on non-insulated wires.
- The cable length between CT and inverter should not exceed 10 meters.
- It is recommended to wrap the CT clip around in circles with insulating tape.

Meter/CT connection diagram

**NOTICE!**

- The following figures take inverter with Meter DTSU666 and inverter with Meter DTSU666-CT as an example.
- If you have other power generation equipment (such as an inverter) at home and wants to monitor both equipment, our inverter provides Meter 2 communication function to monitor the power generation equipment. For more information, please contact us.
- Please make PE connection for Meter if the meter has ground terminal.

- Meter connection diagram

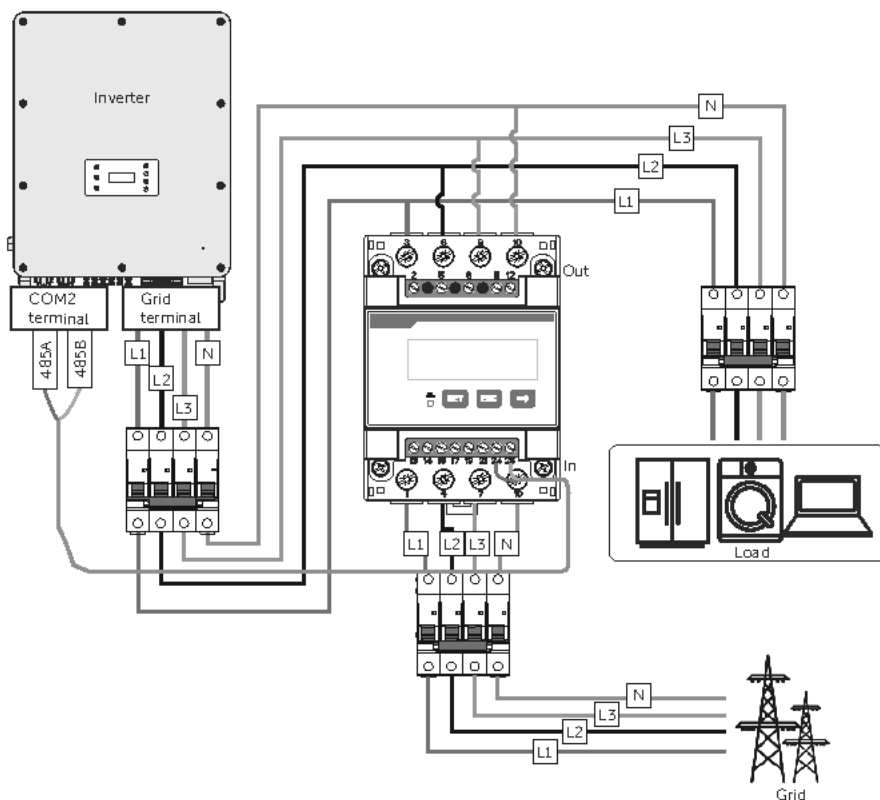

Figure 8-60 Meter connection diagram 1

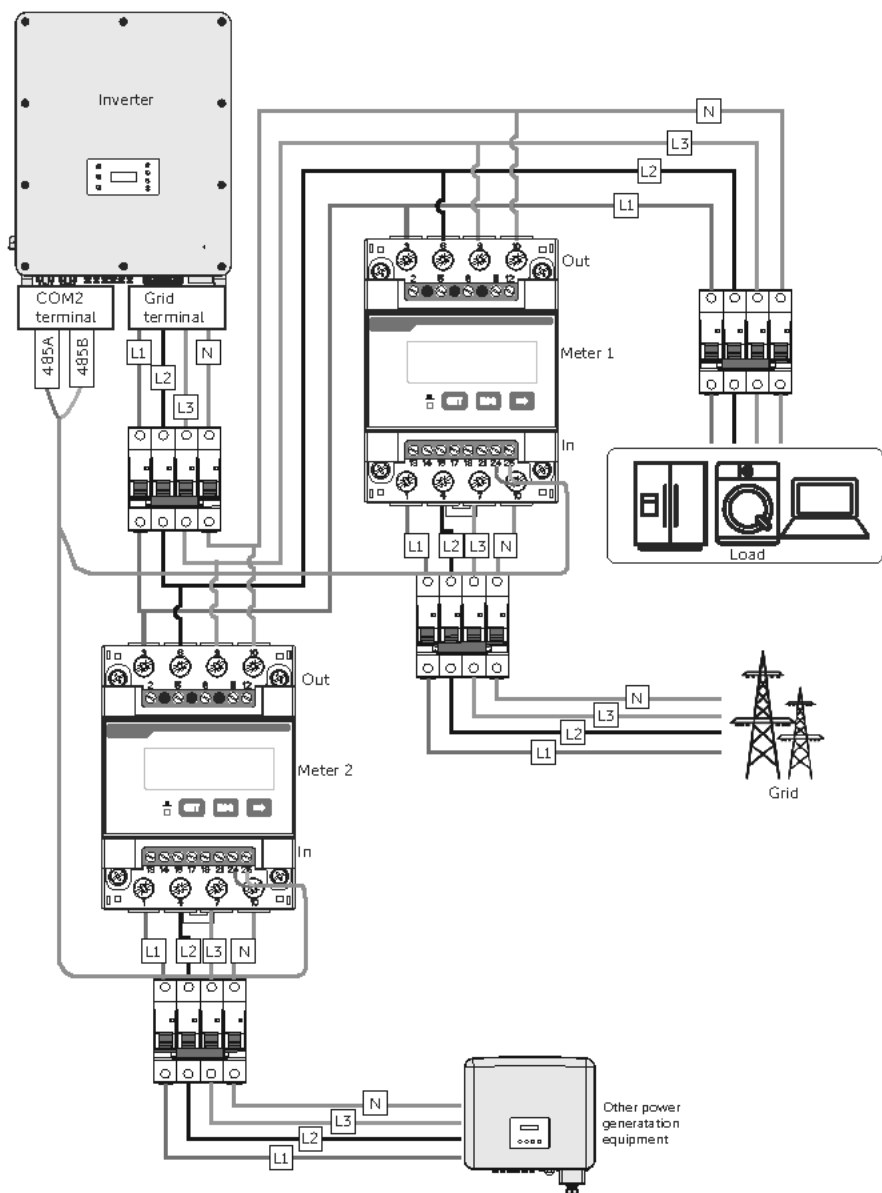

Figure 8-61 Meter connection diagram 2

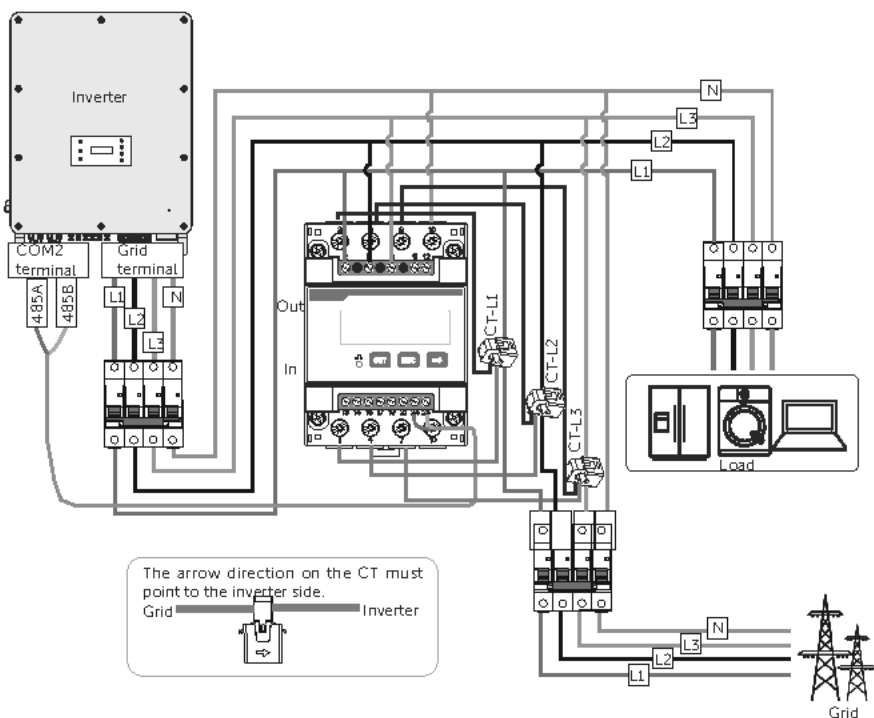

Figure 8-62 Meter with CT connection diagram

**NOTICE!**

- The arrow on the CT must point at the inverter.
- Markings on the CTs might be R, S and T or L1, L2 and L3. Make sure to clip CT-R/CT-L1 to the L1 wire, CT-S/CT-L2 to the L2 wire, and CT-T/CT-L3 to the L3 wire.

- CT connection diagram

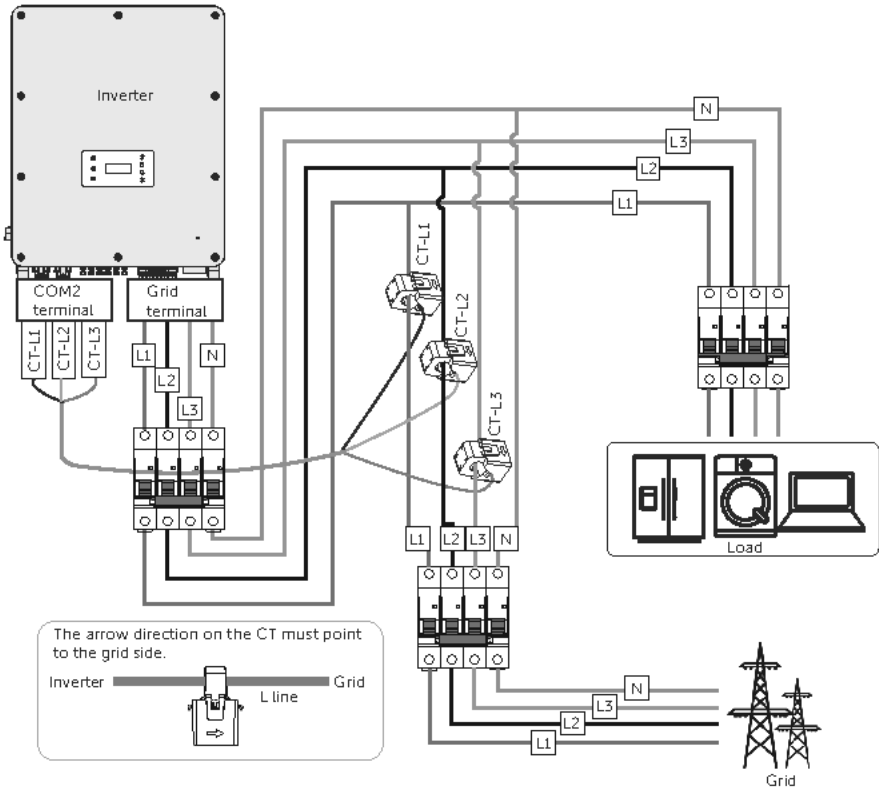

Figure 8-63 CT connection diagram

## NOTICE!

- The arrow on the CT must point at the public grid.
- Markings on the CTs might be R, S and T or L1, L2 and L3. Make sure to clip CT-R/CT-L1 to the L1 wire, CT-S/CT-L2 to the L2 wire, and CT-T/CT-L3 to the L3 wire.

Meter/CT pin definition

	Pin	Pin assignment
For CT connection	1	CT_R1_CON
	2	CT_S1_CON
	3	CT_T1_CON
For Meter connection	4	METER_485A
	5	METER_485B
For CT connection	6	CT_T2_CON
	7	CT_S2_CON
	8	CT_R2_CON

Meter/CT wiring procedure

**Step 1:** Loosen the screws on the COM 2 terminal. Pinch the tabs on the sides of the COM 2 connector enclosure and pull it at the same time to remove it.

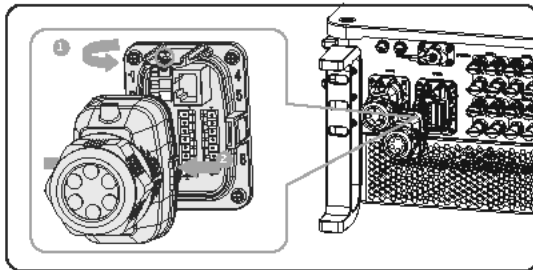

Figure 8-64 Disassembling the COM 2 terminal

**Step 2:** Loosen the swivel nut and pull out the sealing plugs. Keep them still in the cable support sleeve if you choose not to connect the cable.

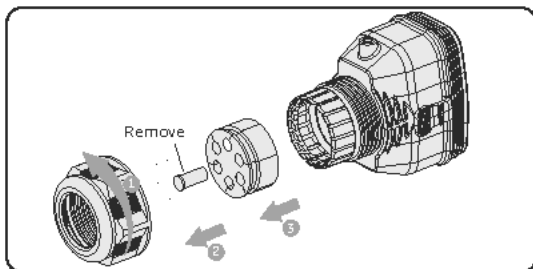

Figure 8-65 Disassembling the connector

**Step 3:** Directly thread the cable through the swivel nut, cable support sleeve and connector enclosure in sequence.

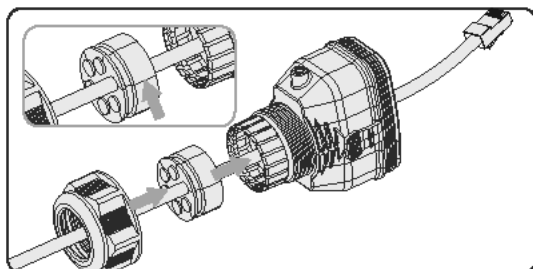

Figure 8-66 Threading the cable with RJ45 terminal

**NOTICE!**

- Use network cable tester to test the crimped cable before connection.

**Step 4:** Connect the assembled communication cable into the COM 2 terminal. Secure the assembled connector on COM 2 terminal.

- » Install the connector enclosure back into the COM 2 terminal.
- » Install the cable support sleeve into the enclosure.
- » Tighten M3 screw to secure it. (Torque:  $1.2 \pm 0.1$  N·m)
- » Clockwise tighten the swivel nut to finish the COM 2 wiring connection.

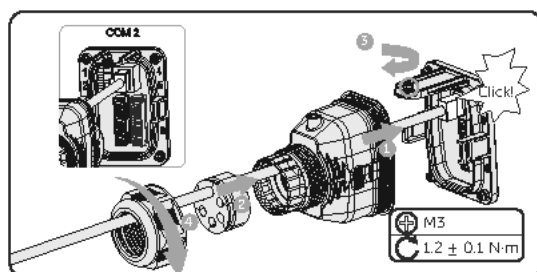

Figure 8-67 Connecting to COM 2

**Step 5:** For a meter connection, insert another side of the communication cable into meter. For CT connection, connect the other side to CT.

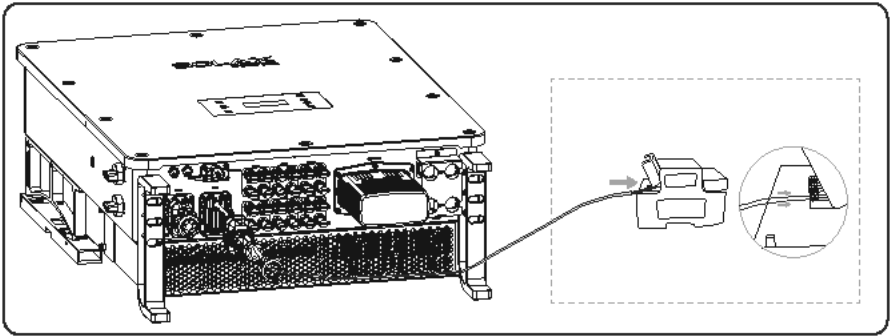

Figure 8-68 Connecting to wire meter

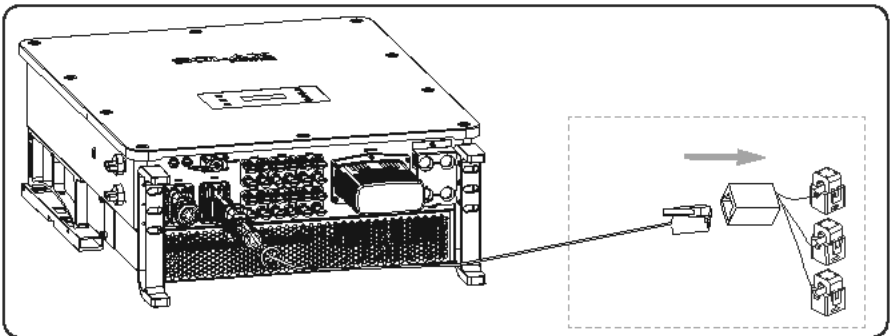

Figure 8-69 Connecting to CT

### 8.7.3 Ripple Control Communication Connection

Ripple Control is a common form of grid management. Its communication is based on superimposing a very high frequency signal onto the 50 / 60 Hz mains power. The inverter supports to connect a digital signal source (e.g. ripple control receiver) to the digital input.

#### Requirments for Ripple control

- The signal source must be technically suitable for connection to the digital inputs. (see technical data)
- The connected digital signal source has a safe separation to the grid potential.

#### Connection diagram for ripple control

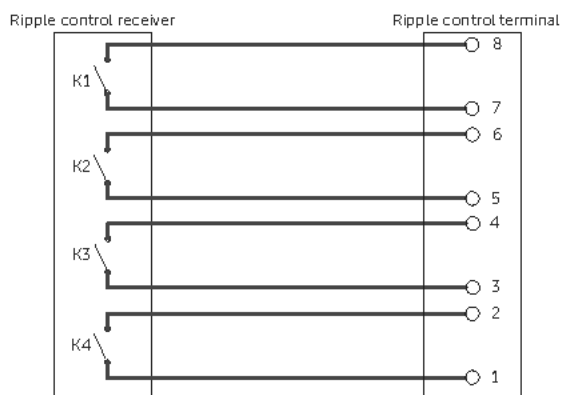

Figure 8-70 Connection diagram for ripple control

#### Ripple control wiring procedure

- Step 1:** Loosen the screws on the COM 2 terminal. Pinch the tabs on the sides of the COM 2 connector enclosure and pull it at the same time to remove it.

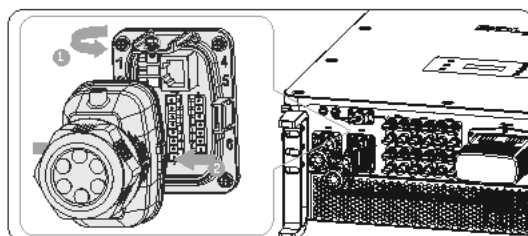

Figure 8-71 Disassembling the COM 2 terminal

**Step 2:** Loosen the swivel nut and pull out the sealing plugs. Keep them still in the cable support sleeve if you choose not to connect the cable.

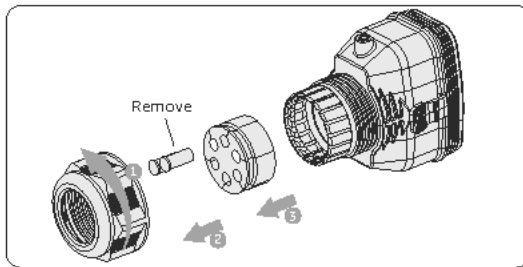

Figure 8-72 Disassembling the connector

**Step 3:** Prepare two four-core signal cables. Thread the cables through the swivel nut, cable support sleeve, and connector enclosure in sequence.

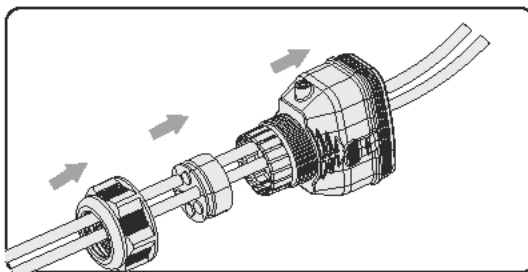

Figure 8-73 Threading the cables

**Step 4:** Strip approx. 6 mm of the cable insulation. Insert the conductors into the 8-pin terminal block and tighten the terminal block screws. (torque:  $0.4 \pm 0.1$  N·m) Ensure that the conductors are firmly seated in the terminal.

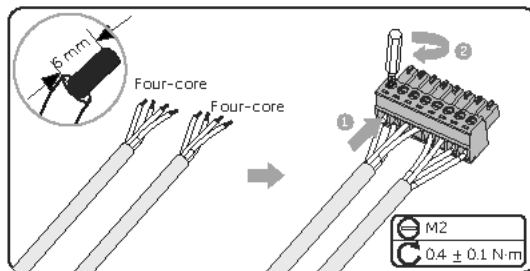

Figure 8-74 Connecting to 8-pin terminal block

**Step 5:** Connect the assembled communication cable into the COM 2 terminal. Lightly pull the cable backward to confirm tight insertion and then install the connector back.

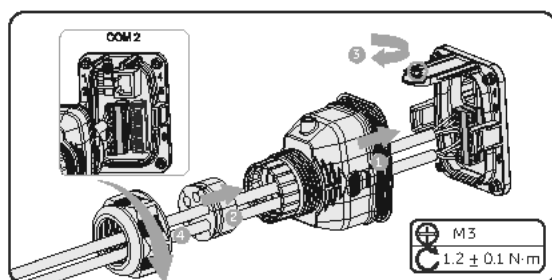

Figure 8-75 Connecting to the inverter

### 8.7.4 DIO Communication Connection

DIO terminal is designed to support generator and system switch connection through dry contact.

To enhance safety and reduce the risk of injury, you can install the system switch in a readily accessible location through dry contact connection. In the event of an emergency, the system switch can be easily reached and pressed to promptly switch off the entire system, ensuring a swift response and preventing further harm.

For generator, please refer to "14.1 Generator Application" for specific application.

#### DIO pin definition

	Pin	Pin assignment
For generator dry contact output	1	DO_1
	2	DO_2
For system switch dry contact input	3	DI_1+
	4	DI_1-
Reserved	5	DI_2+
	6	DI_2-
Reserved	7	GND_COM
For power supply	8	EPSBOX_RELAY_VCC

#### NOTICE!

- If there is strong interference in the surroundings, it is recommended to use shielding cables and ground the shielding layer of the cables through Pin 7.

System switch connection diagram

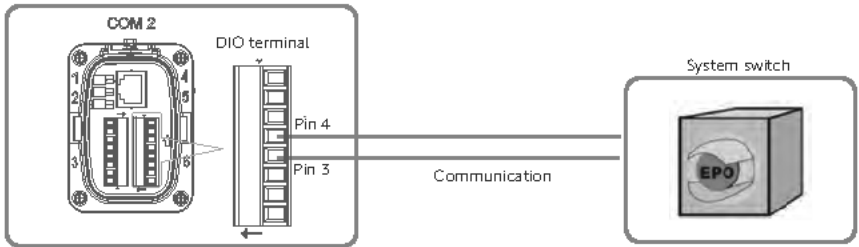

Figure 8-76 System switch connection diagram

Choose a self-locking switch for the system. When system switch is pressed, **OFF MODE (DIO SW)** will be displayed on the LCD screen and the system will be powered off. To release the switch, press it again.

DIO wiring procedure

- Step 1:** Loosen the screws on the COM 2 terminal. Pinch the tabs on the sides of the COM 2 connector enclosure and pull it at the same time to remove it.
- Step 2:** Loosen the swivel nut and pull out the sealing plugs. Keep them still in the cable support sleeve if you choose not to connect the cable.
- Step 3:** Prepare two four-core signal cable. Thread the cables through the swivel nut, cable support sleeve, and connector enclosure in sequence.
- Step 4:** Strip approx. 6 mm of the cable insulation. Insert the conductors into the 8-pin terminal block and tighten the terminal block screws. (torque:  $0.4 \pm 0.1$  N·m) Ensure that the conductors are firmly seated in the terminal.

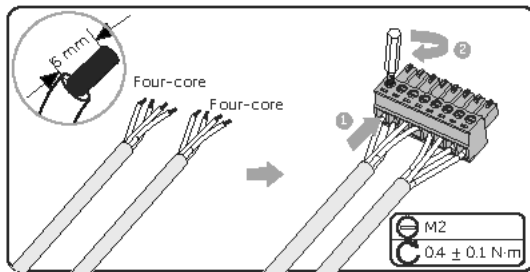

Figure 8-77 Connecting to 8-pin terminal block

- Step 5:** Connect the assembled communication cable into the COM 2 terminal. Lightly pull the cable backward to confirm tight insertion and then install the connector back.

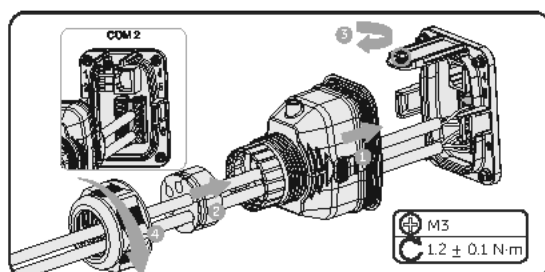

Figure 8-78 Connecting to the inverter

## 8.8 Monitoring Connection

The inverter provides a DONGLE terminal, which can transmit data of the inverter to the monitoring website via WiFi+Lan dongle (Optional). The WiFi+Lan dongle is equipped with two kinds of communication modes (Wi-Fi mode or LAN mode). Users can choose based on actual needs. (If needed, purchase products from us.)

### Monitoring connection diagram

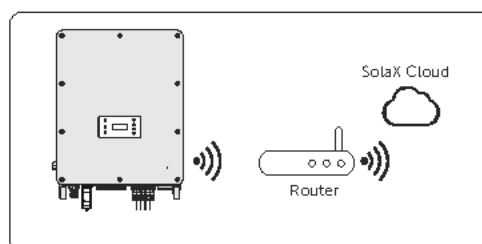

Figure 8-79 Wi-Fi mode connection diagram

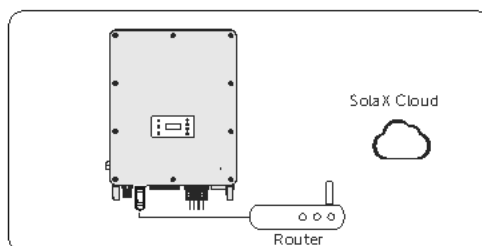

Figure 8-80 LAN mode connection diagram

## Monitoring wiring procedure

Wi-Fi mode:

- a. Assemble the dongle,.

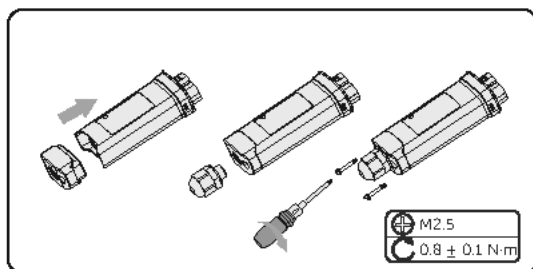

Figure 8-81 Assembling the dongle

- b. Plug the dongle to the inverter

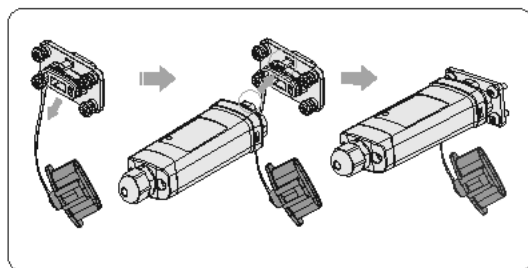

Figure 8-82 Wi-Fi connection procedure

### ⚠ CAUTION!

- The buckles on the inverter and dongle must be on the same side. Otherwise, the dongle may be damaged.

### NOTICE!

- The longest connection distance between the router and the equipment should be no more than 100 meters; if there is a wall between the router and the equipment, the longest connection distance is 20 meters.
- When the Wi-Fi signal is weak, please install a Wi-Fi signal booster at the appropriate location.

## NOTICE!

- Please refer to "Pocket WiFi + LAN Installation Guide" for instructions on configuring the Wi-Fi. It is important to note that the Wi-Fi configuration should be performed after powering on the inverter.

LAN mode:

- Disassemble the waterproof connector into components **1**, **2**, **3** and **4**; Component **1** is not used. Keep it in a safe place.

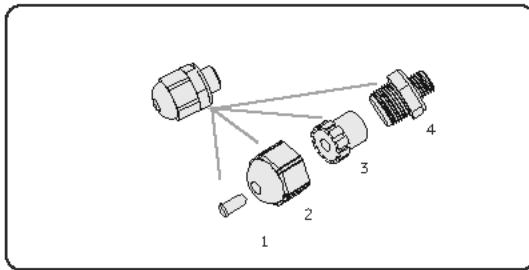

Figure 8-83 Disassembling the waterproof connector

- Assemble the dongle.

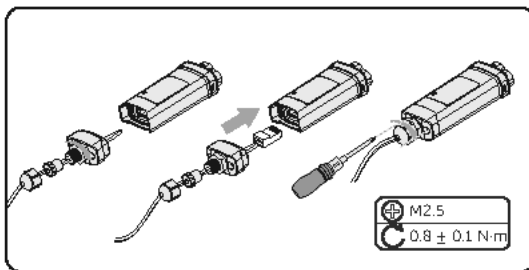

Figure 8-84 Assembling the LAN dongle

- Plug the dongle to the inverter.

## 9 System Commissioning

---

### 9.1 Checking before Power-on

No.	Item	Checking details
1	Installation	The inverter is installed correctly and securely. The battery is installed correctly and securely. Other device (if any) is installed correctly and securely.
2	Wiring	All DC, AC cables and communication cables are connected correctly and securely; The meter/CT is connected correctly and securely. The ground cable is connected correctly and securely;
3	Breaker	All the DC breakers and AC breakers are OFF;
4	Connector	The external AC and DC connectors are connected; The connectors on the Grid and EPS terminal are connected correctly and securely.
5	Unused terminal	Unused terminals and ports are locked by waterproof caps.
6	Photovoltaic panel	All photovoltaic panels are connected correctly and securely.
7	Screw	All the screws are tightened.

### 9.2 Powering on the System

**Step 1:** Turn on the AC breakers and check whether the LCD screen lights on.

- » If the LCD screen is not on, turn off the AC breakers and check whether the Grid cable is connected correctly and securely.

**Step 2:** Switch on the inverter DC switch and check the LCD screen, refer to "PV status" to check the PV voltage.

- » If the PV voltage is 0, turn off the the DC switch, pull out the PV connectors and then measure the voltage of the positive and negative PV port (in MPPT voltage range 160-950 V) or check whether the positive and negative poles of PV cables are reversed.

**Step 3:** Switch on the battery or the breaker, button, DC switch of the battery. (see documentation of the battery manufacturer)

**Step 4:** Press and turn on the inverter system button.

**Step 5:** Set "System ON/OFF" as ON status on the inverter screen, and the LCD displays waiting status.

- Step 6:** When the photovoltaic panels generate enough power or the battery supplies power, the inverter will start automatically. The inverter will go Waiting, Checking and Normal status in sequence.
- Step 7:** Check whether the meter/CT is correctly connected.
- » If CT is connected, please perform the Meter/CT Check to check the correct connection through the setting path: **Menu>Setting>Advance Setting>Meter/CT Settings>Meter/CT Check**
  - » If meter is connected, please set the connection of Meter through the setting path: **Menu>Setting>Advance Setting>Meter/CT Settings.**

**NOTICE!**

- When the meter or CT is correctly connected, the meter/CT power displays on the METER/CT check interface; when the connection method is wrong, "Meter Fault" displays on this interface.

### 9.3 Checking after Powering on

- a. Check whether the inverter has any abnormal noise.
- b. Check whether the indicator lights report an error and whether the LCD screen displays the error message.
- c. Check whether the data of PV, grid and battery are normal through the LCD screen.
- d. Check whether the Work Mode is consistent with what had been set through LCDscreen or the SolaX Cloud App.

# 10 Operation on LCD

## 10.1 Introduction of Control Panel

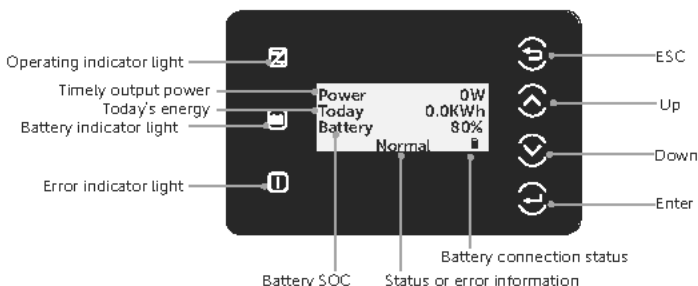

Figure 10-1 Control Panel

- In a normal state, the "Power", "Today" and "Battery" information will be displayed. You can press the keys to switch information.
- In an error state, the fault message and error code will be displayed, please refer to "11.3 Troubleshooting" for corresponding solutions.

Table 10-1 Definition of indicators

















LED indicator	Status	Definition
 Operating	 Light on	The inverter is in a normal state.
	 Blinking	The inverter is in a waiting or checking state.
 Error	 Light on	The inverter is in a fault state.
	 Blinking	Both of the battery terminals are connected are in an idle state.
 Battery	 Light on	One of the battery terminal is connected in a normal state at least.
	 Blinking	Both of the battery terminals are disconnected.
	 Solid display	One of the battery terminals is connected normally at least.
	 Blinking	Both of the battery terminals are disconnected.

Table 10-2 Definition of keys

Key	Definition
 ESC key	Exit from the current interface or function
 Up key	Move the cursor to the upper part or increase the value
 Down key	Move the cursor to the lower part or decrease the value
 Enter key	Confirm the selection

## 10.2 Introduction of Menu Interface

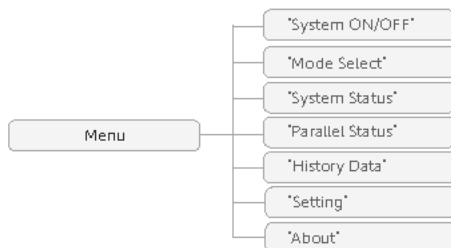

There are seven submenus in the menu that can be selected for relevant setting operations.

- **System ON/OFF:** Switch on and off the inverter.
- **Mode Select:** Select the working mode of the inverter, including **Self Use, Feed-in Priority, Backup Mode, Manual, Peaking Shaving** and **TOU Mode**.

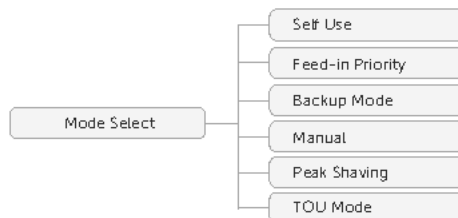

- **System Status:** Display the real-time value of PV, battery, etc. Including **PV1, PV2, PV3, PV4, PV5, PV6, Battery 1, Battery 2, On-grid, EPS** and **Meter/CT**.

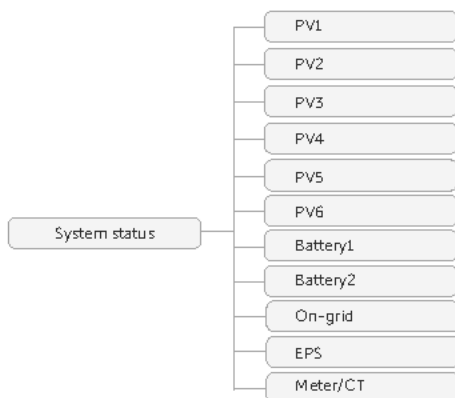

- **Parallel Status:** Display all the status data from master inverter when the inverters are parallel-connected.
- **History Data:** Display the history data of **On-grid**, **EPS**, **E\_Feedin**, **E\_USERDEF** and **Error Log**.

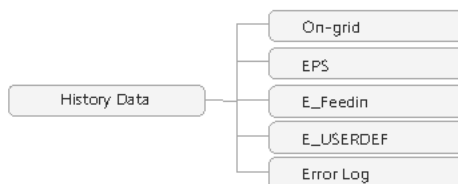

- **Setting:** Set the parameters of inverter, including **User Setting** and **Advance Setting**.

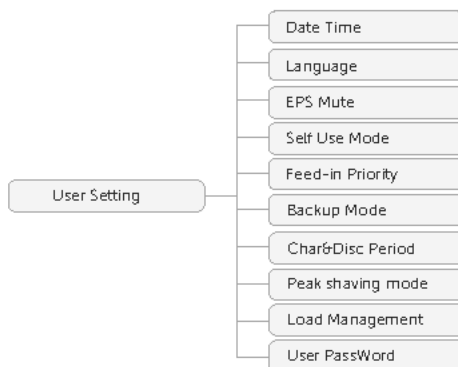

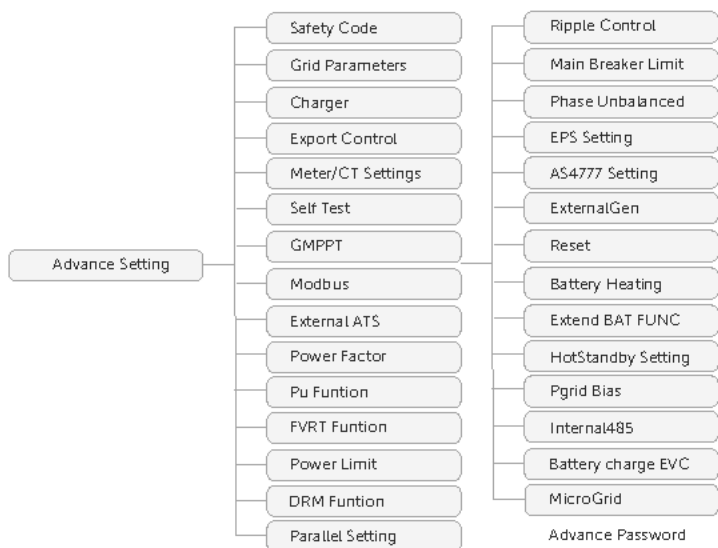

- **About:** Display the information about **Inverter**, **Battery 1**, **Battery 2** and **Internal code**.



### 10.3 System ON/OFF

Setting path: **Menu>System ON/OFF**

Select **ON** or **OFF** to switch on and off the inverter. The interface is displayed **ON** by default. When you select **OFF**, the inverter stops running and display **System OFF**.

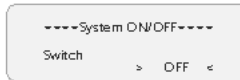

### 10.4 Mode Select

Selecting path: **Menu>Mode Select**

Here you can only select the working mode. Six working modes are available for you to choose in on-grid status, i.e Self-use mode, Feedin Priority, Backup, Peak shaving mode, TOU Mode and Manual. You can choose the working modes according to your lifestyle and environment. Please refer to "2.7 Working Mode" for introduction of the modes and "10.8.1 User Setting" for specific setting of each mode.



### 10.5 System Status

Displaying path: **Menu>System Status**

After entering into the **System Status** interface, the status of PV, Battery, On-grid, EPS, Meter/CT will be displayed on the LCD as follows:

- PV status: You can see information of **PV1**, **PV2**, **PV3**, **PV4**, **PV5** and **PV6**. Information contains input voltage, current and power of each PV. For X3-AELIO-50K and X3-AELIO-49.9K inverter, the value of **PV6** is 0.



- Battery status: There will be information of **Battery1** and **Battery2** displayed here. It shows the status of each battery terminal, including the voltage, current, power, SOC, temperature and BMS connection status. Positive value with current and power means charging; Negative value means discharging.



- On-grid status: Information contains the voltage, current, frequency, and output power of **Grid** terminal. The "A", "B" and "C" in On-grid A, On-grid B and On-grid C refers to L1, L2 and L3 respectively. The figure below will take On-grid A as an example.



- EPS status: Information contains apparent power, voltage, current, active power and frequency of **EPS** terminal when it is disconnected from the grid. The "A", "B" and "C" in EPS A, EPS B and EPS C refers to L1, L2 and L3 respectively. The figure below will take EPS A as an example.

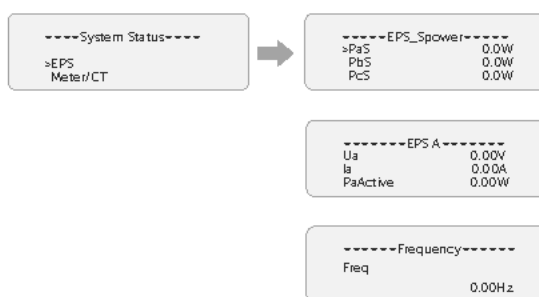

- Meter/CT status: Information contains feed-in power of L1, L2 and L3 detected by the connected meter or CT.



## 10.6 Parallel Status

Displaying path: **Menu>Parallel Status**

### NOTICE!

- Once inverter enters parallel system, the **Today** yield will be replaced by **Parallel**.

In **Parallel Status** interface, the whole system power and individual slave inverter power can be obtained in **Parallel Status** interface of master inverter. The number displayed in the **Parallel Status** interface refers to the total number of online inverters, for example two inverters in parallel in the below figure.

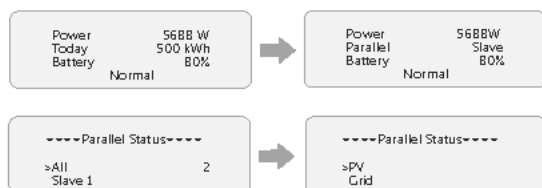

## 10.7 History Data

Displaying path: **Menu>History Data**

After entering into the **History Data** interface, the status of **On-grid**, **EPS**, **E\_Feedin**, **E\_USERDEF**, **Error Log** will be displayed on the LCD as follows:

- On-grid:** A record of the output and input electric energy of inverter from grid today and the total. (through **Grid** terminal)
  - » **Output Today:** Output electric energy of inverter today.
  - » **Output Total:** Total output electric energy since the inverter activated for the first time.
  - » **Input Today:** Input electric energy of inverter today.
  - » **Input Total:** Total input electric energy since the inverter activated for the first time.

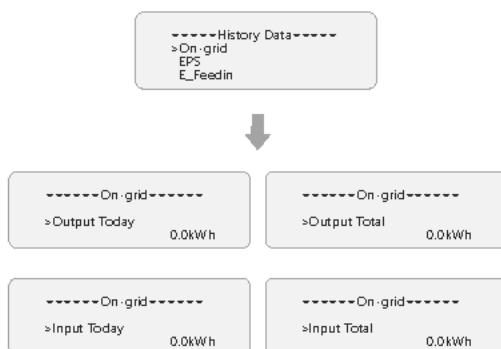

- **EPS:** A record of the output electric energy of the inverter today and the total when it is disconnected from grid. (through **EPS** terminal)

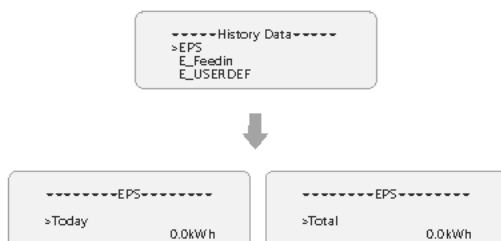

- **E\_Feedin:** The total electricity fed into or taken from the grid since the inverter activated for the first time and on that day. (detected by Meter/CT)
  - » **Feedin Today:** Electricity sold to grid today.
  - » **Feedin Total:** Total electricity sold to grid since the inverter activated for the first time.
  - » **Consume Today:** Electricity bought from grid today.
  - » **Consume Total:** Total electricity bought from grid since the inverter activated for the first time.

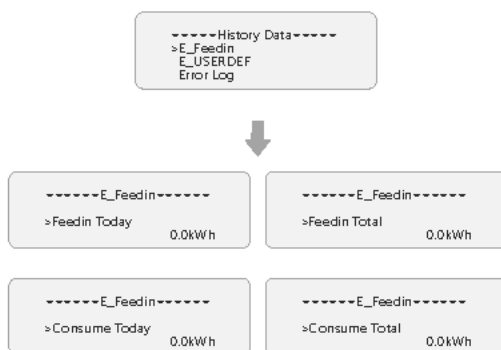

- **E\_USERDEF:** The output electricity of the connected on-grid inverter today and the total.(detected by Meter 2) This function is only available when meter 2 is connected.

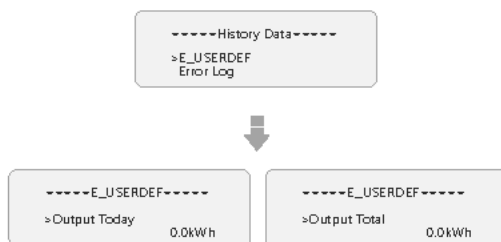

- **Error Log:** Display the recent six error messages. Information contains date and time error happened, error code and error description.



## 10.8 Setting

Settings includes User Settings and Advanced Settings.

### 10.8.1 User Setting

Setting path: **Menu>Setting ("0 0 0 0 ")>User Setting**

#### NOTICE!

The default password for **User Setting** is "0 0 0 0".

### Setting Date & Time

You can set the current date and time of the installation site.

The display format is "2023-06-16 14:00", in which the first four numbers represent the year (e.g. 2000~2099); the fifth and sixth numbers represent the month (e.g. 01~12); the seventh and the eighth numbers represent the date (e.g. 01~31). The remaining numbers represent the time.



### Setting Language

This inverter provides multiple languages for customers to choose, such as English, Deutsch, francais, Polskie, Espanol, Portugués. The default language is English.



### Setting EPS Mute

When the inverter is running in EPS Mode, you can choose whether the buzzer is turned on or not.

- Select **Yes**, the buzzer mutes.
- Select **NO**, the buzzer will sound once every 4 seconds if the battery SOC is > EPS min. SOC. When the battery SOC is equal to EPS min SOC, the buzzer will sound with higher frequency at every 400 ms. And turn off the sound when the battery SOC is < EPS min SOC. This function is turned off by default.



## Setting Self Use Mode

Please refer to “2.7.1 Self-use Mode” for working logic of this mode.

- **Min SOC:** Default: 10%; range: 10%~100%
  - » The minimum SOC of the battery. The battery will not discharge power when the SOC of the battery reaches this value.



- **Charge from grid:**
  - » You can set whether the power can be taken from the grid to charge the battery. When **Charge from grid** is set to **Enable**, the utility power is allowed to charge the battery; when it is set to **Disable**, the utility power is not allowed to charge the battery.



- **Charge battery to:** Default: 10%; range: 10%~100%
  - » Set the SOC to charge the battery from grid (applicable only when the **Charge from grid** is enabled).
  - » You can set your own target value, i.e. during the forced charging period, the inverter will use both PV & GRID energy to charge the battery SOC to the target SOC value, after the battery SOC meets the target value, if the PV energy is still sufficient (enough for load and there is excess power), the inverter will continue to use PV energy to charge the battery.

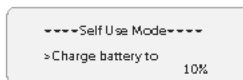

## Setting Feed-in Priority

Please refer to “2.7.2 Feed-in Priority” for working logic of this mode.

- **Min SOC:** Default: 10%; range: 10%~100%
  - » The minimum SOC of the battery. The battery will not discharge power when the SOC of the battery reaches this value.



- **Charge battery to:** Default: 50%; range: 10%~100%
  - » Set the SOC to charge the battery from grid.
  - » You can set your own target value, i.e. during the forced charging period, the inverter will use both PV & GRID energy to charge the battery SOC to the target SOC value, after the battery SOC meets the target value, if the PV energy is still sufficient, the surplus power will be fed into the grid.

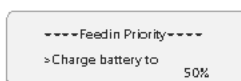

### Setting Backup Mode

Please refer to "2.7.3 Backup Mode" for working logic of this mode.

- **Min SOC:** Default: 30%; range: 30%~100%
  - » The minimum SOC of the battery. The battery will not discharge power when the SOC of the battery reaches this value.



- **Charge battery to:** Default: 50%; range: 30%~100%
  - » In this mode, the charge from grid function is turned on by default, and customers can set the target value by themselves, that is, during the forced charging period, the inverter will cooperate with PV&GRID to charge the battery to the target value. if the PV energy is still sufficient (enough for load and there is excess power), the inverter will continue to use PV energy to charge the battery.

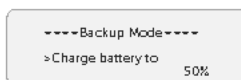

### Setting Char&Disc Period

#### NOTICE!

- The charging and discharging period is only applicable for self-use mode, feed-in priority and backup mode.

Here you can set the **Forced Charge Period** and **Allowed Disc Period**.

If two charging and discharging periods are needed, enable the **Function Control** to activate the **Char&DischrgPeriod2**.

- **Char&Disc Period:** You can set the charge and discharge time according to your own needs. The default time axis of the system is 24h.
  - » **Forced Charge Period Start Time:** Time to start charging; default:00:00; range: 00:00~23:59
  - » **Forced Charge Period End Time:** Time to stop charging; default:00:00; range: 00:00~23:59
  - » **Allowed Disc Period Start Time:** Time allows to start discharging (The charging or discharging of the battery depends on the work mode.) default:00:00; range: 00:00~23:59
  - » **Allowed Disc Period End Time:** Time to stop discharging; default:23:59; range: 00:00~23:59



- **Char&Disc Period2:** The second time axis is closed by default, If two charging and discharging periods are needed, turn on the charging and discharging period 2. This period will hold the same setting logic as **Char&Disc Period**.

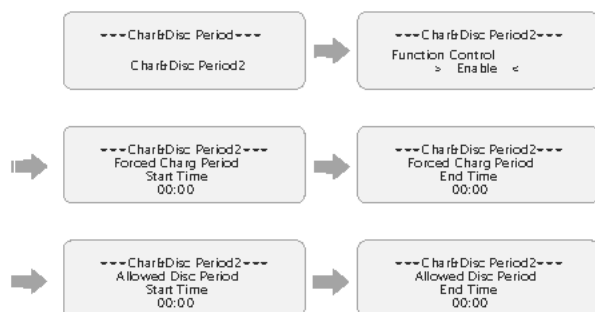

### Setting Peak shaving mode

- **DisChgPeriod1:** To set **ShavingStartTime**, **ShavingEndTime** and **PeakLimits**. **DisChgPeriod1** can be regarded as Peak shaving period. This period should be set to cover load peaks . Battery will be discharged to shave load peak until battery SOC drops to **Min SOC** (10% by default)

- » **PeakLimits1:** Default:0 W, range: 0-60000 W

Once the consumption (grid side) reaches this value, the inverter will start shaving to keep the consumption lower than this value.

- » **ShavingStartTime:** Default: 7:00

The battery starts discharging to shave consumption from the set time.

- » **ShavingEndTime:** Default: 15:00

The battery stops discharging at the set time.



- **DisChgPeriod2:** Same working logic with DisChgPeriod1

- » **PeakLimits2:** Default:0 W, range: 0-60000 W

- » **ShavingStartTime:** Default: 19:00

The battery starts discharging to shave consumption from the set time.

- » **ShavingEndTime:** Default: 23:00

The battery stops discharging at the set time.

- **ChargeFromGrid:** It can be used in specific time period. This period allows inverter to take energy from grid to charge battery in order to have enough backup for peak shaving. Please note that this period starts from ShavingEndTime2, end until ShavingStartTime1.

- » **Enable:** Activate the function of **ChargeFromGrid** to allow the inverter taking grid energy to charge battery. The **ChargePowerLimits** and **MAX\_SOC** will be displayed only when **ChargeFromGrid** is enabled.

- » **ChargePowerLimits:** Default: 1000 W; range: 0-60000 W

Settable target power taken from grid. Inverter will use this target power taken from grid to charge battery.

- » **MAX\_SOC:** Default: 50%; range: 10%-100%

Inverter will take grid energy to charge battery until battery SOC reaches this value.

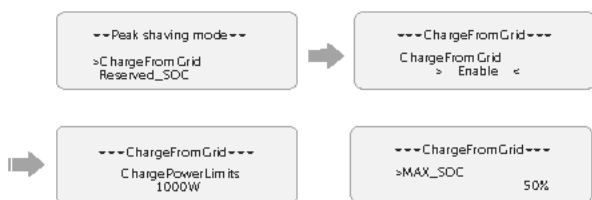

- **Reserved\_SOC**: Default: 50%; range: 10%-100%
  - » It can be used in specific time period. In this period, inverter does not allow taking grid energy to charge battery. PV is the only way to charge battery and PV will charge the battery first. Inverter will not supply power to loads until battery SOC higher than this value in order to save enough energy for later shaving period.



### Setting Load Management

To use the heat pump function, you need to set the relevant parameters on LCD screen. This function is applicable for the first generation of SolaX Adapter Box.

- a. Enter the **Load Management** interface through the path: **Menu>Setting>User Setting>Load Management**
- b. Set the **Load Management** mode. Overall three heat pump operation modes are available for you to choose:

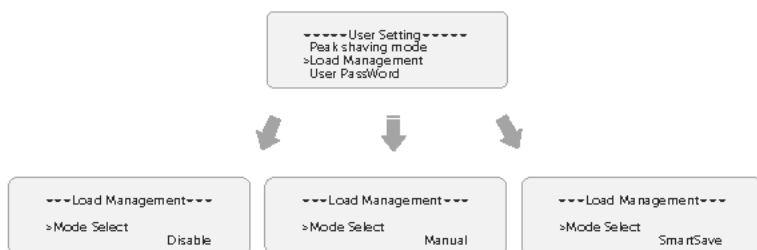

- » **Mode 1 Disable**: The Adapter Box function is disabled under this operation mode.
- » **Mode 2 Manual**: In this operating mode, you can change the Adapter Box from on to off, or from off to on through settings on the inverter or through SolaX App.
- » **Mode 3 SmartSave**: In this operating mode, users can set a series of parameters on the SolaX inverter to intelligently control how and when the heat pump works for them. (see Step C)

- c. Set the parameters for mode **SmartSave**. In this mode, you can set **Thresholds on Feedin power**, **Thresholds off Consumption**, **Thresholds off Battery SOC**, **Minimum duration per on-signal**, **Minimum duration per day** and **Schedule** in accordance with your actual needs.

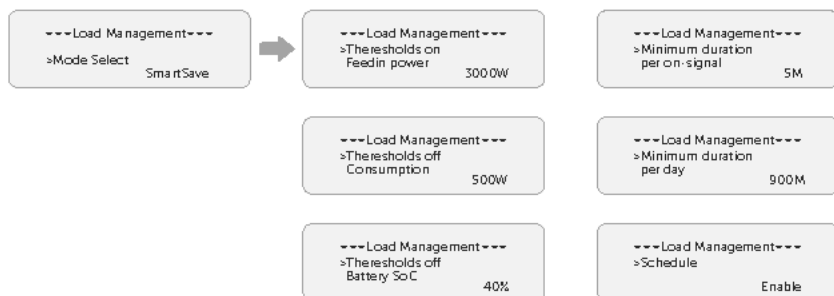

- Setting thresholds on/off
  - » **Thresholds on Feedin power:** Once the feed-in power is greater than or equal to the set value, the Adapter Box will turn on and the heat pump will heat the water up to a higher temperature.
  - » **Thresholds off Consumption:** Once the power consumption (from the grid) is greater than or equal to the set value, the Adapter Box will be turned off, SolaX system stops providing electricity to heat pump.
  - » **Thresholds off Battery SOC:** Once the battery SOC drops to the set value, the Adapter Box will turn off, SolaX system stops providing electricity to heat pump.
- Setting minimum / maximum duration
  - » **Minimum duration per on-signal:** Minimum working hours, heat pump will work at least the time set here every time it is activated. High priority than other power threshold settings.
  - » **Maximum duration per day:** Maximum working hour limitation per day. High priority than other power threshold settings.
- Setting schedule
  - » **Schedule:** Set the heat pump working periods flexibly (heat pump on and off periods). High priority than other power threshold settings. Two work periods can be set.

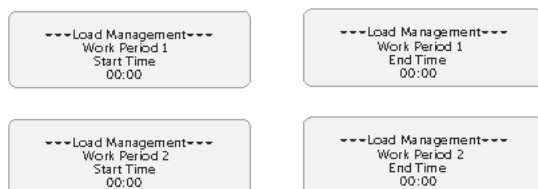

- Mode Priority: **Minimum/Maximum duration > Schedule >Thresholds on/off**

## Setting User Password

The default password is "0 0 0 0". You can reset the password here.

### 10.8.2 Advance Setting

Setting path: **Menu>Setting>Advance Setting**

#### NOTICE!

**Property losses or system damage due to unauthorized access to adjustable parameters.**

- All the adjustable parameters including safety code, grid parameter, export control, etc can be modified under the permissions of installer password. Unauthorized use of the installer password by unauthorized persons can lead to incorrect parameters being input, resulting in power generation loss or violation of local regulation. Get the installer password from the dealer and never open the password to unauthorized person.

## Setting Safety Code

#### NOTICE!

- The inverter cannot be connected to the grid before the safety code is correctly set. If there is any doubt about your safety code where the inverter installed, please consult your dealer or SolaX service for details.
- The setup will vary from different safety codes.

Here you can set safety code according to different countries and grid-tied standards.

There are several standards to choose from, please refer to the LCD screen on the inverter. (May be changed or added without notice)

- When you select safety code **CEI 0-21**, there will be additional **Self Test** option for setting under the path of **Menu>Setting>Advance Setting**.
- When you select safety code **AS4777**, there will be additional **AS4777 Setting** option for **General Control** and **Export Control** under the path of **Menu>Setting>Advance Setting**.

## Setting Grid parameters

The default value is the specified value under the current safety regulations. The contents will be displayed according to the requirements of local laws and regulations. Please refer to the actual contents displayed on the LCD screen on the inverter.

-----Grid Parameters-----  
 > Overvoltage  
 Undervoltage  
 OverFreq\_L1

Please select Australia Region A / B / C in compliance with AS4777. Only after the safety code setting is completed, some designated parameters in the inverter system will take effect according to the corresponding safety regulations.

Region	Australia A	Australia B	Australia C	New Zealand	
Standard Code Name	AS4777_2022_A	AS4777_2022_B	AS4777_2022_C	New Zealand	Setting Range
OV-G-V	265 V	265 V	265 V	265 V	230-300 V
OV-GV1-T	1.5 s	1.5 s	1.5 s	1.5 s	
OV-G-V2	275 V	275 V	275 V	275 V	230-300 V
OV-GV2-T	0.1 s	0.1 s	0.1 s	0.1 s	
UN-G-V1	180 V	180 V	180 V	180 V	40-230 V
UNGV1-T	10 s	10 s	10 s	10 s	
UN-G-V2	70 V	70 V	70 V	70 V	40-230 V
UNGV2-T	1.5 s	1.5 s	1.5 s	1.5 s	
OV-G-F1	52 Hz	52 Hz	55 Hz	55 Hz	50-55 Hz
OVGF1-T	0.1 s	0.1 s	0.1 s	0.1 s	
OV-G-F2	52HZ	52HZ	55HZ	55HZ	50-55 Hz
OVGF2-T	0.1 s	0.1 s	0.1 s	0.1 s	
UN-G-F1	47 Hz	47 Hz	45 Hz	45 Hz	40-50 Hz
UNGF1-T	1.5 s	1.5 s	5 s	1.5 s	
UN-G-F2	47 Hz	47 Hz	45 Hz	45 Hz	45-50 Hz
UNGF2-T	1.5 s	1.5 s	5 s	1.5 s	
Startup-T	60 s	60 s	60 s	60 s	15-1000 s
Restore-T	60 s	60 s	60 s	60 s	15-600 s

Region	Australia A	Australia B	Australia C	New Zealand	
Standard Code Name	AS4777_2022_A	AS4777_2022_B	AS4777_2022_C	New Zealand	Setting Range
Recover-VH	253 V	253 V	253 V	253 V	
Recover-VL	205 V	205 V	205 V	198 V	
Recover-FH	50.15 Hz	50.15 Hz	50.15 Hz	50.15 Hz	
Recover-FL	47.5 Hz	47.5 Hz	47.5 Hz	47.5 Hz	
Start-VH	253 V	253 V	253 V	253 V	
Start-VL	205 V	205 V	205 V	198 V	
Start-FH	50.15 Hz	50.15 Hz	50.15 Hz	50.15 Hz	
Start-FL	47.5 Hz	47.5 Hz	47.5 Hz	47.5 Hz	

## Setting Charger

The inverter is compatible with lithium-ion battery. You can set the charge & discharge parameters of battery.

- **Max Charge:** Maximum charging current of battery
- **Max Discharge:** Maximum discharging current of battery
- **Charger upper limit:** Default: 100%, range: 10%-100%.
  - » The maximum battery SOC when charging.

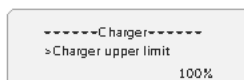
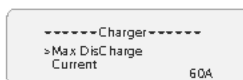
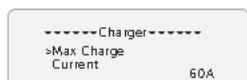

## Setting Export Control

This function allows the inverter to control the amount of electricity output to the grid. The **User Value** set here must be less than the maximum value. If the user does not want to supply power to the grid, set **User Value** to "0".

### NOTICE!

- Under Safety Code AS4777, **Export Control** is in the path of **Advance Setting> AS4777 Setting**. You can set the **Soft Limit** and **Hard Limit** of **Export Control** to control the power output to grid. Please refer to section "AS4777 Setting" for details.

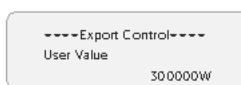

## Meter/CT Setting

CT or electricity meter is needed to connect with the inverter. Meter is set by default.

### NOTICE!

- If the user has other power generation equipment (such as inverter) at home and wants to monitor both, the inverter provides Meter2 communication function to monitor the power generation equipment.

- Select and enter the **Meter/CT Setting** according the setting path.
- Set the the address and direction of Meter/CT:
  - Case 1: Only CT is connected for the series inverter. No power generation equipment in the whole system. Please activate the CT selection. You can check the connection status in **Meter/CT Check**.



- Case 2: Only Meter 1 is connected for the series inverter. No power generation equipment in the whole system. Please activate the meter 1 selection and set the meter address and direction. You can check the connection status in **Meter/CT Check**.

### NOTICE!

- CT and meter 1 can not be used simultaneously.



- Case 3: CT and Meter 2 are connected. (CT for SolaX Hybrid inverter, Meter 2 for another power generation equipment or CT for another power generation equipment, Meter 2 for SolaX Hybrid inverter) For CT setting, please refer to Case 1. For meter 2 setting, please set the address and direction of Meter2 based on actual connection. You can check the connection status in **Meter/CT Check**.



- » Case 4: Meter 1 and Meter 2 are connected. (Meter1 for SolaX Hybrid inverter, Meter 2 for another power generation equipment or Meter 1 for another power generation equipment, Meter 2 for SolaX Hybrid inverter). Please refer to Case 2 for Meter 1 setting and Case 3 for Meter 2 setting. You can check the connection status in **Meter/CT Check**.

### Setting Self Test (only for CEI 0-21)

The self test function allows users to test the following items: **Full Test**, **Ovp(59.S2) test**, **Uvp (s1) test**, **Uvp (27. s2) test**, **Ofp (81> .S1) test**, **Ufp (81 <.S1) test**, **Ufp (81> .S2) test**, **Ufp (81 <.S2) test**, **Ovp10 (59. s1) test**.

In the **Self Test** interface, the user can select **All Test** or a single test item for testing. All tests take about 6 minutes. And it will display **Success**. For a single test item, it takes about a few seconds or minutes.

Before testing, make sure that the inverter is connected to the grid. Click **Test Report** to view the test results of all items.

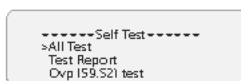

### Setting GMPPT

You can set the shadow tracking speed with four options, which are **Off**, **Low**, **Middle**, and **High**. This function is off by default.

- **Off**: Switch off the shadow tracking function.
- **Low**: Scan the shadow every four hours.
- **Middle**: Scan the shadow every three hours.
- **High**: Scan the shadow per hour.



### Setting Modbus

You can set the address and select the baud rate of the external communication protocol for communicating with external equipment.



## Setting External ATS

External ATS function is used to achieve automatic switching from grid connection mode to off grid mode or from off grid mode to grid connection model by using external ATS equipment. The function is disabled by default. When the X3-PBOX-150K G2 is connected in the parallel system, please enable the function.

- **Enable:** on/off-grid switching by external equipment.
- **Disable:** inverter internal on/off-grid switching.



## Setting Power Factor

The default value is the specified value under the current safety regulations. The contents will be displayed according to the requirements of local laws and regulations. Please refer to local grid requirements.

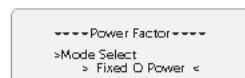
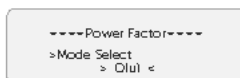
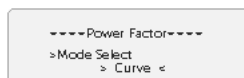
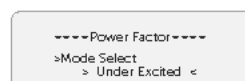
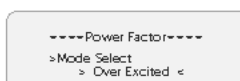
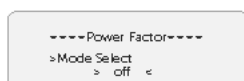

Operation on LCD

Off	
Over Excited	PF Value
Under Excited	PF Value
Curve	P1 PF
	P2 PF
	P3 PF
	P4 PF
	Power 1
	Power 2
	Power 3
	Power 4
	PflockInPoint
	PflockOutPoint
Q(u)	3Tua
	SetQuPower1
	SetQuPower2
	SetQuPower3
	SetQuPower4
	QuRespondV1
	QuRespondV2
	QuRespondV3
	QuRespondV4
	K
3Tua	
QuDelayTimer	
QuLockEn	
Fixed Q Power	Q Power

- Reactive power control, reactive power standard curve  $\cos \varnothing = f(P)$ 
  - » For VDE ARN 4105, the curve  $\cos \varnothing = f(P)$  should refer to curve A. The set default value is shown in curve A.
  - » For TOR, the curve  $\cos \varnothing = f(P)$  should be curve B. The set default value is shown in curve B.
  - » For CEI 0-21, the default value of PFLockInPoint is 1.05. When  $V_{ac} > 1.05V_n, P_{ac} > 0.2 P_n$ , curve  $\cos \varnothing = f(P)$  corresponds to curve C.

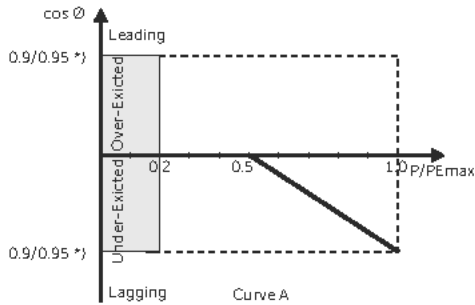

- » \*) If the inverter  $P_{max} \leq 4.6kW$ , the Power Factor is 0.95 at 1.0 power; if the inverter  $P_{max} > 4.6kW$ , the Power Factor is 0.90 at 1.0 power.

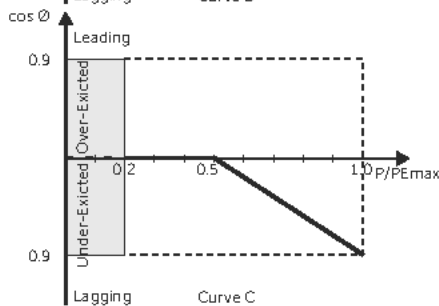
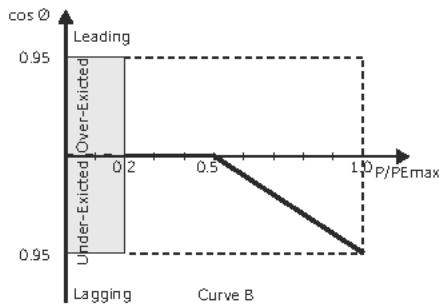

- » \*) Depend on the required Q capacity

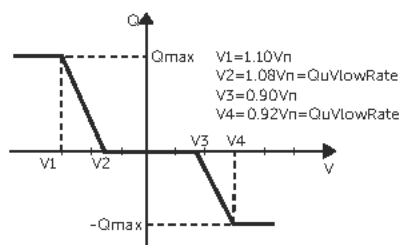

### Setting Pu Function

(Applicable to specific countries, please refer to local grid requirements.)

The PU function is a volt-watt response mode required by certain national standards such as AS 4777. This function can control the active power of the inverter according to the grid voltage. You can set **Response Voltage**, **3Tau**, **PuPower**, **3Tau\_Charge** and **Pu Type**.



### Setting FVRT function

FVRT consists of HVRT (High Voltage Ride Through) and LVRT (Low Voltage Ride Through). With FVRT function, the series inverter can ensure continuous operation without disconnecting from the grid within a certain range of voltage sudden rise and drop in a certain time interval.

- **Enable:** Enable the FVRT function
- **VacUpper:** The voltage for high voltage ride through
- **VacLower:** The voltage for low voltage ride through

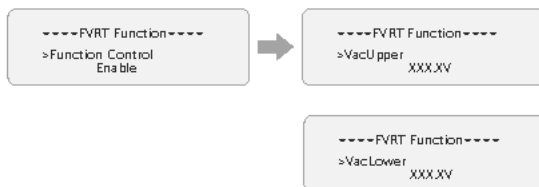

## Setting Power Limit

Here you can set the rated output power by percentage.

The percentage of rated output power is used as the actual output power.

**Proportion:** Default: 1.00; range: 0.00~1.10

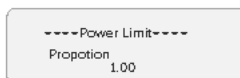

## Setting DRM function (Applicable to AS4777)

The DRM Function is a demand response method required by the AS4777 standard and is only applicable to Australia and New Zealand.

The function is enabled by default.

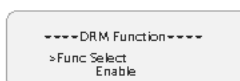

## Setting Parallel Connection

In parallel system, there are three status: **Free**, **Slave** and **Master**.

Free	Only if no one inverter is set as a <b>Master</b> , all inverters are in free mode in the system.
Slave	Once one inverter is set as a <b>Master</b> , all other inverters will enter slave mode automatically. Slave mode can not be changed from other modes by LCD setting.
Master	When one inverter is set as a <b>Master</b> , this inverter enters master mode. Master mode can be changed to free mode.

### NOTICE!

- Refer to section "8.6.2 Parallel Connection" for specific parallel connection diagram.

NOTICE!

- Master inverter has an absolute lead in the parallel system to control all slave inverter's energy management and dispatch control. Once master inverter has some error and stop working, all slave inverter will be stop simultaneously. But master inverter is independent of all slave inverter to work and will not be affected by slave inverter's fault.
- Overall system will be running according to master inverter's setting parameters, and most setting parameters of slave inverter will be kept but not be cancelled.
- Once slave inverter exits from system and be running as an independent unit (the network cable is disconnected simultaneously), its all setting will be re-activated.

How to build the parallel connection

- Turn on the power of the entire system, find the inverter connected to the meter, enter the setting page of the inverter LCD screen, select the Parallel Setting, and select **Master**; then enter the **Resistance Switch** and set it to **ON**;



- Find the last slave in the parallel system and enter the setting page of the inverter LCD screen and set the **Resistance Switch** to **ON**.

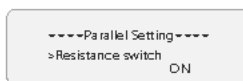

How to remove the parallel connection

- Select the **Parallel Settings** and select **Free** for Master and slave inverter.



- Disconnect all the network cables on the Parallel-1 and Parallel-2 port.

NOTICE!

- If a slave inverter is set to **Free** mode but not disconnect the network cable, this inverter will return to **Slave** mode automatically.
- If a slave inverter is disconnected with master inverter but not be set to **Free** mode, this slave inverter will stop working and prompt **ParallelFault**.

## Setting Main Breaker Limit

Due to power limit, the current of Meter or CT must be abide by the utility's requirements. You can set the corresponding amperage according to the utility's requirements. Failure to set the current may cause a circuit breaker fault of main switchboard, thus affecting the charging and discharging of battery.

The default value is 100 A, range: 10-250 A

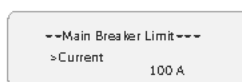

## Setting Phase Unbalanced

This function controls the distribution of AC output power. **Disable** is the default setting .

- **Enable** mode: If 60 kW AC power can be exported, each phase power will be divided as below according to different loads connected with each phase.

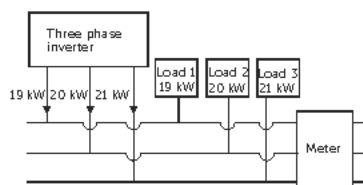

- **Disable** mode: If 60 kW AC power can be exported, each phase power will be divided equally as below and it is unrelated with the loads connected with each phase.

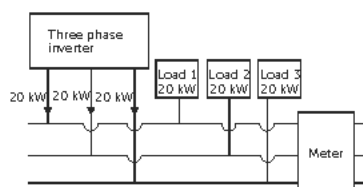

## EPS Setting

Select and enter **EPS Setting** interface and set **Frequency**, **Min SOC**, **Min ESC SOC**, **Super-Backup** and **EPSVoltChange**.

- **Frequency**: Default: 50Hz. Output frequency of EPS
- **Min SOC**: Default: 10%, range: 10%-100%
  - » If the battery SOC is lower than the Min SOC set in the inverter, the battery will not discharge the power to the load. The inverter will enter EPS waiting

mode waiting for battery to be charged.

- **Min ESC SoC:** Default: 30%, range: 15%-100%
  - » The minimum SOC to enter EPS mode. When the battery SOC reaches the Min ESC SOC, the inverter will automatically enter EPS mode from EPS Waiting mode.

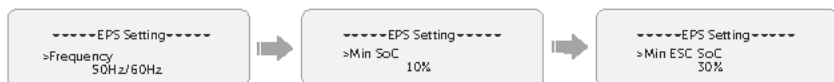

- To enable the “**Super-Backup**” mode and allow only PV without battery to enter EPS. **Disable** is the default setting.

### AS4777 Setting

The function of AS4777 Setting is only activated when the Safe Code is set to AS4777 and New Zealand, which is only applicable to Australia and New Zealand.

- Select and enter **AS4777 Setting** in **Advance Setting** interface . You will see **Export Control** (for active power output control) and **General Control** (for apparent power output control).

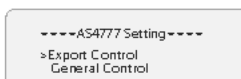

- Set the **Soft Limit** value and **Hard Limit** value for Export Control and General Control. The figure below will take the setup of Export Control as an example.

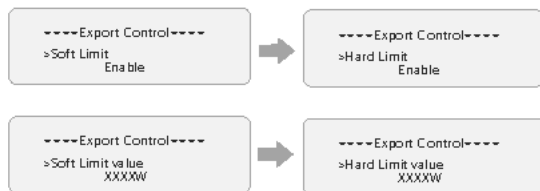

#### NOTICE!

- **Soft Limit:** Control the output value to grid within the set **Soft Limit Value**.
- **Hard Limit:** If the actual output value reaches the set **Hard Limit Value**, the system will automatically disconnect from grid and prompt error message on the LCD.

### Setting ExternalGen

Two modes are available for you to choose according to actual needs when connecting generator: i.e. ATS Control and Dry Contact.

## How to make connection with generator through ATS control

- a. Select and enter **ExternalGen** interface and select **ATS Control**.

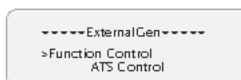

- b. You can set the relative parameters as below in accordance with actual needs.
- » **MaxChargePower**: Maximum battery charging power from generator. (0-30000 W, 5000W by default)

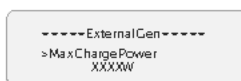

- » **Char&Disc Period**: Including **Forced Charge Period** and **Allowed Disc Period**. Two periods can be set. These period settings are associated with the same settings under **Work Mode** for no need to jump to work mode page to set the working period when using generator mode.

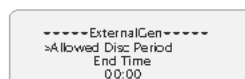
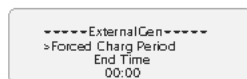
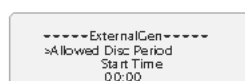
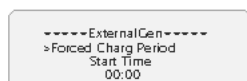

- » **Charge from Gen and Charge battery to**: The SOC which allows the system charging from generator. (10-100%, 10% by default)

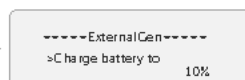
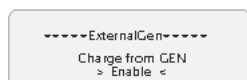

## How to make connection with generator through Dry Contact

- a. Select and enter **ExternalGen** interface and select **Dry Contact**.

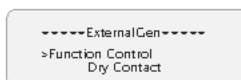

- b. Set the relative parameters in accordance with actual needs.

- » **MaxChargePower**: Maximum battery charging power from generator. (0-30000 W, 5000W by default).

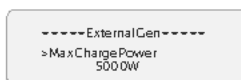

- » **Start Gen Method:** **Reference SOC** and **Immediately** can be selected.  
**Reference SOC:** Turn on/off generator according to the set SOC.  
**Immediately:** Turn on /off the generator when grid status changed.

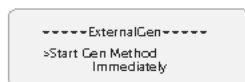
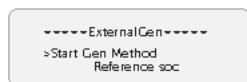

- » **Switch on/off SOC:** the option is activated when you select **Reference SOC** for **Start Gen Method**. Inverter will turn on the generator when the battery reaches the set **Switch on SOC** and turn it off when the battery reaches the set **Switch off SOC**.

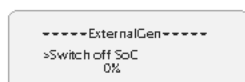
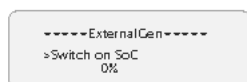

- » **MaxRunTime:** Maximum operating time of generator. (30 Min by default)

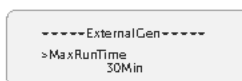

- » **MinRestTime:** Minimum time interval for two consecutive starts to avoid frequent generator switching ON/OFF.

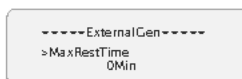

- » **Char&Disc Period:** Including **Forced Charge Period** and **Allowed Disc Period**. Two periods can be set. These period settings are associated with the same settings under **Work Mode** for no need to jump to work mode page to set the working period when using generator mode.

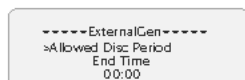
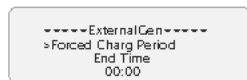
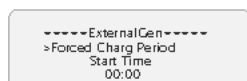

- » **Allow Work:** Allowed time period for generator operating. You can set the start time and end time.

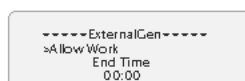
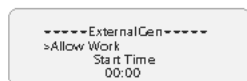

- » **Charge from Gen and Charge battery to:** The SOC which allows the system charging from generator. (10-100 W from generator, 10% by default)



## Reset

Here you can reset value of Error Log, Meter/CT, INV Energy and Wifi; and restore to the factory set.

- **Reset Error Log**



- **Reset Meter/CT**



- **Reset INV Energy**



- **Reset Wifi**



- **Factory Reset**



## Setting Battery Heating

This function is disabled by default and is only valid when the battery has the heating function. You can enable **Battery Heating** function to make the battery heated. And set the heating period.

- Enable the **Battery Heating** function.



- b. Set the heating start time and end time for the battery. Two heating periods can be set.

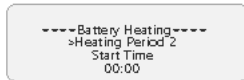
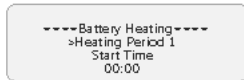

### Setting Extend BAT FUNC

This function allows for the extension of battery modules, such as adding a new battery module to an existing system. It is only applicable and functional in on-grid mode and cannot be used in EPS mode. In on-grid mode, enabling this function will make the inverter to charge or discharge the battery SOC to approximately 38%. This function will turn to **Disable** automatically after 48 hours this function enabled..

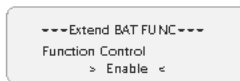

### Setting HotStandby Setting

This function is mainly to reduce the energy losses of the system. when the power of load is extremely low and there is no sufficient PV input voltage, or when the battery SOC is less than or equal to 10% and there is no sufficient PV input voltage, the inverter will enter "HotStandby" status. When the power of loads is higher than 150 W, or there is sufficient PV input voltage, or the battery is forced charged, the inverter will exit "HotStandby" status.

It is disabled by default.

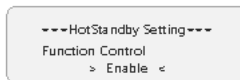

### Setting Pgrid Bias

This function is disabled by default.

For the country with zero export limit:

- a. Check the **Meter/CT** value in **Menu>System Status>Meter/CT** when the function is disabled.

- b. If the **Meter/CT** displayed in **System Status** is negative value, please select **Grid** for **Pgrid Bias** to discharge power to the mains. If the **Meter/CT** displayed in **System Status** is positive value, please select **INV** for **Pgrid Bias** to take power from the mains.



## Setting Internal485

You can communicate with other SolaX equipment, such EV Charger, Datahub and Adapter Box G2 through **Internal485**.

- Select and enter **Internal485** interface;
- Select the equipment which needs to be connected and set the corresponding Baud Rate and Address. Take EV Charger as an example.

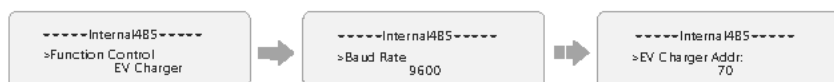

### NOTICE!

- When two equipments need to be connected at the same time, the baud rate and address of the two equipments shall be set to the same.

- Check the connecting status. For the connection status of Datahub, please check it on the Datahub.



### NOTICE!

- Please refer to "8.6.4 RS485 Communication Connection" for specific wiring connection of Datahub, EV Charger and Adapter Box.

## Battery Charge EVC

You can set **Enable** to allow the battery to discharge energy to EV Charger. When you set to **Disable**, battery discharging energy to EV Charger is not allowed.

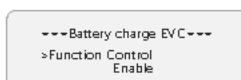

## Advance Password

You can reset the advanced password here.

## 10.9 About

Displaying path: **Menu > About**

Here shows the basic information of the inverter, battery and internal code. After entering the **About** interface, you can check those information.

- Inverter
  - » Inverter SN, Register SN, ARM Verion, DSP version, On-grid Runtime, EPS Runtime
- Battery1 and Battery2
  - » BatBrand, Bat\_M SN (SN of BMS), Bat\_PS1 SN (SN of battery module 1), Bat\_PS2 SN (SN of battery module 2), Bat\_PS3 SN (SN of battery module 3), Bat\_PS4 SN (SN of battery module 4), Battery M Version (software version of BMS) and Battery S version (software version of battery module).
- Internal Code
  - » Internal code of inverter, battery1 and battery2

# 11 Troubleshooting and Maintenance

## 11.1 Power off

- Set **OFF** in the **System ON/OFF** on the inverter LCD screen.
- Turn off the inverter system button.
- Turn off the AC breakers between the inverter and the power grid.
- Set the DC switch1 and DC switch2 to "OFF".
- Switch off the battery or the breaker, button, DC switch of the battery (see documentation of the battery manufacturer).

### ⚠ WARNING!

- After the inverter powers off, there will still be the remaining electricity and heat which may cause electric shocks and body burns. Please wear personal protective equipment (PPE) and begin servicing the inverter five minutes after power off.

## 11.2 Operation of Lockable DC Switch (for Australia Version Only)

### NOTICE!

- The Australian version DC switch is a lockable DC switch to prevent accidental switching on during maintenance, the lock needs to be prepared by the user.

The lockable DC switch includes 3 states: ON, OFF, and OFF+Lock. The DC switch is in the OFF state by default.

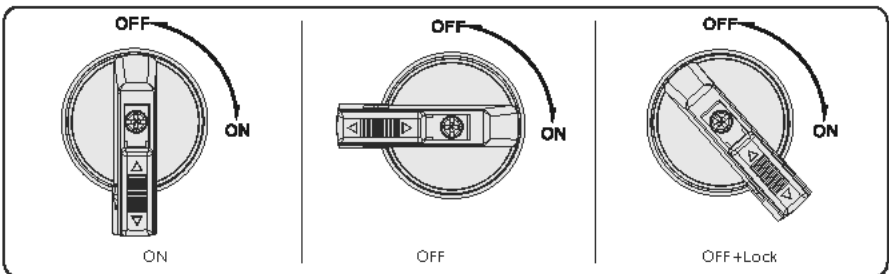

- Turn on the DC switch: rotate the DC switch from OFF state to ON state.

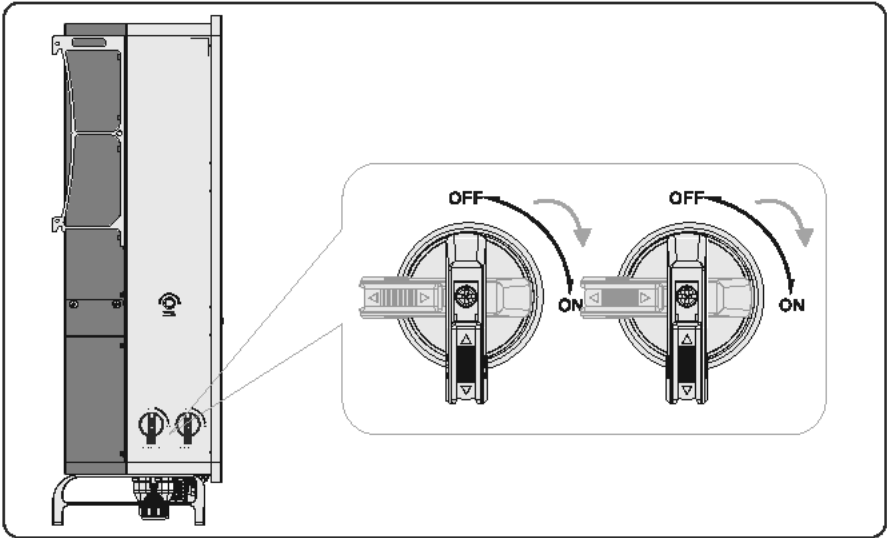

- Turn off the DC switch: rotate the DC switch from ON state to OFF state.

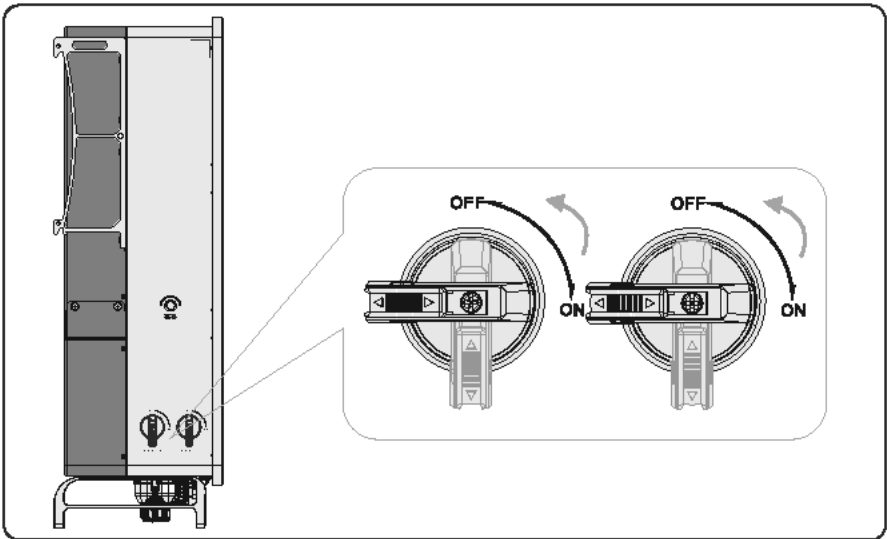

- Lock the DC switch
  - a. Rotate the DC switch to OFF state, then rotate the DC switch to the left side;
  - b. Push the position indicated by the arrow upward (as shown in the diagram below).
  - c. (Optional) After pushing the position upward, choose to lock the DC switch with a lock.

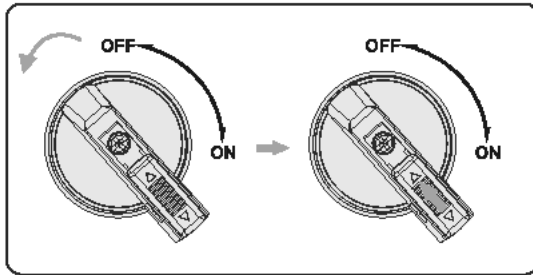

- Unlock the DC switch
  - a. Remove the lock. (If any);
  - b. Push the position indicated by the arrow down (as shown in the diagram below);
  - c. Wait for it to return to OFF state.

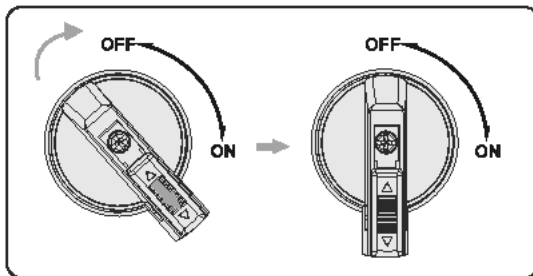

### 11.3 Troubleshooting

This section contains information and procedures for resolving possible problems with the inverter, and provides the troubleshooting tips to identify and solve most problems that may occur. Please check the warning or fault information on the system control panel or on the App and read the suggested solutions below when error occurs. Contact SolaX Customer Service for further assistance. Please be prepared to describe the details of your system installation and provide the model and serial number of the inverter.

Error Code	Fault	Descriptions and Diagnosis
IE 01	TZ Protect Fault	<p>Overcurrent fault.</p> <ul style="list-style-type: none"> <li>• Wait for a while to check if it returns to normal.</li> <li>• Disconnect PV+ PV- and batteries, reconnect.</li> <li>• If the system is in off-grid state, check if the power of EPS loads exceeds the maximum limit of the system or exceeds the current power supply of battery.</li> <li>• If the system fails to restore to its normal state, please contact SolaX for help.</li> </ul>
IE 02	Grid Lost Fault	<p>Grid Lost Fault</p> <ul style="list-style-type: none"> <li>• Check the grid connection status</li> <li>• Or contact SolaX for help.</li> </ul>
IE 03	Grid Volt Fault	<p>Power grid voltage overrun</p> <ul style="list-style-type: none"> <li>• Wait a moment, if the utility returns to normal, the system will reconnect.</li> <li>• Please check if the grid voltage is within normal range.</li> <li>• Or contact SolaX for help.</li> </ul>
IE 04	Grid Freq Fault	<p>Grid overfrequency</p> <ul style="list-style-type: none"> <li>• Wait a moment, If the utility returns to normal, the system reconnects.</li> <li>• Or contact SolaX for help.</li> </ul>
IE 05	PV Volt Fault	<p>PV overvoltage</p> <ul style="list-style-type: none"> <li>• Check the output voltage of the PV panel.</li> <li>• Check if the DC switch is OFF.</li> <li>• Or contact SolaX for help.</li> </ul>
IE 06	Bus Volt Fault	<ul style="list-style-type: none"> <li>• Press the <b>ESC</b> key to restart the inverter.</li> <li>• Check if the PV input open circuit voltage is in the normal range.</li> <li>• Check if the power of half-wave load exceeds the system limit.</li> <li>• Or contact SolaX for help.</li> </ul>

Error Code	Fault	Descriptions and Diagnosis
IE 07	Bat Volt Fault	<p>Battery voltage fault</p> <ul style="list-style-type: none"> <li>Check if the battery input voltage is within normal range</li> <li>Or contact SolaX for help.</li> </ul>
IE 08	AC10mins Volt	<p>Grid voltage out of range in the last 10 minutes.</p> <ul style="list-style-type: none"> <li>The system will return to normal if the grid returns to normal.</li> <li>Or contact SolaX for help.</li> </ul>
IE 09	DCI OCP Fault	<p>DCI overcurrent protection fault.</p> <ul style="list-style-type: none"> <li>Wait for a while to check if it's back to normal.</li> <li>Or contact SolaX for help.</li> </ul>
IE 10	DCV OVP Fault	<p>DCV EPS(Off-grid) overvoltage protection fault.</p> <ul style="list-style-type: none"> <li>Wait for a while to check if it's back to normal.</li> <li>Or contact SolaX for help.</li> </ul>
IE 11	SW OCP Fault	<p>Software detection of overcurrent Fault.</p> <ul style="list-style-type: none"> <li>Wait for a while to check if it's back to normal.</li> <li>Shut down photovoltaic, battery and grid connections.</li> <li>Or contact SolaX for help.</li> </ul>
IE 12	RC OCP Fault	<p>Overcurrent protection fault.</p> <ul style="list-style-type: none"> <li>Check the impedance of DC input and AC output.</li> <li>Wait for a while to check if it's back to normal.</li> <li>Or contact SolaX for help.</li> </ul>
IE 13	Isolation Fault	<p>Insulation fault</p> <ul style="list-style-type: none"> <li>Please check the wire insulation for damage.</li> <li>Wait for a while to check if it's back to normal.</li> <li>Or contact SolaX for help.</li> </ul>
IE 14	Temp Over Fault	<p>Temperature out of range</p> <ul style="list-style-type: none"> <li>Check if the ambient temperature exceeds the limit.</li> <li>Or contact SolaX for help.</li> </ul>
IE 15	Bat Con Dir Fault	<ul style="list-style-type: none"> <li>Battery direction fault</li> <li>Check if the battery lines are connected in the opposite direction.</li> <li>Or ask for help from the installer if it can not return to normal.</li> </ul>
IE 16	EPS Overload	<p>EPS(Off-grid) overload fault</p> <ul style="list-style-type: none"> <li>Shutdown the high-power device and press the <b>ESC</b> key to restart the inverter.</li> <li>Or contact SolaX for help if it can not return to normal.</li> </ul>

Error Code	Fault	Descriptions and Diagnosis
IE 17	Overload Fault	<p>On-grid mode overload fault</p> <ul style="list-style-type: none"> <li>• Shutdown the high-power device and press the <b>ESC</b> key to restart the inverter.</li> <li>• Or contact SolaX for help if it can not return to normal.</li> </ul>
IE 18	BatPowerLow	<p>Bat Power Low</p> <ul style="list-style-type: none"> <li>• Shutdown the high-power device and press the <b>ESC</b> key to restart the inverter.</li> <li>• Please charge the battery to a level higher than the protection capacity or protection voltage.</li> </ul>
IE 19	BMS Lost	<p>Battery communication lost</p> <ul style="list-style-type: none"> <li>• Check that the communication cable between the battery and the inverter are properly connected.</li> <li>• Or contact SolaX for help if it can not return to normal.</li> </ul>
IE 20	Fan Fault	<p>Fan Fault</p> <ul style="list-style-type: none"> <li>• Check for any foreign matter that may have caused the fan not to function properly.</li> <li>• Or contact SolaX for help if it can not return to normal.</li> </ul>
IE 21	Low TempFault	<p>Low temperature fault.</p> <ul style="list-style-type: none"> <li>• Check if the ambient temperature is too low.</li> <li>• Or contact SolaX for help if it can not return to normal.</li> </ul>
IE 25	InterComFault	<p>Inter_Com_Fault</p> <ul style="list-style-type: none"> <li>• Restart the inverter.</li> <li>• Or contact SolaX for help if it can not return to normal.</li> </ul>
IE 26	INV EEPROM	<p>Inverter EEPROM Fault.</p> <ul style="list-style-type: none"> <li>• Shut down photovoltaic, battery and grid, reconnect.</li> <li>• Or contact SolaX for help if it can not return to normal.</li> </ul>
IE 27	RCD Fault	<p>Residual Current Device fault</p> <ul style="list-style-type: none"> <li>• Check the impedance of DC input and AC output.</li> <li>• Disconnect PV + PV - and batteries, reconnect.</li> <li>• Or contact SolaX for help if it can not return to normal.</li> </ul>
IE 28	Grid Relay Fault	<p>Electrical relay fault</p> <ul style="list-style-type: none"> <li>• Disconnect PV+ PV- grid and batteries and reconnect.</li> <li>• Or contact SolaX for help if it can not return to normal.</li> </ul>

Error Code	Fault	Descriptions and Diagnosis
IE 29	EPS Relay	<p>EPS(Off-grid) relay fault</p> <ul style="list-style-type: none"> <li>• Disconnect PV+ ,PV- , grid and batteries and reconnect.</li> <li>• Or contact SolaX for help if it can not return to normal.</li> </ul>
IE 30	PV ConnDirFault	<p>PV direction fault</p> <ul style="list-style-type: none"> <li>• Check if the PV input lines are connected in the opposite direction.</li> <li>• Or contact SolaX for help if it can not return to normal.</li> </ul>
IE 31	Battery Relay	<p>Charge relay fault</p> <ul style="list-style-type: none"> <li>• Press the <b>ESC</b> key to restart the inverter.</li> <li>• Or contact SolaX for help if it can not return to normal.</li> </ul>
IE 32	Earth Relay	<p>EPS(Off-grid) earth relay fault</p> <ul style="list-style-type: none"> <li>• Press the <b>ESC</b> key to restart the inverter.</li> <li>• Or contact SolaX for help if it can not return to normal.</li> </ul>
IE 100	PowerTypeFault	<p>Power type fault</p> <ul style="list-style-type: none"> <li>• Upgrade the software and press the <b>ESC</b> key to restart the inverter.</li> <li>• Or contact SolaX for help if it can not return to normal.</li> </ul>
IE 102	Mgr EEPROM Fault	<p>Mgr E2prom Error.</p> <ul style="list-style-type: none"> <li>• Shut down photovoltaic ,battery and grid, and then reconnect.</li> <li>• Or contact SolaX for help if it can not return to normal.</li> </ul>
IE 103	Fan4 Fault	<p>FAN4 Fault</p> <ul style="list-style-type: none"> <li>• Check if the foreign objects stuck in the fan.</li> <li>• Or contact SolaX for help.</li> </ul>
IE 104	NTC Sample Invalid	<p>NTC Sample Fault</p> <ul style="list-style-type: none"> <li>• Make sure the NTC is properly connected and the NTC is in good condition.</li> <li>• Please confirm that the installation environment is normal</li> <li>• Or contact SolaX for help if it can not return to normal.</li> </ul>

Error Code	Fault	Descriptions and Diagnosis
IE 107	CT Fault	<p>CT Fault</p> <ul style="list-style-type: none"> <li>Check if the CT is working properly</li> <li>Or contact SolaX for help if it can not return to normal.</li> </ul>
IE 109	Meter Fault	<p>Meter Fault</p> <ul style="list-style-type: none"> <li>Check if the meter is working properly</li> <li>Or contact SolaX for help if it can not return to normal.</li> </ul>
IE 110	BypassRelayFlt	<p>Bypass Relay Fault</p> <ul style="list-style-type: none"> <li>Press the <b>ESC</b> key to restart the inverter.</li> <li>Or contact SolaX for help if it can not return to normal.</li> </ul>
IE 111	FAN3 Fault	<p>FAN3 Fault</p> <ul style="list-style-type: none"> <li>Check if the foreign objects stuck in the fan.</li> <li>Or contact SolaX for help.</li> </ul>
IE 112	ARMParaComFlt	<p>ARM Parameter Communication fault</p> <ul style="list-style-type: none"> <li>Check that the communication cables of inverters are well connected and the baud rate of COMM setting of inverters are the same.</li> <li>Or contact SolaX for help if it can not return to normal.</li> </ul>
IE 113	FAN1 Fault	<p>FAN1 Fault</p> <ul style="list-style-type: none"> <li>Check if the foreign objects stuck in the fan.</li> <li>Or contact SolaX for help.</li> </ul>
IE 114	FAN2 Fault	<p>FAN2 Fault</p> <ul style="list-style-type: none"> <li>Check if the foreign objects stuck in the fan.</li> <li>Or contact SolaX for help.</li> </ul>
IE 115	20305Com Fault	<p>Com Fault</p> <ul style="list-style-type: none"> <li>Check the connection of the monitoring module, reinsert the module.</li> <li>Please contact SolaX for help.</li> </ul>
BE 01	BMS1_UCellOver BMS2_UCellOver	<p>Battery Error - Cell Overvoltage Fault</p> <ul style="list-style-type: none"> <li>Please contact SolaX for help.</li> </ul>
BE 02	BMS1_UCellLow BMS2_UCellLow	<p>Battery Error - Cell Undervoltage Fault</p> <ul style="list-style-type: none"> <li>Please contact SolaX for help.</li> </ul>
BE 03	BMS1_UCellDiff BMS2_UCellDiff	<p>Battery Error - Large Cell Differential Pressure Fault</p> <ul style="list-style-type: none"> <li>Please contact SolaX for help.</li> </ul>

Error Code	Fault	Descriptions and Diagnosis
BE 04	BMS1_HVBOVer	Battery Error - Total Voltage Overvoltage Fault <ul style="list-style-type: none"> <li>• Please contact SolaX for help.</li> </ul>
	BMS2_HVBOVer	
BE 05	BMS1_HVBLow	Battery Error - Total Voltage Undervoltage Fault <ul style="list-style-type: none"> <li>• Please contact SolaX for help.</li> </ul>
	BMS2_HVBLow	
BE 06	BMS1_TempOver	Over temperature in battery system <ul style="list-style-type: none"> <li>• Please contact SolaX for help.</li> </ul>
	BMS2_TempOver	
BE 07	BMS1_SelfCheck	Self check fault in battery system <ul style="list-style-type: none"> <li>• Please contact SolaX for help.</li> </ul>
	BMS2_SelfCheck	
BE 08	BMS1_PoRlyAdh	Battery Error - Main Positive Relay Adhesion Fault <ul style="list-style-type: none"> <li>• Please contact SolaX for help.</li> </ul>
	BMS2_PoRlyAdh	
BE 09	BMS1_PoRlyOpen	Battery Error - Main Positive Open Relay Fault <ul style="list-style-type: none"> <li>• Please contact SolaX for help.</li> </ul>
	BMS2_PoRlyOpen	
BE 10	BMS1_NeRlyAdh	Battery Error - Main Negative Relay Adhesion Fault <ul style="list-style-type: none"> <li>• Please contact SolaX for help.</li> </ul>
	BMS2_NeRlyAdh	
BE 11	BMS1_NeRlyOpen	Battery Error - Main Negative Open Relay Fault <ul style="list-style-type: none"> <li>• Please contact SolaX for help.</li> </ul>
	BMS2_NeRlyOpen	
BE 12	BMS1_PreChgFail	Battery Error - Battery Precharge Fault <ul style="list-style-type: none"> <li>• Please contact SolaX for help.</li> </ul>
	BMS2_PreChgFail	
BE 13	BMS1_CellSample	Battery Error - Battery Cell Sampling Fault <ul style="list-style-type: none"> <li>• Please contact SolaX for help.</li> </ul>
	BMS2_CellSample	
BE 14	BMS1_TempSample	Battery Error - Battery Temperature Sampling Fault <ul style="list-style-type: none"> <li>• Please contact SolaX for help.</li> </ul>
	BMS2_TempSample	
BE 15	BMS1_Sys	Battery Error - Battery System Fault <ul style="list-style-type: none"> <li>• Please contact SolaX for help.</li> </ul>
	BMS2_Sys	
BE 16	BMS1_DsgOver	Battery Error - Battery Discharge Overcurrent Fault <ul style="list-style-type: none"> <li>• Please contact SolaX for help.</li> </ul>
	BMS2_DsgOver	
BE 17	BMS1_ChgOver	Battery Error - Battery Charge Overcurrent Fault <ul style="list-style-type: none"> <li>• Please contact SolaX for help.</li> </ul>
	BMS2_ChgOver	

Error Code	Fault	Descriptions and Diagnosis
BE 18	BMS1_AFCom	Battery Error - Battery AFE communication Fault <ul style="list-style-type: none"> <li>• Please contact SolaX for help.</li> </ul>
	BMS2_AFCom	
BE 19	BMS1_InvCom	Battery Error - Extranet Communication Fault <ul style="list-style-type: none"> <li>• Please contact SolaX for help.</li> </ul>
	BMS2_InvCom	
BE 20	BMS1_MidCom	Battery Error - Intermediate Network Communication Fault <ul style="list-style-type: none"> <li>• Please contact SolaX for help.</li> </ul>
	BMS2_MidCom	
BE 21	BMS1_VoltSensor	Battery Error - Voltage Sensor Fault <ul style="list-style-type: none"> <li>• Please contact SolaX for help.</li> </ul>
	BMS2_VoltSensor	
BE 22	BMS1_IDRepet	Battery Error - Repetitive ID Fault <ul style="list-style-type: none"> <li>• Please contact SolaX for help.</li> </ul>
	BMS2_IDRepet	
BE 23	BMS1_TempLow	Battery Error - Low Temperature Fault <ul style="list-style-type: none"> <li>• Please contact SolaX for help.</li> </ul>
	BMS2_TempLow	
BE 24	BMS1_CurrSensor	Battery Error - Current Sensor Fault <ul style="list-style-type: none"> <li>• Please contact SolaX for help.</li> </ul>
	BMS2_CurrSensor	
BE 25	BMS1_Line	Battery Error - Open Power Cable Fault <ul style="list-style-type: none"> <li>• Please contact SolaX for help.</li> </ul>
	BMS2_Line	
BE 26	BMS1_Flash	Battery Error - Flash Fault <ul style="list-style-type: none"> <li>• Please contact SolaX for help.</li> </ul>
	BMS2_Flash	
BE 27	BMS1_AFEProtect	Battery Error - AFE Self-protection Fault <ul style="list-style-type: none"> <li>• Please contact SolaX for help.</li> </ul>
	BMS2_AFEProtect	
BE 28	BMS1_ChgReq	Battery Error - Charge Request Fault <ul style="list-style-type: none"> <li>• Please contact SolaX for help.</li> </ul>
	BMS2_ChgReq	
BE 29	BMS1_Ins	Battery Error - Battery Insulation Fault <ul style="list-style-type: none"> <li>• Check that the battery is properly grounded and restart the battery.</li> <li>• Please contact SolaX for help.</li> </ul>
	BMS2_Ins	
BE 30	BMS1_MCB	Battery Error - Micro Circuit Breaker Fault <ul style="list-style-type: none"> <li>• Please contact SolaX for help.</li> </ul>
	BMS2_MCB	
BE 31	BMS1_LinkTemp	Battery Error - Contactor Over Temperature Fault <ul style="list-style-type: none"> <li>• Please contact SolaX for help.</li> </ul>
	BMS2_LinkTemp	

Error Code	Fault	Descriptions and Diagnosis
BE 32	BMS1_BatLinker	Battery Error - Internal contact point Abnormally high in the battery <ul style="list-style-type: none"> <li>• Please contact SolaX for help.</li> </ul>
	BMS2_BatLinker	
BE 33	BMS1_Fan	Battery Error - Fan Fault <ul style="list-style-type: none"> <li>• Check if the foreign objects stuck in the fan.</li> <li>• Or contact SolaX for help.</li> </ul>
	BMS2_Fan	

## 11.4 Maintenance

Regular maintenance is required for the inverter. The table below lists the operational maintenance for expressing the optimum device performance. More frequent maintenance service is needed in the worse work environment. Please make records of the maintenance.



- Only qualified person can perform the maintenance for the inverter.
- Only use the spare parts and accessories approved by SolaX for maintenance.

### 11.4.1 Maintenance routines

Item	Check notes	Maintenance interval
Fans	<ul style="list-style-type: none"> <li>• Check if the cooling fans on the bottom of the inverter are covered by dirt or if there is abnormal sound.</li> <li>• Clean the cooling fans with a soft dry cloth or brush or replace it if necessary.</li> </ul>	Every 6-12 months
Electrical connection	<ul style="list-style-type: none"> <li>• Ensure that all cables are firmly connected.</li> <li>• Check the integrity of the cables, ensuring that there are no scratches on the parts touching the metallic surface.</li> <li>• Verify that the sealing caps on idle terminals terminals are and not falling off.</li> </ul>	Every 6-12 months
Grounding reliability	<ul style="list-style-type: none"> <li>• Check whether the ground terminal and ground cable are securely connected. Use Ground Resistance Tester to test the ground resistance from inverter enclosure to PE bar in the power distribution box.</li> </ul>	Every 6-12 months
Heat sink	<ul style="list-style-type: none"> <li>• Check whether the heat sink is covered with foreign objects.</li> </ul>	Every 6-12 months
General status of inverter	<ul style="list-style-type: none"> <li>• Check if there is any damage on the inverter.</li> <li>• Check if there is any abnormal sound when the inverter is running.</li> </ul>	Every 6 months

### 11.4.2 Replacement of Fans

When the fan is not rotating and the feedback speed of the fan is 0, the LCD screen will display FAN1FAULT / FAN2FAULT / FAN3FAULT / FAN4FAULT error. Refer to the following steps for replacement.

**Step 1:** Before the maintenance of fans, the AC connection must be disconnected, then

the DC switch 1 and DC switch 2 must be disconnected and wait 5 minutes till the inverter is completely OFF.

- Step 2:** Loosen the screws on the right side of the inverter with a cross screwdriver, and the nuts on the left side of the inverter.

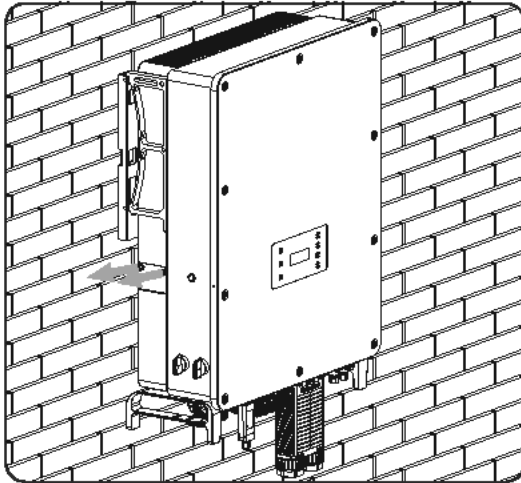

Figure 11-2 Dismantling screws

- Step 3:** Pull out the fan bracket, stop at the position about 150 mm, then press the protruding block with a screwdriver to release the fan waterproof connectors, then pull the fan bracket again to pull out the whole bracket.

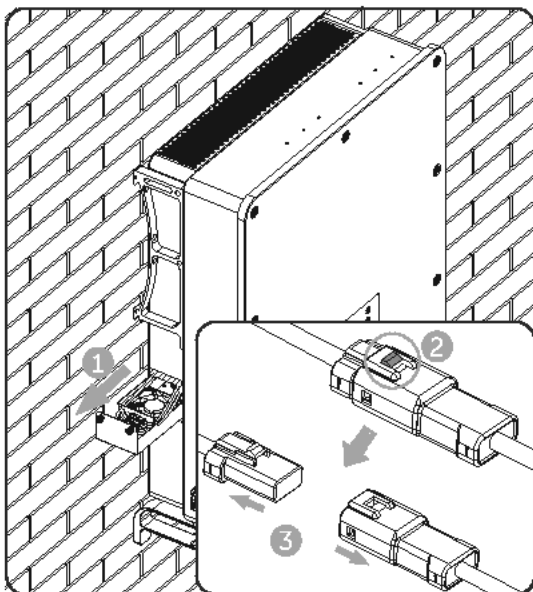

Figure 11-3 Releasing the fan waterproof connectors

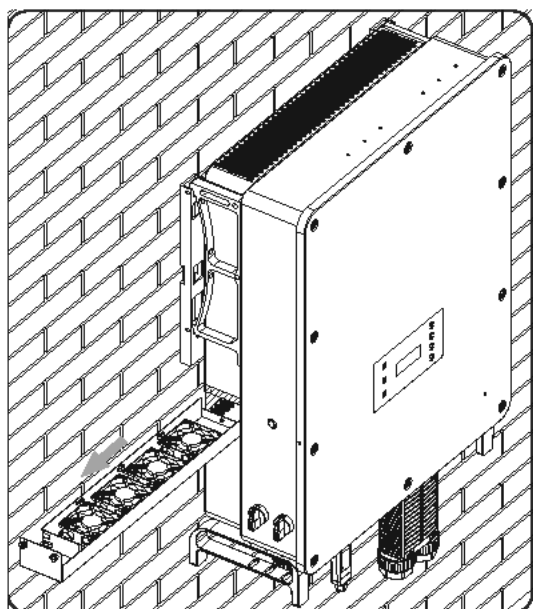

Figure 11-4 Pulling put the whole fan bracket

**Step 4:** Clean, repair, or replace the fan.

**Step 5:** Restore the installation of fan bracket and tighten the fixing screws.

### 11.4.3 Upgrading Firmware

#### Upgrade precautions

#### WARNING!

- Please make sure that the category format is correct. Do not modify the firmware file name. Otherwise, the inverter may not work!
- Do not modify the folder name and file path where the firmware files are located, as this may cause the upgrade to fail.

#### WARNING!

- Before proceeding with the upgrade process, ensure that the PV input voltage is above 180 V (preferably on sunny days), or that the battery (SOC) is above 20%, or the battery input voltage is above 180 V. Failure to meet these conditions may result in upgrade process failure.

#### Upgrade preparation

- Prepare a USB drive (USB 2.0/3.0, ≤32 GB, FAT 16/32).
- Check for the current firmware version of the inverter.
- Contact our service support for the update firmware file, and save it to the USB drive.
  - » For ARM file: XXX.XXXXX.XX\_AELIO\_3P\_ARM\_VXXX.XX\_XXXX.usb
  - » For DSP file: XXX.XXXXX.XX\_AELIO\_3P\_DSP\_VXXX.XX\_XXXX.usb
- Check the folder name and file path:

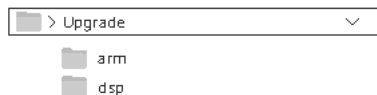
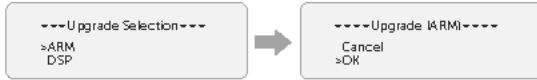

Figure 11-5 Folder name and path

#### Upgrade steps

- a. Press and hold the **Enter** key on the inverter LCD for 5 seconds to enter the **OFF** mode.

- b. Remove the dongle from the Dongle terminal of the inverter by hand, and then insert the USB drive. The inverter will automatically display the **Upgrade Selection** interface. (For the position of Dongle terminal, see "8.1 Terminals of Inverter".)
- c. On the **Upgrade Selection** interface, select **ARM** or **DSP** based on the file type, and then tap **OK**.



- d. Select and confirm the firmware version, and then tap the **Enter** key to start updating. ARM update takes about 20 seconds, and DSP update takes about 2 minutes.

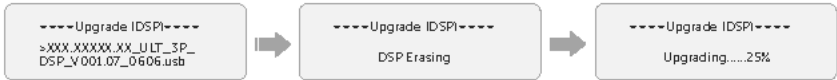
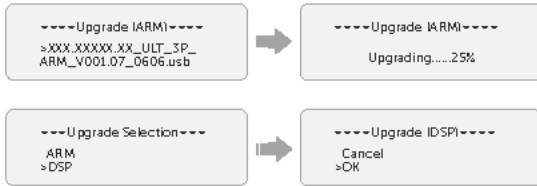

- e. After the upgrade is completed, the LCD screen displays **Upgrade Successful**. If the upgrades fail, the LCD screen displays **Upgrade failed**.

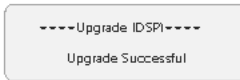

**CAUTION!**

- If the ARM firmware upgrade fails or stops, do not unplug the U disk. Please power off the inverter and restart it. Then repeat the upgrade steps.

**CAUTION!**

- If the DSP firmware upgrade fails or stops, please follow these steps:
- Check if the DC switch is turned off. If it is off, turn it on.
  - If the DC switch is already on, check if the battery and PV parameters in **Menu>System Status** meets the upgrade requirements (PV or battery input voltage is larger than 180V, or battery SOC is above 20%)
  - (Not recommended) Alternatively, you can try charging the battery by navigating to **Menu > Mode Select > Manual > Forced Charge**. This process can help wake up the battery for DSP upgrade.

NOTICE!

- If the display screen is stuck after the upgrade, please turn off the DC switch and restart, and the inverter will restart and return to normal. If not, please contact us for help.

# 12 Decommissioning

## 12.1 Disassembling the Inverter



- When disassembling the inverter, strictly follow the steps as below.
- Only use measuring devices with a DC input voltage range of 1000 V or higher.

**Step 1:** Disconnect the external AC breaker of the inverter.

**Step 2:** Turn the DC switch 1 and DC switch 2 to "OFF" position. Turn off the inverter system button.

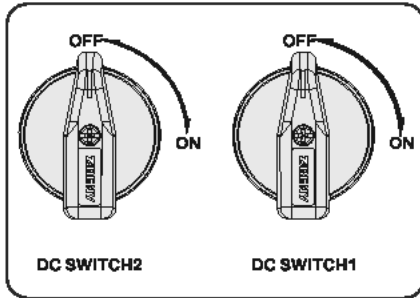

Figure 12-1 Turning off the DC switch

**Step 3:** Turn off the battery switch / button / breaker (if any). (See documents of battery)

**Step 4:** Wait until the LCD screen turns off.

**Step 5:** Disconnect the PV connectors: Insert the removal tool into the notch of PV connectors and slight pull out the connectors.

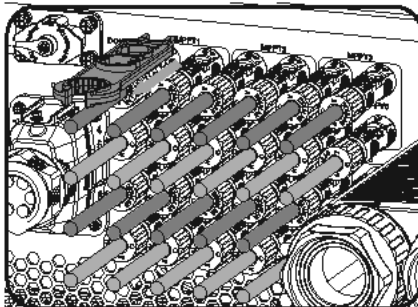

Figure 12-2 Releasing the PV connector

**Step 6:** Slight pull out the dongle module.

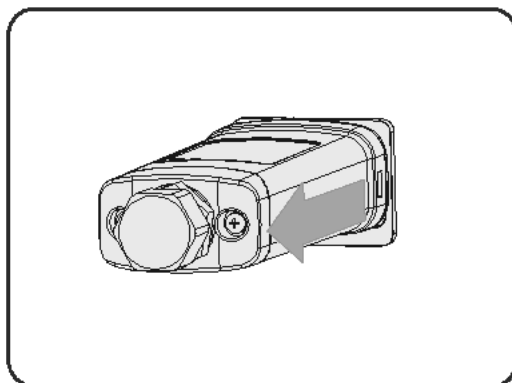

Figure 12-3 Removing the dongle

**Step 7:** Disconnect the battery connectors.

**Step 8:** Disconnect the AC connector: Loosen the M4 screws on the AC connector. Pull out the AC enclosure and release the screws securing the AC terminals.

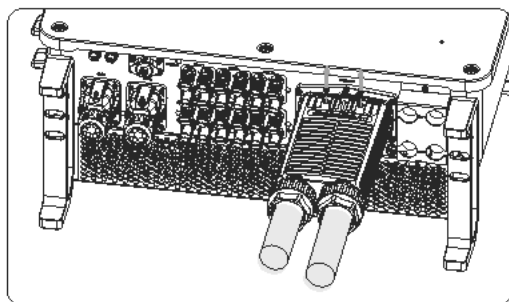

Figure 12-4 Removing AC connector

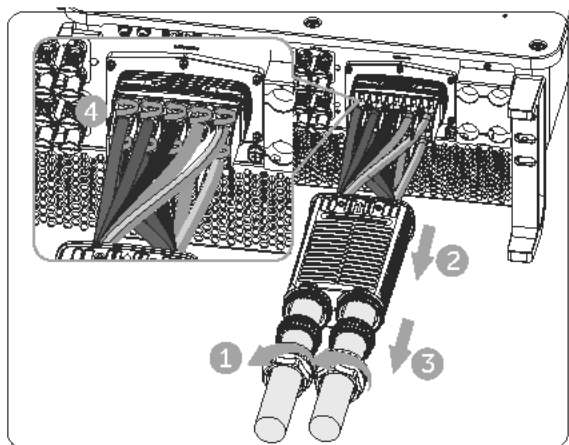

Figure 12-5 Removing AC terminals

- Step 9:** Disconnect the COM 1 connector and COM 2 connector: Please loosen the swivel nut of the COM connector and anti-clockwise loosen M3 screw of the communication connector by cross screwdriver. Pinch the tabs on the sides of the connector and pull the connector at the same time to remove it.
- Step 10:** Put the original terminal cap on the terminals.
- Step 11:** Unscrew the grounding screw by crosshead screw and remove the grounding cable.
- Step 12:** Unscrew the M5\*50 screws on the sides of inverter. (The inverter installed on the wall is taken for an example.)

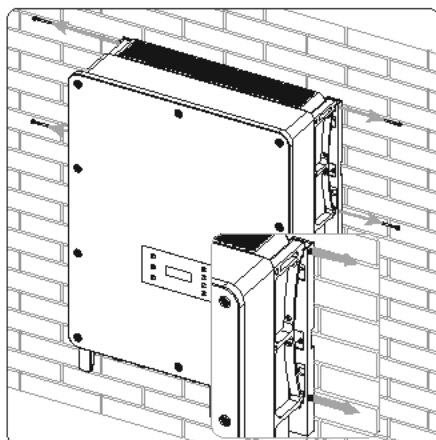

Figure 12-6 Unscrewing screws on the inverter

**Step 13:** Reinstall the eye bolts on the top of the inverter, use a crane to lift down the inverter. (The inverter installed on the wall is taken for an example.)

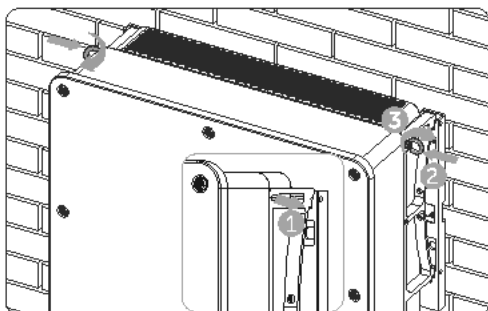

Figure 12-7 Reinstalling the eye bolts

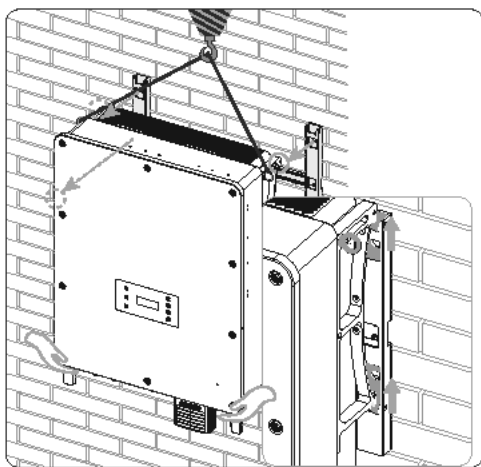

Figure 12-8 Lifting down the inverter

**NOTICE!**

- In case of personal injury or device damage, ladders will be helpful for installers to stand high and to adjust the inverter position when the inverter is lifted down from the wall mounting bracket.

**Step 14:** Unscrew the screws for fastening the wall mounting bracket and remove the wall mounting bracket.

## 12.2 Packing the Inverter

- Load the inverter into the original packing material if possible.

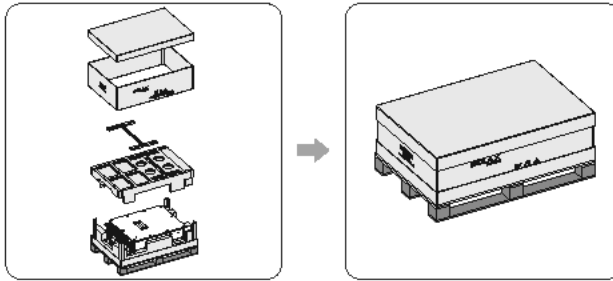

Figure 12-9 Packing the inverter

- If the original packing material is not available, use the packing material which meets the following requirements:
  - » Suitable for the weight of product
  - » Easy to carry
  - » Be capable of being closed completely

## 12.3 Disposing of the Inverter

Please dispose of the inverters or accessories in accordance with the electronic waste disposal regulations applicable at the installation site.

## 13 Technical Data

- DC input

Model	X3-AELIO-50K	X3-AELIO-60K	X3-AELIO-49.9K	X3-AELIO-61K	X3-AELIO-49.9K-P
Max. recommended PV array power [kWp]	100	120	100	122	100
Max. PV input power per MPPT [kW]			30		
Max. PV input voltage [V] <sup>①</sup>			1000		
Nominal PV input voltage [V]			650		
MPPT voltage range [V]			160-950		
Full load MPPT voltage range [V] <sup>②</sup>			320-800		
Start-up voltage [V]			200		
No. of MPP trackers	5	6	5	6	6
Strings per MPP tracker			2		
Max. PV current per MPPT [A] <sup>③</sup>			40		
Isc PV array short circuit current per MPPT [A] <sup>③</sup>			50		
Max. inverter backfeed current to the array [A]			0		
DC disconnection switch			Yes		

Note:

- ① The maximum input voltage represents the highest DC voltage threshold for the inverter, approaching which power derating occurs and any further increase might lead to potential damage to the inverter.
- ② PV voltage out of the full load MPPT range will trigger the inverter derating protection or possibly cause damage to the inverter if it exceeds the Max. input voltage.
- ③ Max. current for each PV input string is 35A

## Technical Data

### • AC output

Model	X3-AELIO-50K	X3-AELIO-60K	X3-AELIO-49.9K	X3-AELIO-61K	X3-AELIO-49.9K-P
Rated AC power [kW]	50	60	49.9	61	49.9
Max. AC output apparent power [kVA]	55	66	49.9	66	49.9
Nominal AC voltage [V]	3/N/PE, 400V/230V, 380V/220V				
Nominal AC frequency [Hz]	50/60, $\pm 5$ Hz				
Rated AC output current [A]	72.2	86.6	72.0	88.0	72.0
Max. AC output continuous current [A]	83.6	100.3	75.8	100.3	75.8
Current (inrush) (at 50 $\mu$ s) [A] (AC 280V, 90°)	104.0				
Adjustable power factor range	1 (-0.8-0.8)				
Total harmonic distortion (THDi, rated power)	<3%				
Maximum output fault current [A]	195	240	195	240	195
Maximum output overcurrent protection [A]	225	260	225	260	225
Feedin phases	3				

### • Battery

Model	X3-AELIO-50K	X3-AELIO-60K	X3-AELIO-49.9K	X3-AELIO-61K	X3-AELIO-49.9K-P
Battery voltage range [V]	180-820				
Recommended battery voltage [V]	650				
Max.charge / discharge power [kW]	50/50	60/60	49.9/49.9	61/61	49.9/49.9
Max.charge/discharge current [A]	160 (80*2)				
Battery connection	Yes				

- EPS output (with battery)

Model	X3-AELIO-50K	X3-AELIO-60K	X3-AELIO-49.9K	X3-AELIO-61K	X3-AELIO-49.9K-P
Rated EPS voltage [V] Frequency [Hz]	400/230V, 50/60Hz				
Rated EPS output power [kW]	50	60	49.9	61	49.9
Peak EPS output power [kW]	*55/ 75kVA for 10s*	*66/ 90kVA for 10s*	*55/ 75kVA for 10s*	*66/ 90kVA for 10s*	*55/ 75kVA for 10s*
Switch time [s]	<10ms				
Total harmonic distortion (THDi)	<3%				

- Efficiency

Model	X3-AELIO-50K	X3-AELIO-60K	X3-AELIO-49.9K	X3-AELIO-61K	X3-AELIO-49.9K-P
European efficiency	97.20%				
Max. efficiency	98.00%				

- Environment limit

Model	X3-AELIO-50K	X3-AELIO-60K	X3-AELIO-49.9K	X3-AELIO-61K	X3-AELIO-49.9K-P
Ingress protection	IP66				
Operating ambient temperature range [°C]	-35~60				
Relative Humidity (condensing) [%]	0~100				
Altitude [m]	<3000				
Storage temperature [°C]	-40~+70				
Over voltage category	PV: II + Main: III				

## Technical Data

- General

Model	X3-AELIO-50K	X3-AELIO-60K	X3-AELIO-49.9K	X3-AELIO-61K	X3-AELIO-49.9K-P
Dimensions (WxHxD) [mm]	820x670x257				
Weight [kg]	<100	<105	<100	<105	<105
Cooling concept	Smart air cooling				
Topology	Non-isolated				
Communication	RS485, CAN-BMS, CAN-Parallel, USB, DI, DO, DRM				
LCD display	Optional				
SPD	PV Type II+AC Type II				
AFCI	Optional				

Note:

\* The specific gross weight is subject to the actual situation of the whole machine.

- Standard

Model	X3-AELIO-50K	X3-AELIO-60K	X3-AELIO-49.9K	X3-AELIO-61K	X3-AELIO-49.9K-P
Safety	EN/IEC 62109-1/-2				
EMC	EN/IEC 61000-6-1/-2/-3/-4; EN/IEC 61000-3-2/-3/-11/-12; EN 55011; IEC 62920;				
Certification	VDE4105, G99, AS4777, EN50549, CEI 0-21, IEC 61727, PEA/MEA, NRS-097-2-1, RD1699, TOR				

# 14 Appendix

---

## 14.1 Generator Application

### 14.1.1 Introduction of generator application

In certain regions where utility power is unstable, the use of generators becomes necessary to ensure uninterrupted operation of loads. The characteristic of this system is its ability to seamlessly switch to generators combined with an energy storage system, forming a new power supply configuration in the absence of utility power.

A diesel generator is employed to replicate grid-like functionality, while a hybrid inverter converts solar energy into usable electric energy.

### 14.1.2 Notice for generator application

- Note 1: The generator should be equipped with an ATS, enabling it to start automatically in the event of a power outage.
- Note 2: The rated output power of the generator should be greater than the sum of the load power and the battery charging power. If there are two inverters in parallel, the rated output power of the generator should be greater than the sum of the load power and the battery charging power of the two inverters.
- Note 3: If the rated output power of the generator is small and cannot meet the requirements of Note 2, the setting value of **MaxChargePower** can be changed in the **Menu>Setting>Advance Setting>ExternalGen** to ensure that the generator power can meet the load and battery charging use at the same time.
- Note 4: The EPS load power cannot be greater than the battery discharge power to prevent the battery power from being unable to meet the EPS load after the generator shuts down and the inverter will report **Overload fault**. If two inverters are paralleled, the EPS load power shall be doubled.

### 14.1.3 ATS control mode

In this operating mode, the generator functions as a substitute for the grid. There is no communication between the generator and the inverter, which means no wiring modifications are required (however, the inverter is also unable to control the generator). The ATS that accompanies the generator will determine whether the generator should be turned on or off based on the status of the grid.

Wiring connection diagram

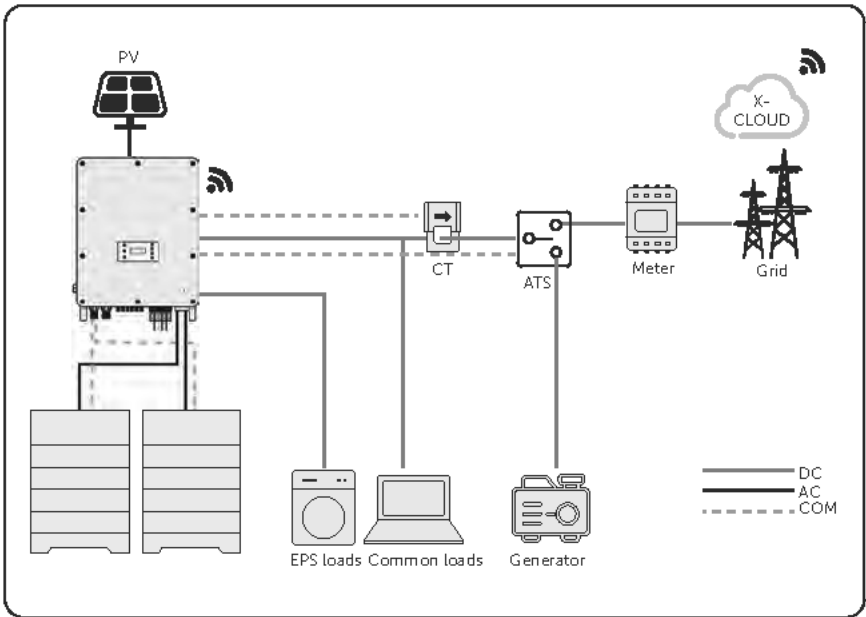
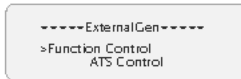

Figure 14-1 ATS control wiring diagram

Inverter settings for ATS control mode

Setting path: **Menu>Setting>Advance Setting>ExternalGen**

- a. Select and enter **ExternalGen** interface and select **ATS Control**.



- b. Set the relative parameters as below in accordance with actual needs.

- » **MaxChargePower**: Maximum battery charging power from generator. (0-30000 W, 5000W by default)

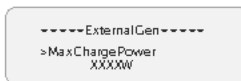

- » **Char&Disc Period**: Including **Forced Charge Period** and **Allowed Disc Period**. Two periods can be set. These period settings are associated with the same settings under **Work Mode** for no need to jump to work mode page to set

the working period when using generator mode.

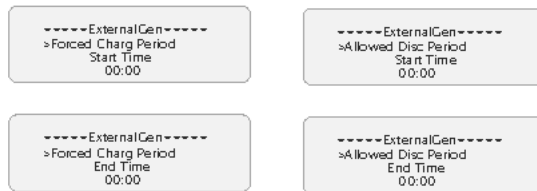

- » **Charge from Gen and Charge battery to:** The SOC which allows the system charging from generator. (10-100%, 10% by default)

#### 14.1.4 Dry contact mode

In this operating mode, users can intelligently control the system by establishing a dry contact connection between the inverter and the generator. It allows for a variety of settings to be adjusted, enabling the system to adapt to different scenarios and meet specific requirements.

#### Wiring connection diagram

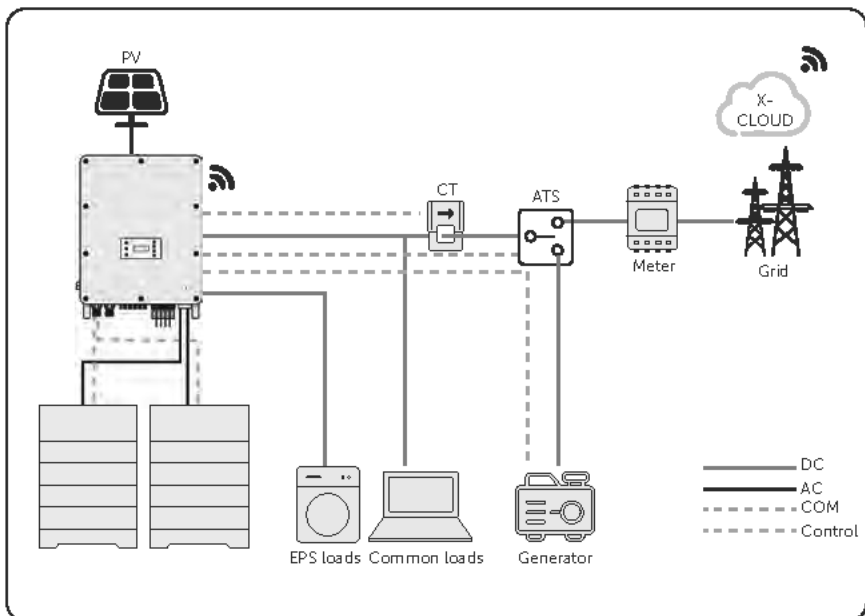

Figure 14-2 Dry contact wiring diagram

Inverter connection for dry contact mode

- Connection terminal-DIO terminal

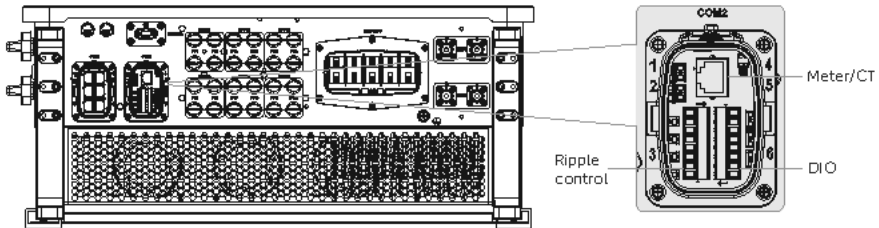

Figure 14-3 Connection terminal for generator

- Connection pins-Pin 1 and Pin 2

Table 14-1 Connection pins for generator

Application	Generator dry contact output		System switch dry contact input		Reserved		Power supply	
Pin	1	2	3	4	5	6	7	8
Assignment	DO_1	DO_2	DI_1+	DI_1-	DI_2+	DI_2-	GND_COM	EPSBOX_RELAY_VCC

- Connection steps

Please refer to “8.7.4 DIO Communication Connection” for specific wire making and connection.

③ Inverter settings for dry contact mode

Setting path: **Menu>Setting>Advance Setting>ExternalGen**

- a. Select and enter **ExternalGen** interface and select **Dry Contact**.



- b. Set the relative parameters in accordance with actual needs.

- » **MaxChargePower**: Maximum battery charging power from generator. (0-30000 W, 5000W by default).

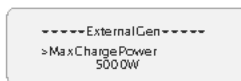

- » **Start Gen Method**: **Reference SOC** and **Immediately** can be selected.
  - Reference SOC**: Turn on/off generator according to the set **Switch on/off SOC**.
  - Immediately**: Turn on /off the generator when grid status changed.

-----ExternalGen-----

>Start Gen Method  
Reference soc

-----ExternalGen-----

>Start Gen Method  
Immediately

- » **Switch on/off SOC:** the option is activated when you select **Reference SOC** for **Start Gen Method**. Inverter will turn on the generator when the battery reaches the set **Switch on SOC** and turn it off when the battery reaches the set **Switch off SOC**.

-----ExternalGen-----

>Switch on SoC  
0%

-----ExternalGen-----

>Switch off SoC  
0%

- » **MaxRunTime:** Maximum operating time of generator. (30 Min by default)

-----ExternalGen-----

>MaxRunTime  
30Min

- » **MinRestTime:** Minimum time interval for two consecutive starts to avoid frequent generator on and off.

-----ExternalGen-----

>MaxRestTime  
0Min

- » **Charge & Disc Period:** Including **Forced Charge Period** and **Allowed Disc Period**. Two periods can be set. These period settings are associated with the same settings under **Work Mode** for no need to jump to work mode page to set the working period when using generator mode.

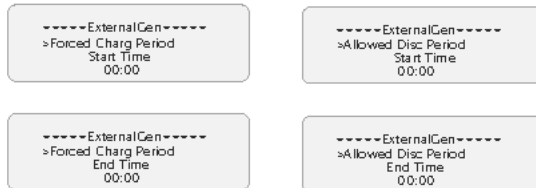

- » **Allow Work:** Allowed time period for generator operating. You can set the start time and end time.



- » **Charge from Gen and Charge battery to:** The SOC which allows the system charging from generator. (10-100 W from generator, 10% by default)



## 14.2 Adapter Box Application

### 14.2.1 Introduction of Adapter Box application

SolaX offers a comprehensive solar home energy management solution by integrating a heating solution into its existing system. With the SolaX Adapter Box G2, users can effectively utilize solar energy by commanding it to power their heat pump using settings available on the SolaX inverter and SolaXCloud. This intelligent integration allows for optimized solar self-consumption and ultimately helps in reducing electricity bills.

### 14.2.2 Wiring connection diagram

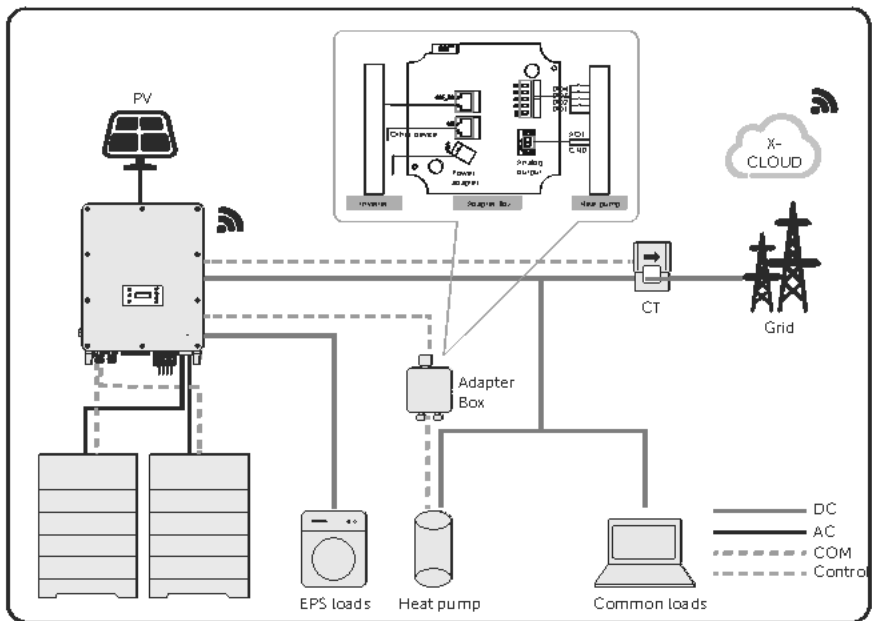

Figure 14-4 Adapter Box wiring diagram

The inverter communicates with Adapter Box via RS485. In case of excess power, the Adapter Box can utilize it to heat the pump through the connection of dry contacts, SG Ready, or Analog output between the Adapter Box and the heat pump. To power the Adapter Box, an external power adapter is required as the inverter itself cannot supply power to the Adapter Box.

### 14.2.3 Communication connection with inverter

- Connection terminal-RS485 terminal

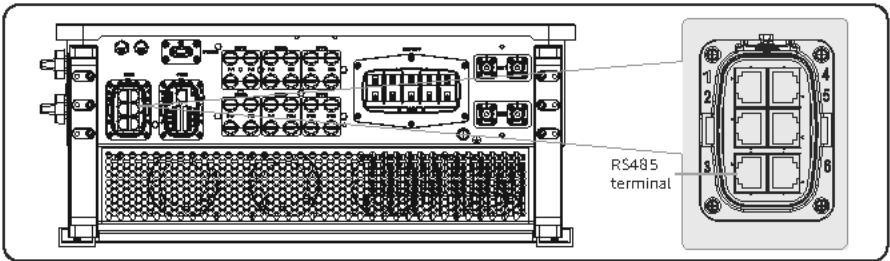

Figure 14-5 Connection terminal for Adapter Box

- Connection pins

Table 14-2 Pin-to-pin connection for inverter and Adapter Box

RS485 terminal of inverter		RS485_INV terminal of Adapter Box	
Pin	Pin definition	Pin	Pin definition
4	PARALLEL_485AA	4	RS485-A
5	PARALLEL_485BB	5	RS485-B

- Connection steps

Please refer to "8.6.4 RS485 Communication Connection" for specific wire making and connection.

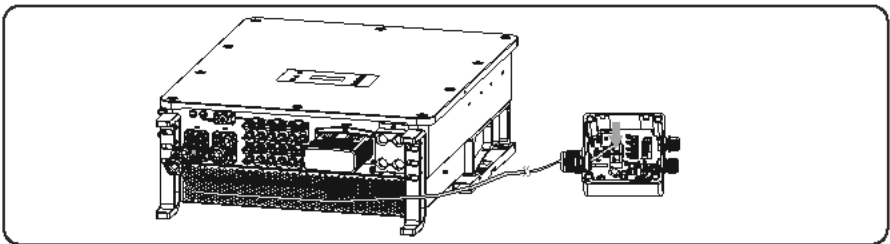

Figure 14-6 Connecting to Adapter Box

**NOTICE!**

- Please refer to *Adapter Box G2 User Manual* for specific connection between power adapter and Adapter Box G2 and between heat pump and Adapter Box G2.

## 14.2.4 Settings for Adapter Box

Setting path: **Menu>Setting>Advance Setting>Internal485**

- Select and enter **Internal485** interface;
- Select the **AdapBox G2** and set the **Baud Rate** and corresponding Address.

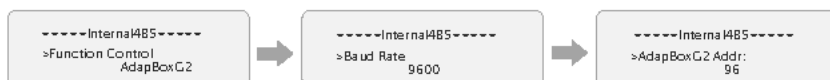

### NOTICE!

- When two equipments need to be connected at the same time, the baud rate and address of the two equipments shall be set to the same.

- Check the connecting status.



### NOTICE!

- Please refer to the *Adapter Box G2 User Manual* for specific parameter setting and wiring.

## 14.3 EV-Charger Application

### 14.3.1 Introduction of EV-Charger application

The X3-EVC series are AC EV charger and intended for charging electric vehicles. It should be installed in a fixed location and connected to the AC supply. The EV-Charger can communicate with other devices or systems (inverter, meter, CT, third-party charger management platform, etc.) to realize intelligent control of charging process.

### 14.3.2 Wiring connection diagram

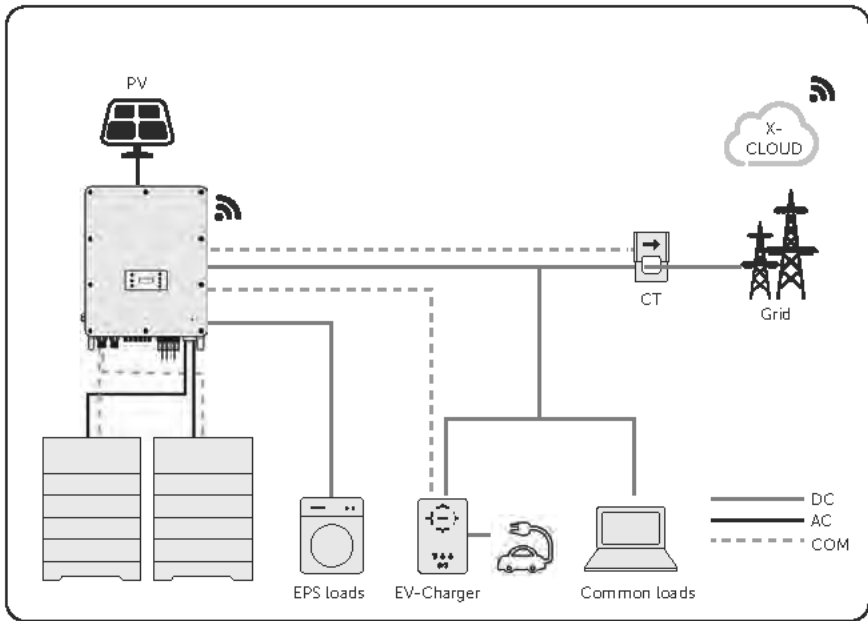

Figure 14-7 EV-Charger wiring diagram

### 14.3.3 Charging modes

The EV-Charger can work with the inverter system which supports communication with it to form an intelligent photovoltaic, storage and EV charging energy system. Through communicating with the inverter, the EV-Charger can obtain the current information of the grid and PV and realize the smart control of different charging modes.

- Green mode: In Green mode, the EV-Charger will maximize the use of surplus power generated from the inverter. According to the minimum start-up charging power, the charging current can be divided into two levels as 3 A and 6 A. The

default level is 3 A.

- Eco mode: In Eco mode, the charging power is continuously adjusted according to changes in generation or power consumption elsewhere in the house, thereby minimizing the use of the grid power. In this mode, users can set charging current at five different levels, i.e. 6 A, 10 A, 16 A, 20 A and 25 A (Only 6 A & 10 A for 11 kW models). If at any time, the available surplus power falls below the minimum start-up charging power, such as 4.2 kW for three-phase, the shortfall will be drawn from the grid.
- Fast mode (Default mode): In Fast mode, the EV-Charger will charge the EV at the fastest rate regardless of whether the power generated by PV is sufficient and import grid electricity if the power generated by PV is insufficient.

### 14.3.4 Communication connection with inverter

- Connection terminal-RS485 terminal

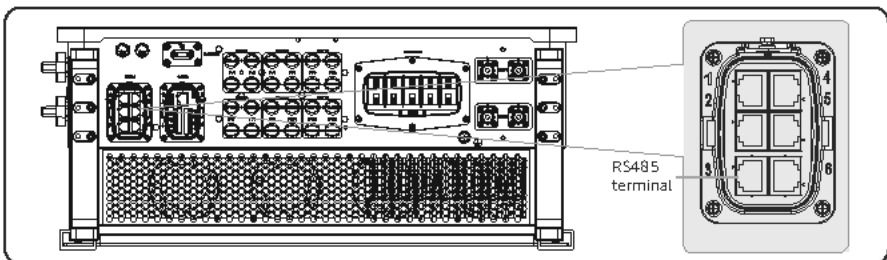

Figure 14-8 Connection terminal for EV-Charger

- Connection pins

Table 14-3 Pin-to-pin connection for inverter and EV-Charger

RS485 terminal of inverter		COM terminal of EV-Charger	
Pin	Pin definition	Pin	Pin definition
4	PARALLEL_485AA	5	B1
5	PARALLEL_485BB	4	A1

- Connection steps

Please refer to "8.6.4 RS485 Communication Connection" for specific wire making and connection.

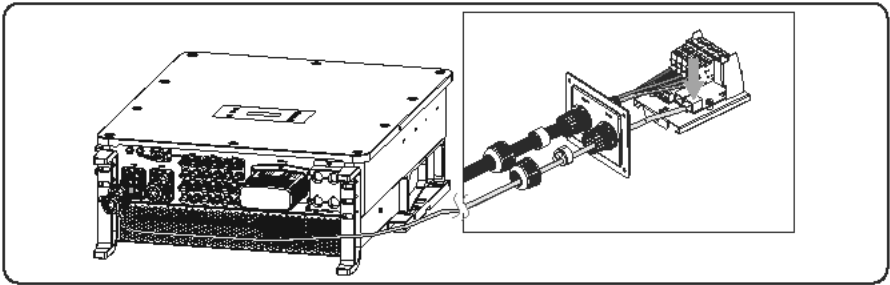

Figure 14-9 Connecting to EV-Charger

### 14.3.5 Setting for EV-Charger

Setting path: **Menu>Setting>Advance Setting>Internal485**

- a. Select and enter **Internal485** interface;
- b. Select the **EV Charger** and set the **Baud Rate** and corresponding Address.



#### NOTICE!

- When two equipments need to be connected at the same time, the baud rate and address of the two equipments shall be set to the same.

- c. Check the connecting status.



- d. You can enable **Battery Charge EVC** to allow the battery to discharge energy to EV-Charger through setting path: **Menu>Setting>Advance Setting>Battery Charge EVC**.

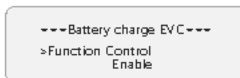

#### NOTICE!

- Please refer to *X1/X3-EVC Series User Manual* for specific setting and wiring connection on the EV-Charger.

## 14.4 Micro-grid Application

### 14.4.1 Introduction of Micro-grid application

Due to Islanding Effect, on-grid inverter is unable to work during off-grid. This characteristic makes user losing the on-grid inverter PV energy when off-grid. Micro-grid is the function that making hybrid inverter simulate the grid to active on-grid inverter during off-grid by connecting on-grid inverter to hybrid inverter's EPS terminal.

### 14.4.2 Wiring conenction diagram

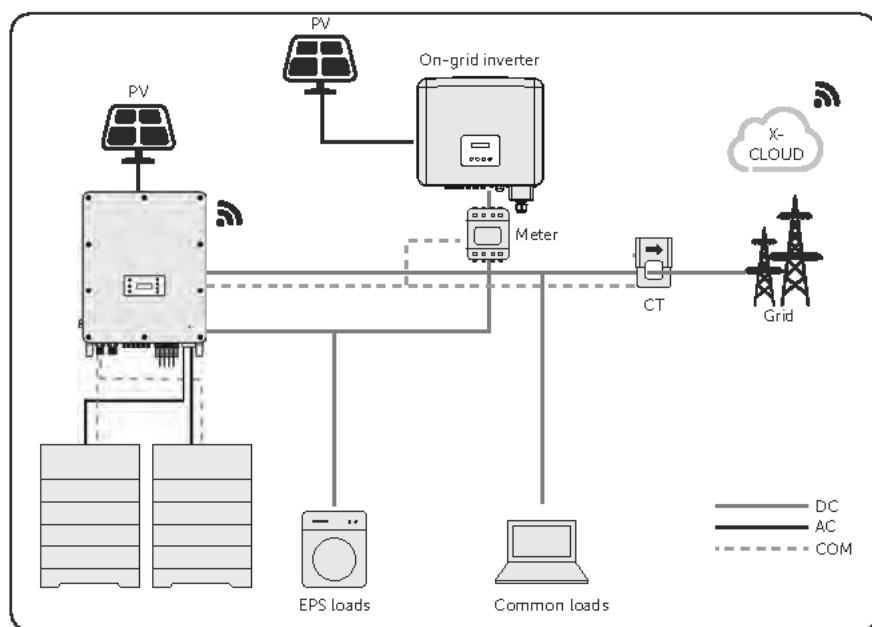

Figure 14-10 Micro-grid wiring connection

### 14.4.3 Working modes

#### Grid on

- When PV is sufficient, the hybrid and on-grid inverters power the general and critical loads together. When there is surplus energy on the on-grid inverter, it will also charge the battery connected to the hybrid inverter.
- When PV is insufficient, the hybrid, on-grid inverter and grid power all the loads.

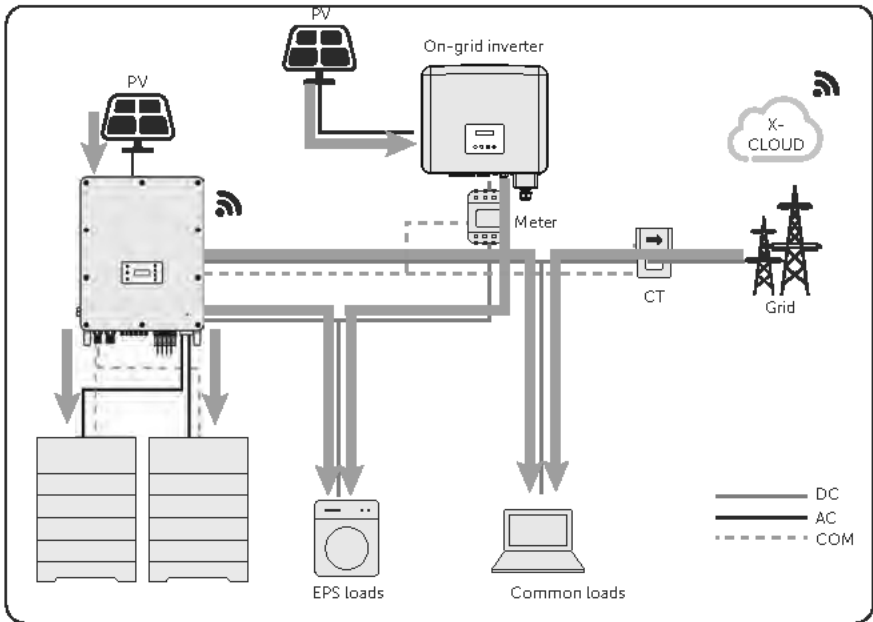

Figure 14-11 Power flowing when grid on and PV sufficient

## Grid off

In this case, the hybrid inverter will simulate the grid so as to make the on-grid inverter can still work. Hybrid and on-grid inverter will power the EPS loads together. If there is surplus energy, it will charge the battery.

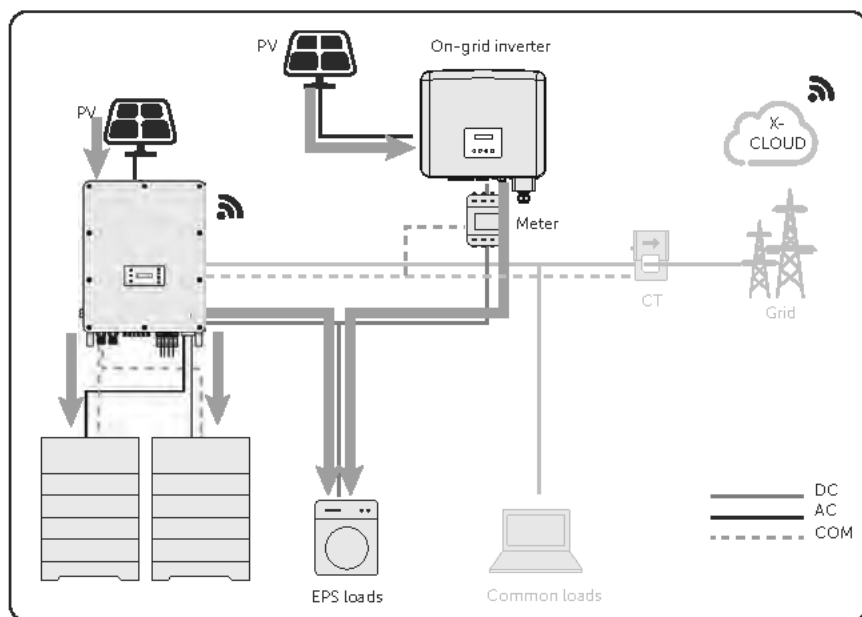

Figure 14-12 Power flowing when grid off

## Notice for micro-grid application

- Any brand of on-grid inverter that supports "frequency adaptation"
- On-grid inverter output power  $\leq$  Max hybrid inverter EPS output power
- On-grid inverter output power  $\leq$  Max battery charging power, refer to the table below:

### NOTICE!

- Since X3-AELIO series inverter is unable to control the output power of on-grid inverter in grid connection mode, therefore X3-AELIO series inverter can not achieve zero export when loads power + battery charging power  $<$  on-grid inverter output power.

### 14.4.4 Cable connection (Hybrid inverter)

Please refer to "8.3 AC Connection" for Grid and EPS connection on X3-AELIO series inverter.

### 14.4.5 Cable connection (On-grid inverter)

Please connect the AC cable of on-grid inverter to the EPS terminal of X3-AELIO series inverter through a circuit breaker. Please refer to the user manual of specific on-grid inverter.

### 14.4.6 Cable connection (Meter)

To detect and monitor the power data generated from the on-grid inverter, you can install a meter on the on-grid inverter side. Otherwise, the relevant power data of on-grid inverter can not be monitored.

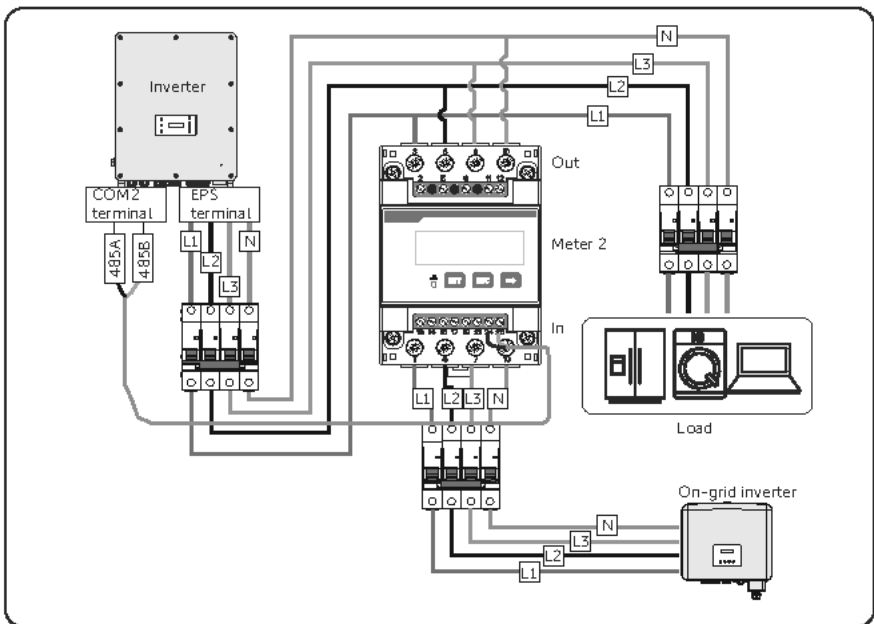

Figure 14-13 Connection diagram of Meter on EPS terminal

## NOTICE!

- If one-to-two adapter for RJ45 terminal is used, it should be placed in a waterproof enclosure.

- Pin definition

Table 14-4 Pin definition for meter and CT

Application	For CT1			For meter		For CT2		
Pin	1	2	3	4	5	6	7	8
Assignment	CT_ R1_ CON	CT_ S1_ CON	CT_ T1_ CON	METER _485A	METER _485B	CT_ T2_ CON	CT_ S2_ CON	CT_ R2_ CON

- Meter/CT connection steps

Please refer to “8.7.2 Meter/CT Connection” and meter/CT user manual for specific connection steps.

- Setting on the LCD

Setting path: **Menu>Setting>Advance Setting>Meter/CT Setting**

① For meter 1 and meter 2 solution (Meter 1 for girdi connection, Meter 2 for EPS connection)

- Select and enter the **Meter/CT Setting** according the setting path.
- Set the the address and direction of Meter 1: You can check the connection status in **Meter/CT Check**.

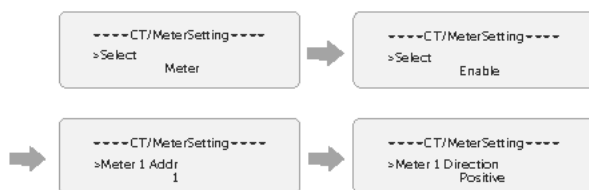

- Set the the address and direction of Meter 2: You can check the connection status in **Meter/CT Check**.



- After connection succeeded, check the feed-in power of Meter 1 in the path of **Menu>System Status>Meter/CT** and check the output power (**Output Today** and **Output Total**) of Meter 2 in the path of **Menu>History Data>E\_USERDEF**.

② For CT and meter 2 solution (CT for grid connection, Meter 2 for EPS connection)

- a. Select and enter the **Meter/CT Setting** according the setting path.
- b. Select and enable the CT function, select the CT. You can check the connection status in **Meter/CT Check**.

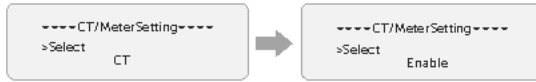

- c. Set the the address and direction of Meter 2: You can check the connection status in **Meter/CT Check**.



- d. After connection succeeded, check the feed-in power of Meter 1 in the path of **Menu>System Status>Meter/CT** and check the output power (**Output Today** and **Output Total**) of Meter 2 in the path of **Menu>History Data>E\_USERDEF**.

## 14.5 Application of Parallel Function

### 14.5.1 Introduction of parallel application

The series inverters supports parallel operation in both Grid and EPS modes. It supports up to 3 units in the parallel system when not equipped with a parallel cabinet, and supports up to 5 units in the parallel system when equipped with a 300kW parallel cabinet. Details as follows:

Table 14-5 Maximum inverter number in parallel system

Model	X3-AELIO-50K	X3-AELIO-60K	X3-AELIO-49.9K	X3-AELIO-61K	X3-AELIO-49.9K-P
Without X3-PBOX-300kW			3		
With X3-PBOX-300kW	6	5	6	5	6

### 14.5.2 Notice for parallel application

- All inverters should be of the same software version.
- For optimal efficiency, it is recommended that all inverters have the same model, and are connected to batteries of the same model and quantity.
- In parallel system, there are three status: **Free**, **Slave** and **Master**.

Table 14-6 Three status

Free	Only if no one inverter is set as a <b>Master</b> , all inverters are in <b>Free</b> mode in the system.
Slave	Once one inverter is set as a <b>Master</b> , all other inverters will enter <b>Slave</b> mode automatically. <b>Slave</b> mode can not be changed from other modes by LCD setting.
Master	When one inverter is set as a <b>Master</b> , this inverter enters <b>Master</b> mode. <b>Master</b> mode can be changed to <b>Free</b> mode.

- Master inverter has an absolute lead in the parallel system to control all slave inverter's energy management and dispatch control. Once master inverter has some error and stop working, all slave inverters will be stop simultaneously. But master inverter is independent of all slave inverters to work and will not be affected by slave inverter's fault.
- Overall system will be running according to master inverter's setting parameters, and most setting parameters of slave inverter will be kept but not be cancelled.
- Once slave inverter exits from the system and be running as an independent unit (the network cable is disconnected simultaneously), its all setting will be re-activated.

- The parallel system is extremely complex and requires a large number of cables to be connected. Therefore, the cables must be connected in the correct wire sequence. Otherwise, any small mistake can lead to system failure.
- The communication cable length should not exceed 40 m.

### 14.5.3 System wiring diagram

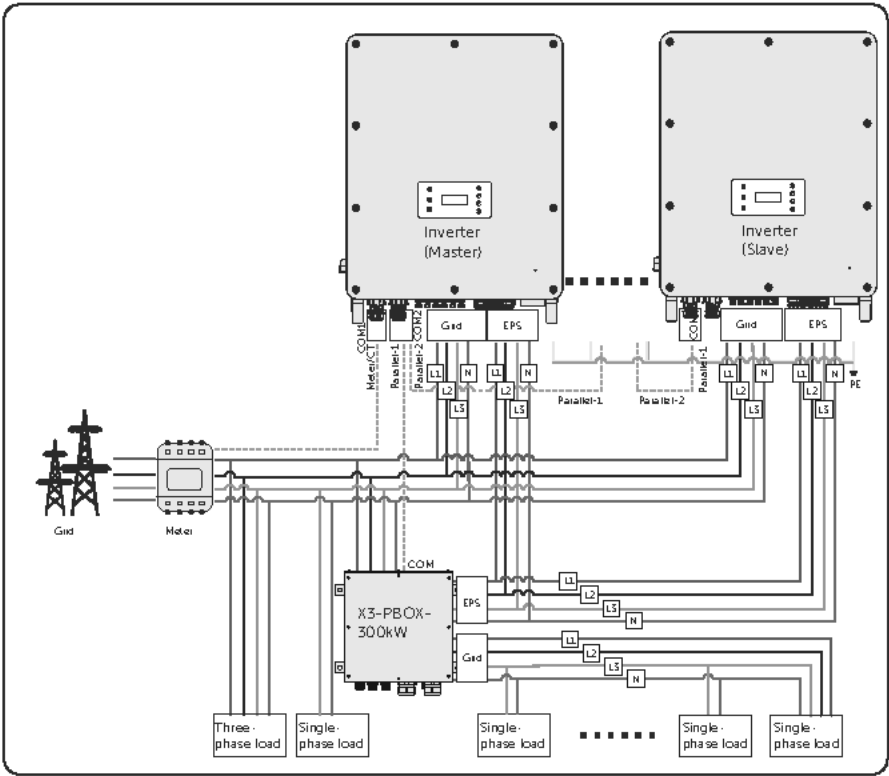

Figure 14-14 With X3-PBOX-300kW system wiring diagram

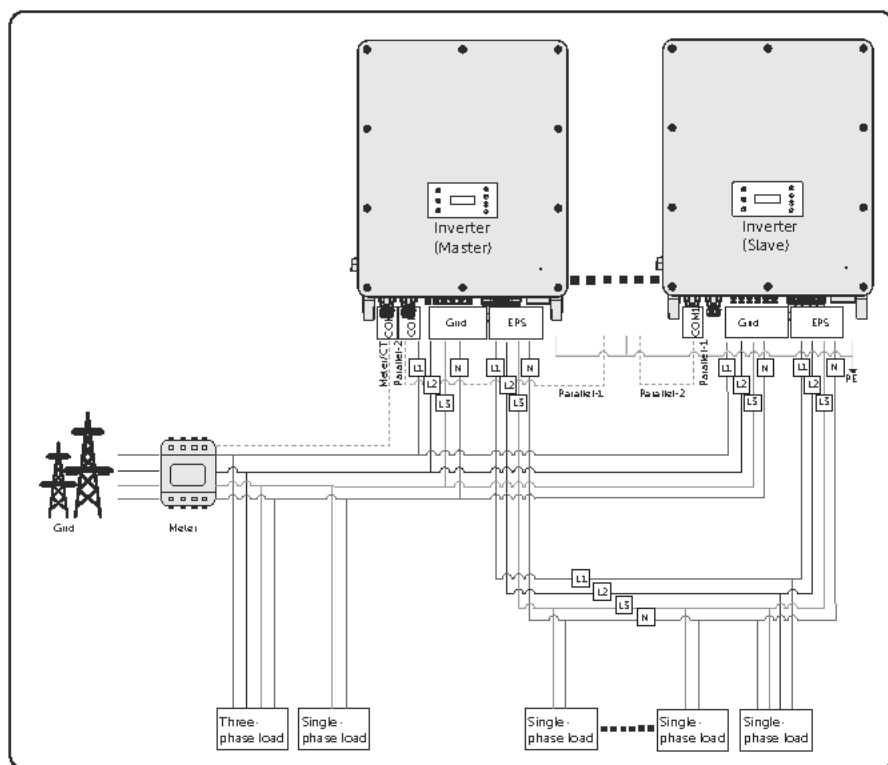

Figure 14-15 Without X3-PBOX-300kW system wiring diagram

### 14.5.4 System wiring procedure

#### Power cable wiring-Grid and EPS terminal

- With X3-PBOX-300kW:
  - a. User five-core copper cable to connect Master-Slave inverter and Master-X3-PBOX-300kW.
  - b. Grid terminal of Master, Slave inverter and X3-PBOX-300kW: L1 connects to L1, L2 connects to L2, L3 connects to L3 and N connects to N,
  - c. EPS terminal of Master, Slave inverter and X3-PBOX-300kW: L1 connects to L1, L2 connects to L2, L3 connects to L3 and N connects to N,
  - d. All PE cable connects to the same E-BAR nearby.

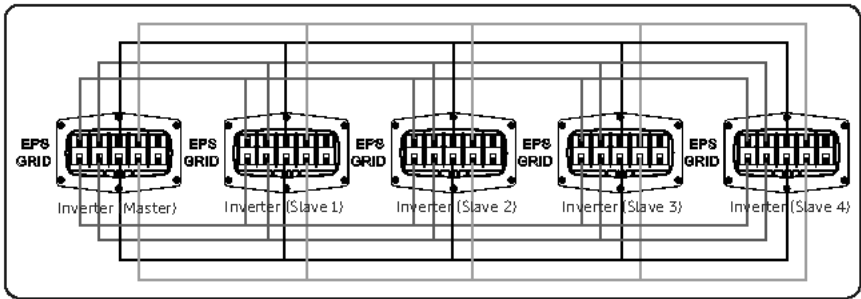

Figure 14-16 Power cable wiring with X3-PBOX-300kW

- Without X3-PBOX-300kW:
  - a. User five-core copper cable to connect Master-Slave inverter.
  - b. Grid terminal of Master and Slave inverter: L1 connects to L1, L2 connects to L2, L3 connects to L3 and N connects to N,
  - c. EPS terminal of Master and Slave inverter: L1 connects to L1, L2 connects to L2, L3 connects to L3 and N connects to N,
  - d. All PE cable connects to the same E-BAR nearby.

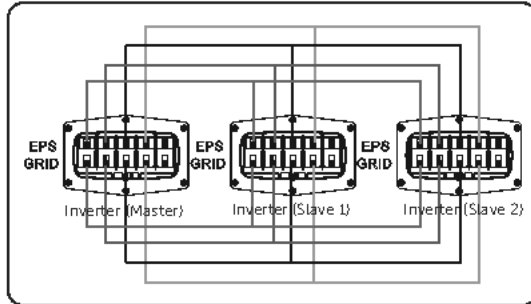

Figure 14-17 Power cable wiring without X3-PBOX-300kW

### Communication cable wiring-COM1 terminal and COM2 terminal

- With X3-PBOX-300kW:
  - a. Use standard network cables for Master-Slave inverter connection.
  - b. Master inverter Parallel-1 connects to the COM terminal of X3-PBOX-300kW.
  - c. Master inverter Parallel-2 connects to Slave 1 inverter Parallel-1;
  - d. Slave 1 Parallel-2 connects to Slave 2 Parallel-1; other inverters are connected in such way.
  - e. Meter connects to Meter/CT terminal of the Master inverter. Please refer to "8.7.2 Meter/CT Connection".

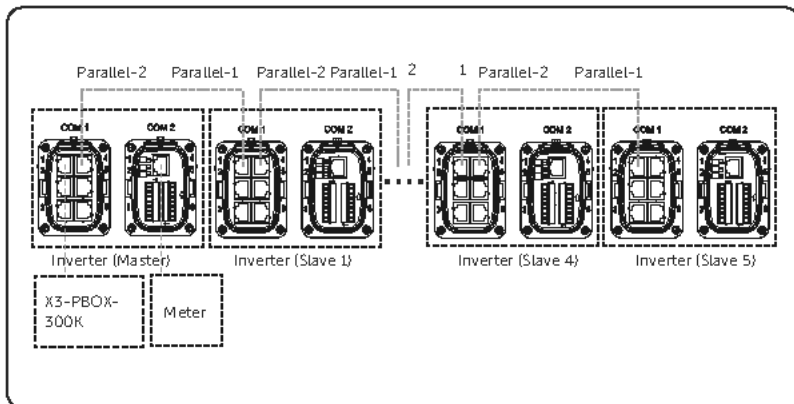

Figure 14-18 Communication wiring with X3-PBOX-300kW

- Parallel connection without X3-PBOX-300kW:
  - a. Use standard network cables for Master-Slave inverter connection.

- b. Master inverter Parallel-2 connects to Slave 1 inverter Parallel-1.
- c. Slave 1 inverter Parallel-2 connects to Slave 2 inverter Parallel-1.
- d. Meter connects to Meter/CT terminal of the Master inverter. Please refer to "8.7.2 Meter/CT Connection".

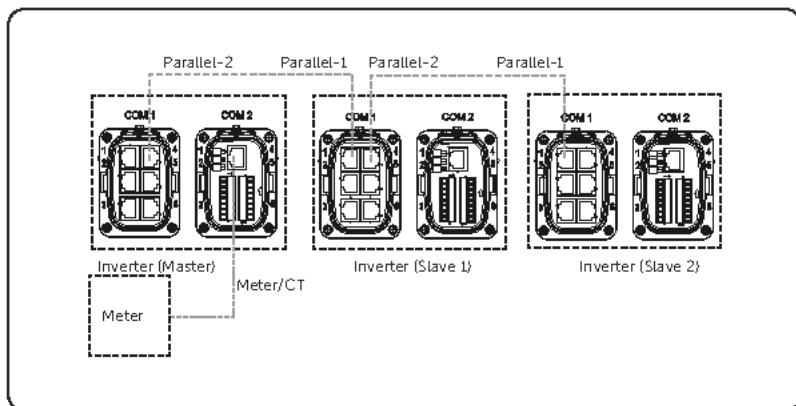

Figure 14-19 Communication wiring without X3-PBOX-300kW

**NOTICE!**

- For details on the parallel connection of X3-PBOX-300kW, see *X3-PBOX-300kW Installation Guide*.
- For details on the specific wiring of the inverter, see "8.3 AC Connection" and "8.6.2 Parallel Connection".

## 14.5.5 Settings for parallel connection

### Meter/CT setting

Setting path: **Menu>Setting>Advance Setting>Meter/CT Setting**. For details, see "Meter/CT Setting".

### Parallel setting

Setting path: **Menu>Setting>Advance Setting>Parallel Setting**.

#### How to build the parallel connection

- Turn on the power of the entire system, find the inverter which needs to be set as Master and connect the meter to Master inverter, enter the setting page of the Master inverter LCD screen, select the **Parallel Setting**, and select **Master**; then enter the **Resistance Switch** and set it to **ON**;



- Find the last slave in the parallel system and enter the setting page of the inverter LCD screen and set the **Resistance Switch** to **ON**.

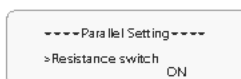

#### How to remove the parallel connection

- Find the inverter which needs to be set as Free. Select the **Parallel Settings** and select **Free** for the inverter.



- Disconnect all the network cables on the Parallel-1 and Parallel-2 port.

#### NOTICE!

- If a slave inverter is set to **Free** mode but not disconnect the network cable, this inverter will return to **Slave** mode automatically.
- If a slave inverter is disconnected with master inverter but not be set to **Free** mode, this slave inverter will stop working and prompt **ParallelFault**.

### External ATS setting

Setting path: **Menu>Setting>Advance Setting>External ATS**.

When the X3-PBOX-300K is connected in the parallel system, enable the function.

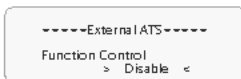

## Parallel display

Displaying path: **Menu>Parallel Status**

NOTICE!

- Once inverter enters parallel system, the **Today** yield will be replaced by **Parallel**.

In **Parallel Status** interface, the whole system power and individual slave inverter power can be obtained in **Parallel Status** interface of master inverter. The number displayed in the **Parallel Status** interface refers to the total number of online inverters, for example two inverters in parallel in the below figure.

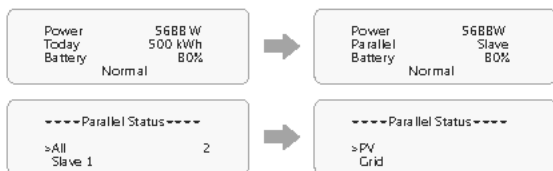

# Contact Information



## UNITED KINGDOM

---

 Unit C-D Riversdale House, Riversdale  
Road, Atherstone, CV9 1FA  
 +44 (0) 2476 586 998  
 [service.uk@solaxpower.com](mailto:service.uk@solaxpower.com)

## TURKEY

---

 Fevzi Cakmak mah. aslim cd. no 88 A  
Karatay / Konya / Turkiye  
 [service.tr@solaxpower.com](mailto:service.tr@solaxpower.com)



## USA

---

 3780 Kilroy Airport Way, Suite 200, Long  
Beach, CA, US 90806  
 +1 (408) 690 9464  
 [info@solaxpower.com](mailto:info@solaxpower.com)



## POLAND

---

 WARSAW AL. JANA P. II 27. POST  
 +48 662 430 292  
 [service.pl@solaxpower.com](mailto:service.pl@solaxpower.com)

## ITALY

---

 +39 011 19800998  
 [support@solaxpower.it](mailto:support@solaxpower.it)

## PAKISTAN

---

 [service.pk@solaxpower.com](mailto:service.pk@solaxpower.com)



## AUSTRALIA

---

 21 Nicholas Dr, Dandenong South VIC 3175  
 +61 1300 476 529  
 [service@solaxpower.com](mailto:service@solaxpower.com)





## GERMANY

---

 Am Tullnaupark 8, 90402 Nürnberg,  
Germany  
 +49 (0) 6142 4091 664  
 [service.eu@solaxpower.com](mailto:service.eu@solaxpower.com)  
 [service.dach@solaxpower.com](mailto:service.dach@solaxpower.com)



## NETHERLANDS

---

 Twekkeler-Es 15 7547 ST Enschede  
 +31 (0) 8527 37932  
 [service.eu@solaxpower.com](mailto:service.eu@solaxpower.com)  
 [service.bnl@solaxpower.com](mailto:service.bnl@solaxpower.com)



## SPAIN

---

 +34 9373 79607  
 [tecnico@solaxpower.com](mailto:tecnico@solaxpower.com)

## BRAZIL

---

 +55 (34) 9667 0319  
 [info@solaxpower.com](mailto:info@solaxpower.com)

## SOUTH AFRICA

---

 [service.za@solaxpower.com](mailto:service.za@solaxpower.com)



**SolaX Power Network Technology (Zhejiang) Co., Ltd.**

Add.: No. 278, Shizhu Road, Chengnan Sub-district, Tonglu County,  
Hangzhou, Zhejiang, China  
E-mail: [info@solaxpower.com](mailto:info@solaxpower.com)

