

WOOD FIREPLACE

## BLOKK 70 BLOKK 90



version N



version V

For all updates visit [www.edilkamin.com](http://www.edilkamin.com)

## TABLE OF CONTENTS

---

Safety information	4
Introducing the range	5
General information (Technical data, Dimensions)	6
Installation	8
Regulator	20
Instructions for use	26
Maintenance	30
In the event of problems	31

---

*The original language of this manual is Italian*

2

The undersigned EDILKAMIN S.p.a. with head office headquarters at Via Vincenzo Monti 47 - 20123 Milan - Italy - VAT IT00192220192

Declares under its own responsibility as follows:

The below listed wood burning products comply with EU Regulation 305/2011 and the harmonized European Standard EN 13229:2001+A1:2003+A2:2004+AC:2006+AC:2007

Wood Fireplace trademark EDILKAMIN,  
called  
BLOKK 70 Dop 182  
BLOKK 90 Dop 187

Not all versions are available for all countries.

The liability of Edilkamin is limited to the product supply only.

---

Dear Sir/Madam  
Congratulations on choosing our product. Before you use it, please read this manual carefully, to get the best from your new appliance in total safety.

This manual is an integral part of the product. Please keep it for the entire life of the product.  
If you lose it, you can request a copy or download it from [www.edilkamin.com](http://www.edilkamin.com)

After unpacking the product, check the condition and completeness of the contents.  
In the event of error, immediately contact the retailer where the purchase was made, providing him with a copy of the warranty booklet and the sales receipt.

The appliance must be installed and operated in compliance with local and national law and European regulations. For the installation, and for anything not specifically indicated in the manual, observe local regulations.

The diagrams in this manual are illustrative; they do not always refer specifically to your product and are not binding in any way.

The product is uniquely identified by a number, the "counterfoil", which is indicated on the warranty certificate inside the product.

Please keep:

- the warranty certificate accompanying the product
- the purchase receipt given to you by the retailer
- the declaration of conformity given to you by the installer.

The warranty conditions are given in the warranty certificate accompanying the product.



The product's CE marking plate is located above the glass, under the casing, and can also be accessed once the product has been installed.

### SYMBOLS

Some parts of the manual use the following symbols:



#### CAUTION:

Read carefully the message to which this refers, as failure to do so may result in serious damage to the product and may endanger the safety of people using it.



#### INFORMATION:

Failure to follow these instructions could compromise correct product use.

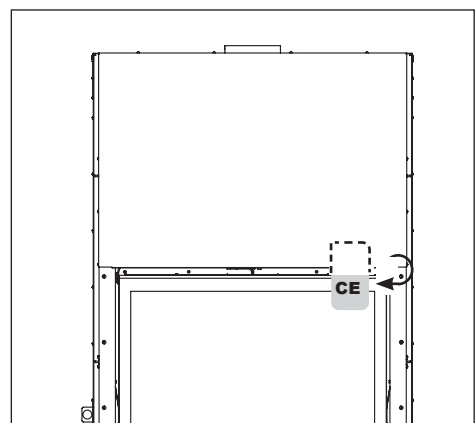

- Incorrect installations or improper maintenance causes safety risks, for which Edilkamin cannot be held liable.
- The product was not designed for use by people, including children, whose physical, sensory or mental capacities are reduced.
- The product was not designed for cooking.
- The product was designed to burn dry wood in the quantities and methods described in this manual
- The product was designed for internal use and in premises with normal humidity
- For the legal and standard guarantee, refer to the Certificate of Guarantee found with the product
- The product must be installed in premises where there is no danger of fire.
- In the event of fire, call the competent authorities
- Do not extinguish the fire with water jets
- The product must be kept in dry places and not exposed to bad weather.

The safety risks can be caused, among other things, by:

- contact with the fire and hot parts (e.g. glass and piping). **DO NOT TOUCH HOT PARTS** and, with the product off but hot, always use the glove. Otherwise you risk getting burnt
- use of unsuitable products for lighting (e.g. alcohol). **DO NOT LIGHT OR RE-LIGHT THE FLAME WITH LIQUID SPRAY PRODUCTS OR FLAMETHROWERS.** You risk getting seriously burned and causing damage to property and people.
- use of fuel other than dry wood. **DO NOT BURN RUBBISH, PLASTIC OR ANYTHING OTHER THAN DRY WOOD IN THE FIREPLACE.** You risk dirtying the product, fires in the chimney flue and causing damage to the environment.
- use of fuel different from the recommended fuel. **DO NOT OVERLOAD THE FIREPLACE.** There is a risk of deformation with risks for people in the event of attempted
- fixing up and irreversible changes to the colour of the paint on the metal parts. Edilkamin or the retailer cannot be held liable.
- cleaning the hot fireplace. **DO NOT EXTRACT HOT.** You risk compromising the extractor and, possibly, smoke in the environment
- cleaning of the smoke channel with various substances. **DO NOT CLEAN WITH FLAMMABLE PRODUCTS.** There is a risk of fires, back draft.
- cleaning of the hot glass with unsuitable products. **DO NOT CLEAN THE HOT GLASS WITH WATER OR SUBSTANCES OTHER THAN GLASS CLEANERS RECOMMENDED OR DRY CLOTHES.** There is a risk of cracks in the glass as well as permanent, irreversible damage to the glass
- deposit of inflammable materials under the safety distance indicated on this manual. **DO NOT REST LINEN ON THE Product DO NOT POSITION THE CLOTHES HORSE AT DISTANCES UNDER THOSE CONSIDERED SAFE.** Keep any form of inflammable liquid far from the appliance in use. There is a risk of fire.
- blocked opening of the air vents in the premises or air input. **DO NOT BLOCK THE AIR VENT OPENINGS OR BLOCK THE CHIMNEY FLUE.** There is a risk of a back draft in the room which could damage property and people.
- use of the product as a support or ladder (**DO NOT CLIMB ON THE PRODUCT OR USE IT AS A SUPPORT**). You risk damaging property and people.
- use of the product with the fireplace open. **DO NOT USE THE Product WITH THE DOOR OPEN.** For greater protection of the product, there is a spring that allows the product to close automatically.
- addition of fuel and door opening approaching the fire with flammable and loose clothing. **Do NOT** open the door or approach the glass with flammable, wide clothing whose ends could catch fire
- open the door with incandescent material exiting. **Do NOT** throw incandescent material out of the product. You risk a fire

Lastly, you are advised to take all normal precautions in relation to home heating. If in doubt, do not act on your own initiative, but contact the retailer or installation technician.



**USE ONLY WITH REFRACTORIES  
INSTALLED**

**The Blokk range shown in this manual is made up of several models**

**Blokk 70 N - Blokk 90 N**

Products for natural-convection air circulation

They cannot be equipped with fans nor can they be used to create air ducting systems

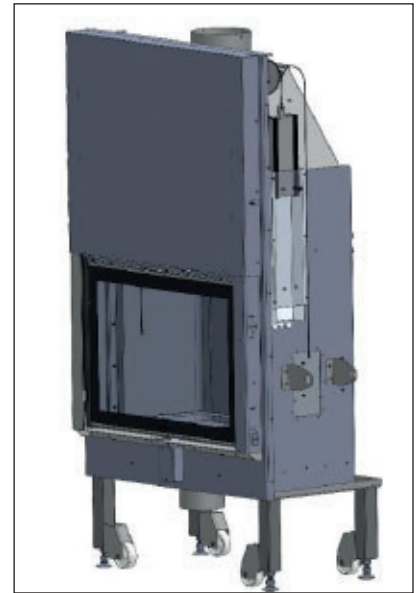

**Blokk 70 V - Blokk 90 V**

Products with incorporated fan **(V)**, which can be managed through the regulator with a remote control.



**TECHNICAL CHARACTERISTICS according to EN 13229** The data shown below refers to the actual installation and use and was taken during the certification phase by a notified body under the conditions specified by the standard. The results were obtained with the glass cleaning system closed, by the installer.

	<b>Blokk 70</b>	<b>Blokk 90</b>	
	Nominal power		
Power output	14,3	17,6	kW
Efficiency	81,4	81,1	%
Emissions CO 13% O <sub>2</sub>	0,07	0,09	%
Fumes temperature	252	238	°C
Minimum draught	11	12	Pa
Fuel consumption *	3,8	4,7	kg/h
Heatable volume **	375	460	m <sup>3</sup>
Smoke outlet pipe diameter	180		mm
Air intake pipe diameter	120		mm
Weight including packaging	306(N)/330(V)	383(N)/430(V)	kg
Energy efficiency class according to UE 2015- 1186 regulation (Class A+ +/G)	A+	A+	

\*A calorific value of 4.8 kW/Kg has been used to calculate consumption

\*\* The heating volume is calculated with the heat request of 33 Kcal/m<sup>3</sup> hour

The product can work safely even with greater draught.

Excessive draught could cause the product to switch off and/or lower its performance.

#### TECHNICAL DATA FOR THE DIMENSIONING OF THE FLUE

	<b>Blokk 70</b>	<b>Blokk 90</b>	
	Nominal power		
Temperature of fumes on exit from the discharge pipe	302	285	°C
Minimum draught	10	10	Pa
Fume flow capacity	12	13	g/s

Intermittent mode combustion device

**EDILKAMIN s.p.a. reserves the right to change the products at its discretion without notice.**

**Blokk 70/ Blokk 90 dimensions cm**

glass dimensions 70x51 (Blokk70\*)

glass dimensions 90x67 (Blokk 90)

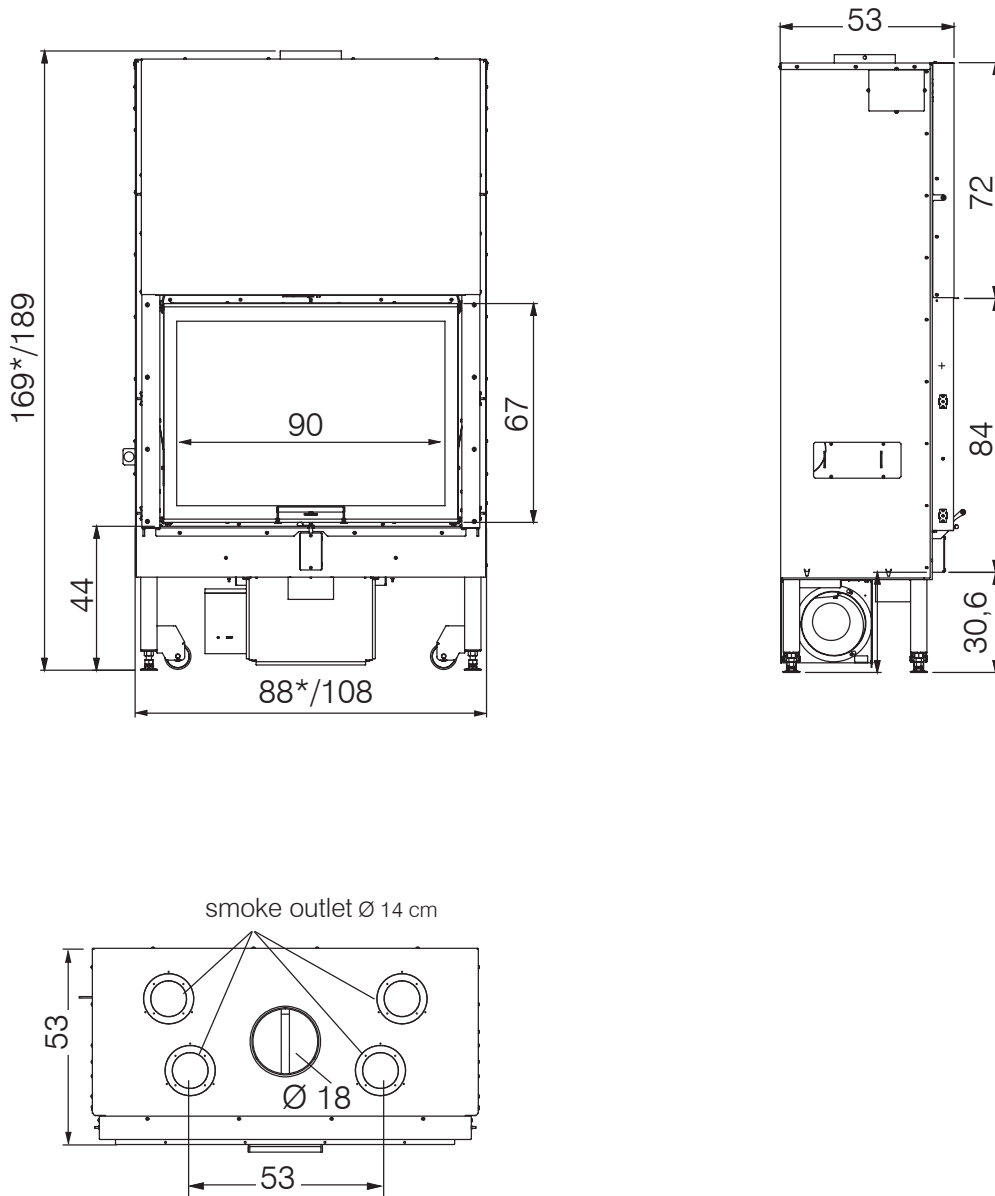

Blokk 70 \*/ Blokk 90 (version V)

**PREPARATION AND UNPACKING**

The materials composing the packaging are not toxic or harmful, therefore no particular disposal processes are required.

Storage, disposal and any recycling is the responsibility of the end user in compliance with the laws in force on the matter.



You are recommended to make each movement in a vertical position with suitable devices, paying attention to the safety standards in force.

Do not overturn the packaging and be cautious when assembling parts.

**DETACH THE PRODUCT FROM THE PALLET**

Detach the product from the pallet by loosening the screws (A) securing it to the latter and located on the feet. Remove the product from the pallet while being careful to protect the door and its glass panel from mechanical impacts which could damage them.

**PICK-UP POINTS FOR HANDLING**

The monobloc is equipped with four rings to facilitate its transport.  
Insert two tubes through the rings.



Make sure that the product remains balanced during handling.

**SHIFTING OF THE PRODUCT WITH WHEELS NEAR THE INSTALLATION POSITION**

The fireplace is equipped with FOUR wheels (B)  
Screw on the feet to use the wheels.

**FEET**

The feet are used to distance the fireplace from the floor and to level the hearth.  
They can be adjusted to maximum 10 cm.

Une fois la cheminée mise en place, repositionner les pieds.



USE THE WHEELS ONLY FOR SMALL MOVEMENTS DO NOT DRAG THE PRODUCT. THE FEET MAY GET DAMAGED.

USE THE WHEELS, after screwing the feet on



PLEASE NOTE

If the fireplace is not level there may be problems with the door's sliding movement.

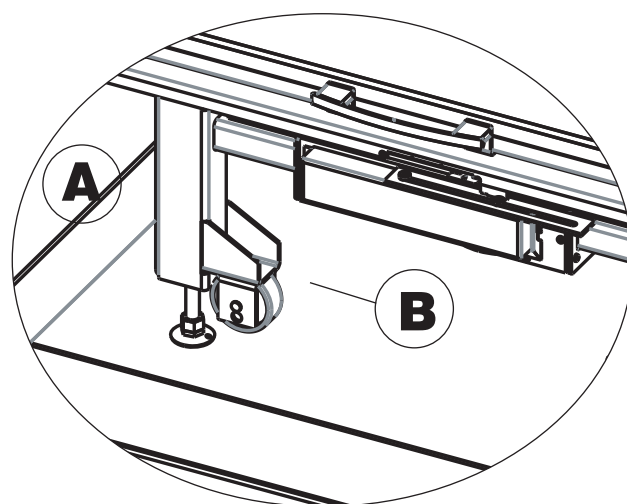

LOOSEN THE LOCKING SCREWS ON THE SIDE OF THE DOOR ONLY AFTER THE PRODUCT HAS BEEN POSITIONED. DO NOT SHIFT THE PRODUCT WITHOUT THE LOCKING SCREWS

**PACKAGING**

The packaging includes a useful inspection hatch to check the status of the product. On receipt, check and immediately notify the retailer of any anomalies.

The packaging comprises a single item containing the following:

Description	Number in the figure below	Quantity	Use
Fireplace		1	*
Side and rear refractory elements		5	
Anti-corrosion discs	(2)	2	
*R2 unions Ø 140 mm	(3)*	2	for ducting in the version without ventilation kit
Handle for hatch lifting	(4)	1	can be used either as a fixed handle (by fastening it with the screws) or as a detachable handle, using the relevant bushes.
*Side cover of the casing	(5)*	2	to be screwed on once the chimney has been positioned and the lifting brackets have been removed. Tighten the (4+4) screws and close the opening with the side cover of the casing.
*Air box cover	(6)*	1	To be used only if it is not possible to duct the combustion air inlet."
*Ø 200 mm flange for air box	(7)*	1	
*Bag with 4.2 x 9.5 screws	(8)*	22	

**\* N.B.: only for ventilated versions, otherwise not present**

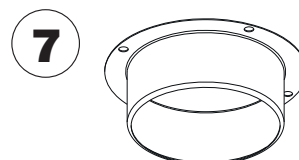
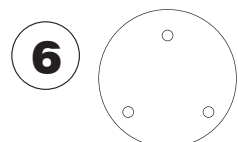
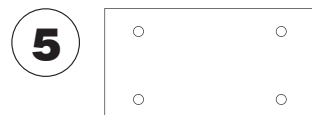
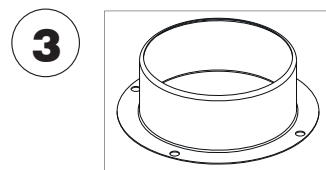
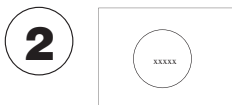

“LOOSEN THE LOCKING SCREWS ON THE SIDES IN ORDER TO LIFT THE DOOR  
LOOSEN THE SCREWS ONLY AFTER THE PRODUCT HAS BEEN POSITIONED  
DO NOT SHIFT THE PRODUCT WITHOUT THE LOCKING SCREWS”

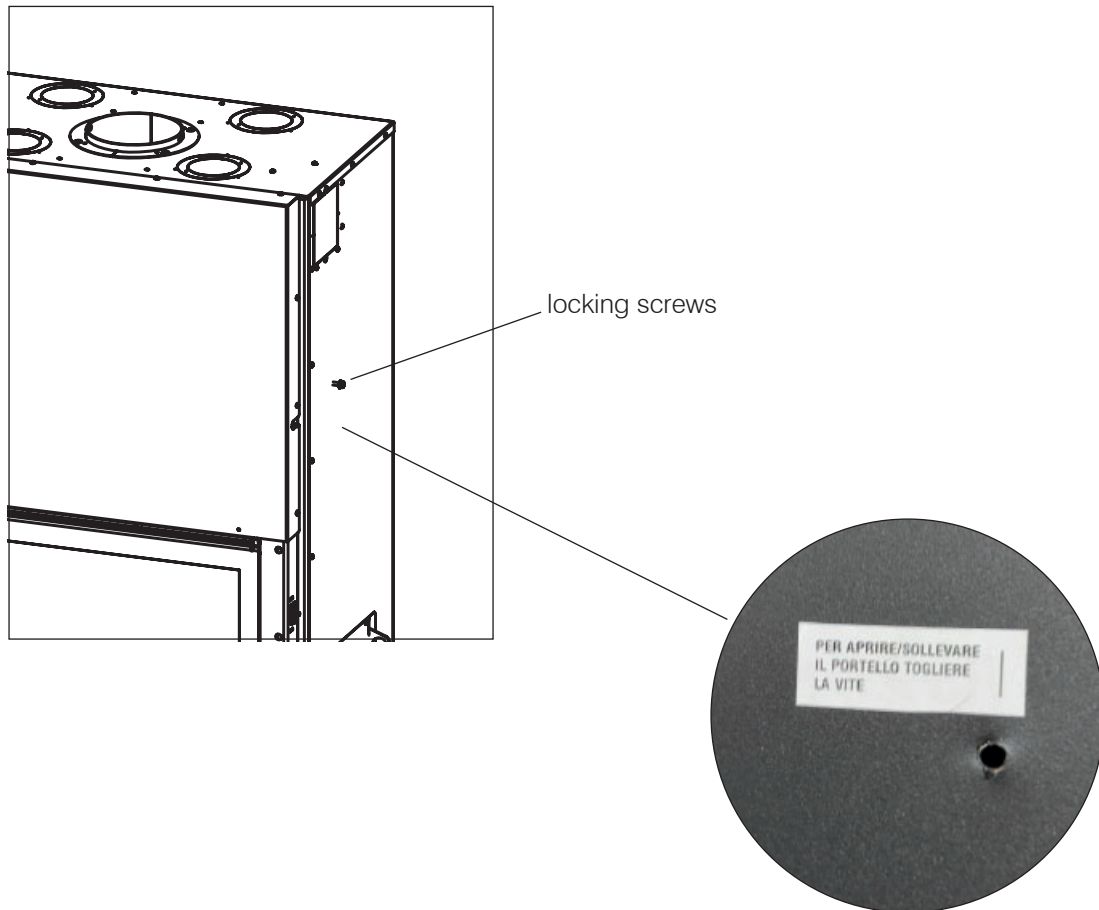

**INTERNAL REFRACTORY ELEMENTS**

Assembly sequence for REFRACTORY ELEMENTS

- 1) Position the LH SIDE element
- 2) Position the BOTTOM element
- 3) Position the RH SIDE element
- 4) Position the deflector (E)

**USE ONLY WITH REFRACTORIES INSTALLED**

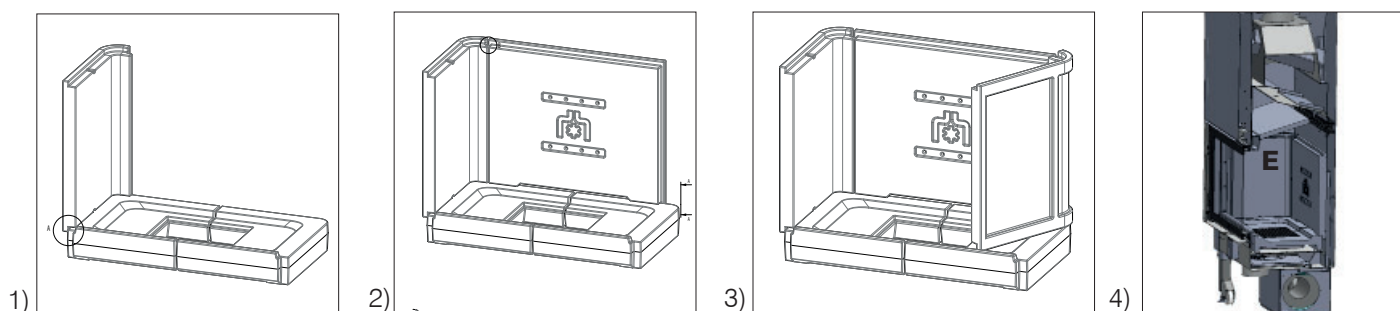

**ADJUSTABLE SHUTTER**

In low draught conditions, the smoke flow can be adjusted using the adjustable shutter (34x13 cm) shown in the adjacent figure.

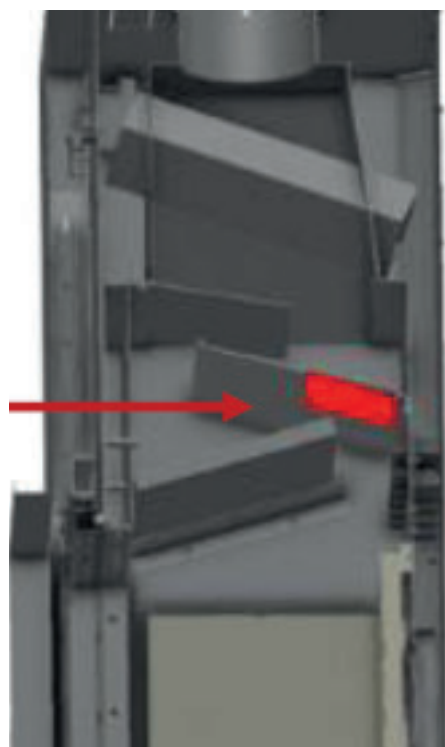

The smoke outlet diameter does not match the chimney system diameter, which must be sized accordingly.

**SELF-CLOSING DOOR**

The fireplace is delivered with the door balanced, that is, it does not drop automatically once raised. To make the door self-closing, one or more plates (P) must be applied to the inner frame for the door.

without plates (standard)	with plates (added during the installation phase)
NOT self-closing	self-closing

INTERNAL VIEW OF THE PLATES ON THE DOOR FRAME

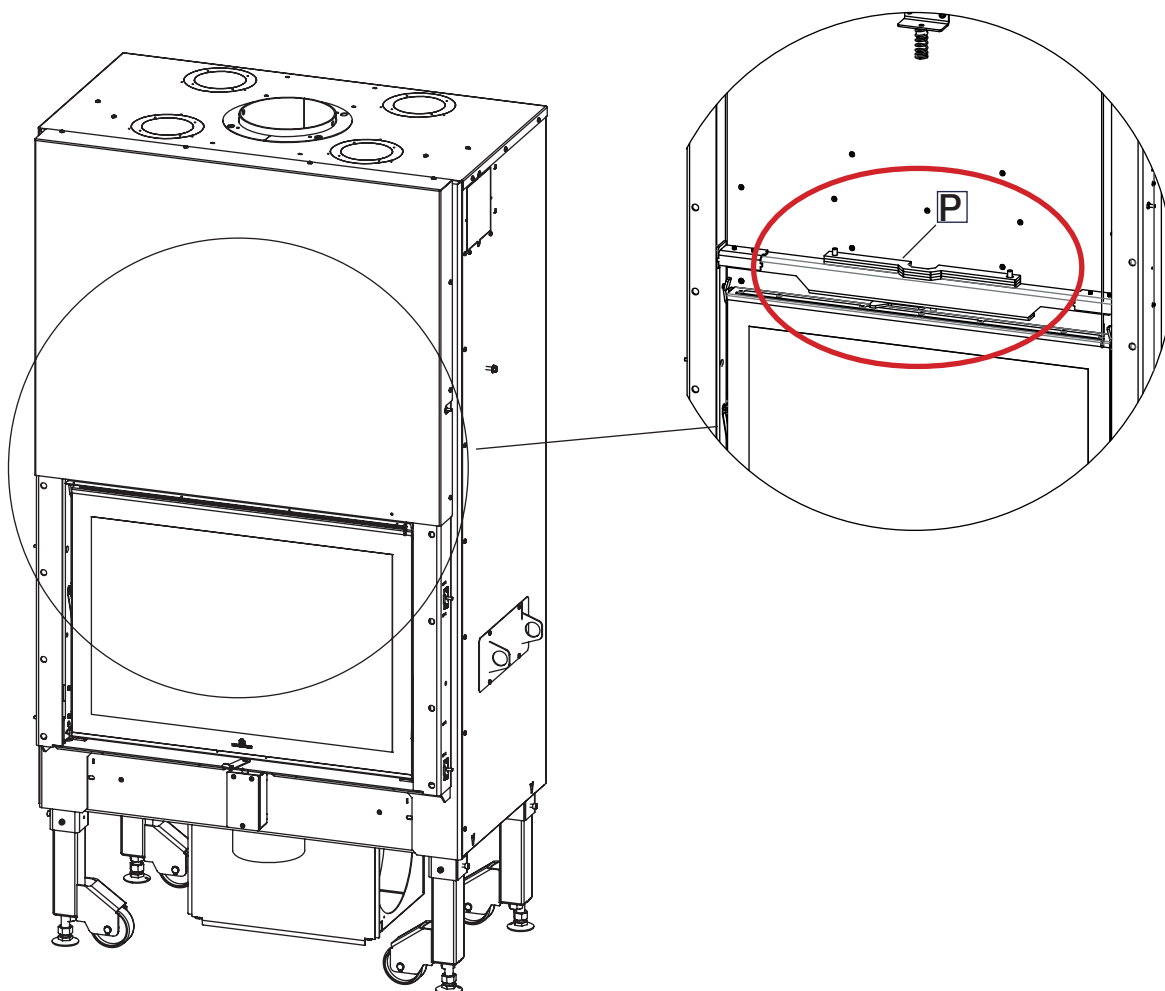

**INTRODUCTION ON INSTALLATION**

Remember that:

- the product must be installed by qualified staff who can issue a Declaration of Conformity
- all the local and national laws and the European Standards must be met for installation and use of the product.
- In the event of installation in apartment blocks, ask the administrator’s opinion beforehand.
- 

We give some general instructions below, however these do not obviate the need to comply with local regulations and do not affect the installer’s liability for the installation.

**Checking the suitability of the installation premises**

- The volume of the room must be over 40 m<sup>3</sup>
- Installation is not permitted in bedrooms, bathrooms or premises with other products that take in air for combustion of the same premises or in premises with an explosive atmosphere. Any extractor fans, if working in the same environment or space in which the product is installed, can cause draft problems.
- In Italy, check compatibility pursuant to UNI 10683 and UNI 7129 in the presence of gas products.
- The floor must be able to support the weight of the product and the accessories.



When installing the product, leave enough space to allow easy access for cleaning the product and the chimney system.



**Electricity lines**  
There must be no electricity lines in the walls or ceiling of the fireplace installation area.

**Protection from heat and safe distances**

All the surfaces of the building adjacent to the product must be protected against heating. The insulation measurements to implement depend on the type of surface present.

“Check on the chimney system’s data plate the safety distances to be kept in the presence of combustible materials and the type of insulating material to be used.”

The product must be installed in accordance with the following safety instructions (dimension mm):

<b>Blokk 70</b>
Rear = 200 Sides = 300 Front = 800

<b>Blokk 90</b>
Rear = 200 Sides = 300 Front = 800



**FOR “N” VERSION PRODUCTS**

THE WALL BEHIND AND TO THE SIDE OF THE FIREPLACE MUST BE INSULATED.  
THEY ARE PRODUCTS WITHOUT CASING

## CHIMNEY SYSTEM

### (Smoke channel, chimney flue and chimney stack)

This chapter is drafted according to the European Standards EN 13384, EN 1443, EN 1856, EN 1457. The installation technicians must take into consideration these and any other local standards. The manual should in no way be considered a replacement for the laws in force.

The product must be connected to a suitable smoke discharge that guarantees completely safe evacuation of the smoke produced by combustion.

Before positioning the product, you need to check the chimney flue is suitable.

### SMOKE CHANNEL, CHIMNEY FLUE

The smoke channel (pipe that connects the smoke outlet of the fireplace with the chimney flue inlet) and the chimney flue must, along with other legal provisions:

- receive the discharge for a single product (multiple product discharges are not permitted together)
- have a mainly vertical development
- no section should have a reserve slope
- have an inner section preferably circular and however with a ratio between sides lower than 1.5
- complete the roof with the appropriate chimney stack: direct discharge is forbidden on walls or towards closed spaces, even if outdoors
- be created with materials with a fire reaction class A1 pursuant to UNI EN 13501 or similar national standard
- be appropriately certified, with an appropriate fireplace plate, if metal
- keep the initial section

The chimney system must be sized by an expert in accordance with the regulations in force.



The smoke outlet diameter does not match the chimney system diameter, which must be sized accordingly.

**THE SMOKE CHANNEL**

- if in metal must have a CE marking (EN 1856-2) or similar national law;
- cannot be in flexible metal material
- to check the flow, a shutter is advised for draft over 25 Pa

**THE CHIMNEY FLUE:**

- must have a draft capable of creating negative pressure ideally around 12 Pa. Lower drafts can cause leaking smoke if the door is open; higher values tend to generate fast combustion by reducing the yield
- must be correctly sized to meet smoke evacuation (EN 13384-1)
- must preferably be insulated, in steel with a circular inner section. If rectangular, the inner edges must have a radius under 20 mm and a ratio between between the inner dimensions <1.5
- normally have a minimum height of 3-4 metres
- maintain a constant section
- be waterproof and thermally insulated to guarantee draft.
- preferably create a collection chamber for unburned fuel and any condensate
- be at least category T400, with an adequate resistance to soot firelf pre-existing, it must be cleaned to avoid risk of fire.

**EXTERNAL AIR INTAKE**

To re-integrate burnt oxygen during product functioning, you need to have an installation premises suitable for the external air intake.

Once the product is faced, the Ø 14 cm pipe (A) must be connected so that it does not remain closed in the facing and takes in air from the air intake.

In accordance with local regulations, the air intake can be mounted outside or in suitable rooms not subject to depression.



**USE ONLY WITH REFRACTORIES  
INSTALLED**



Infiltration of water from condensation through the flue must be strictly avoided. If necessary, an anti-condensate ring should be installed. Ask your chimney sweep for details.  
Damage caused by water from condensation is excluded from the warranty.

**EXTERNAL AIR INTAKE**

To re-integrate burnt oxygen during product functioning, you need to have an installation premises suitable for the external air intake.

“WE SUGGEST CONNECTING THE PRODUCT’S AIR INTAKE DIRECTLY WITH THE OUTSIDE PART OF THE CLADDING.

THIS IS ESPECIALLY IMPORTANT FOR VENTILATED VERSIONS TO AVOID INTERFERENCES WITH THE FAN”

**For Blokk 70, pass the optional pipe connecting the combustion air intake above the wheel support.**

**INSTALLATION EXAMPLE**

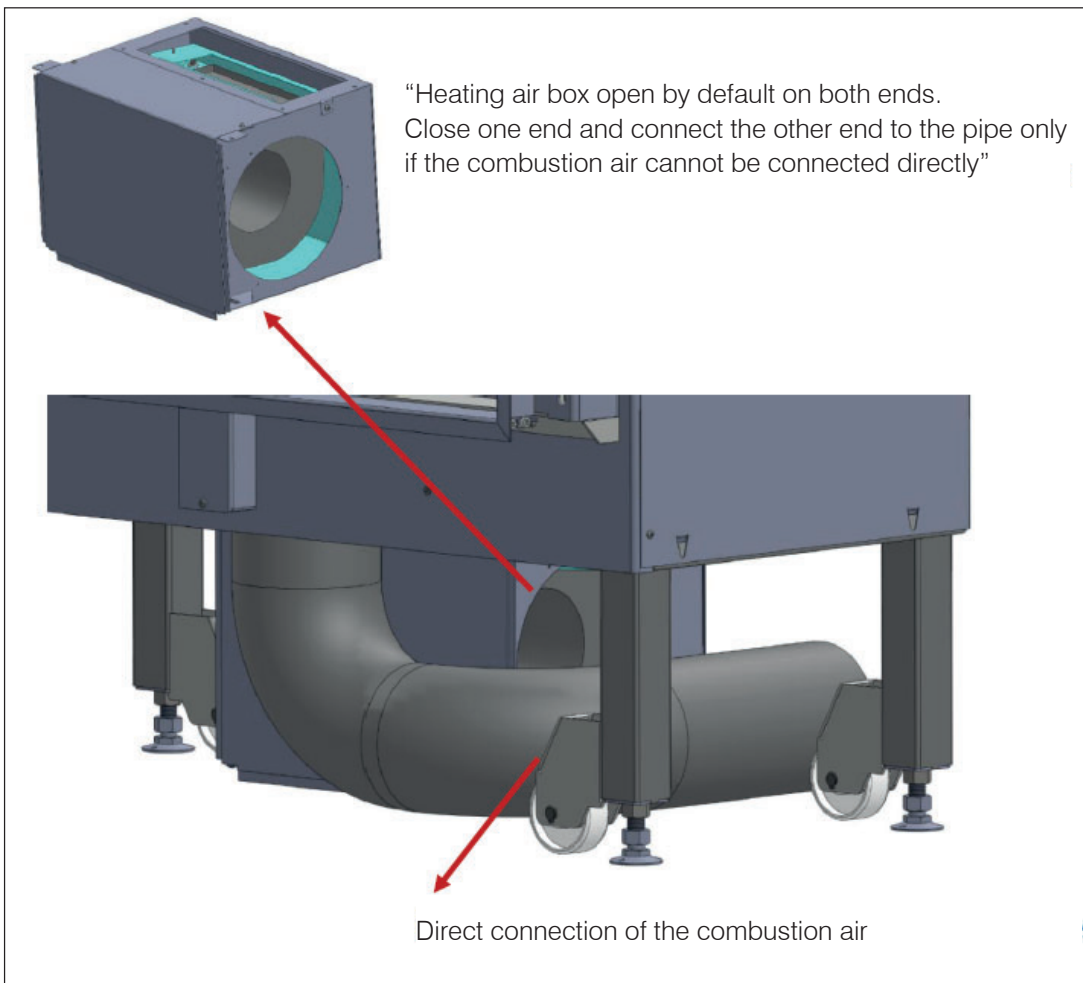
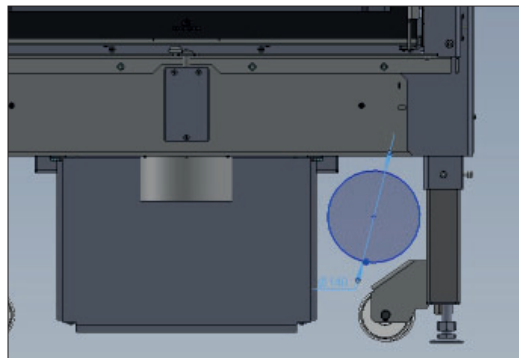

**Blokk 70 V / Blokk 90 V**

They are equipped with a fan on the bottom side, which can be accessed from inside the combustion chamber.

They are equipped with a regulator and a remote control.

Position the regulator in a cool zone to prevent overheating of the circuits.”

In some countries, under special conditions, multiple flue installations are allowed. According to regional regulations, additional safety installations are required when connecting multiple flues. Please contact your local chimney sweeper/ technician for further details and information.

**Blokk 70 V / Blokk 90 V****CONTENTS**

- A NTC probe for checking the temperature ( $b=3435$  10kOhm at 25°C) to be placed on the air vent
- Fixing screws for wall-mounted boxes
- Remote control
- A regulator with support for wall built-in installation on Gewiss/Vimar/Bticino/Ave 504 boxes. Place far from sources of heat
- A 2-meter cable for connecting the controller to the motor.

Value/Element	Rated
Mains power supply	230 VAC
Frequency	50/60 Hz
Operating temperature	0° C-85° C
5x20 glass fuse	2A(T)-250V ~

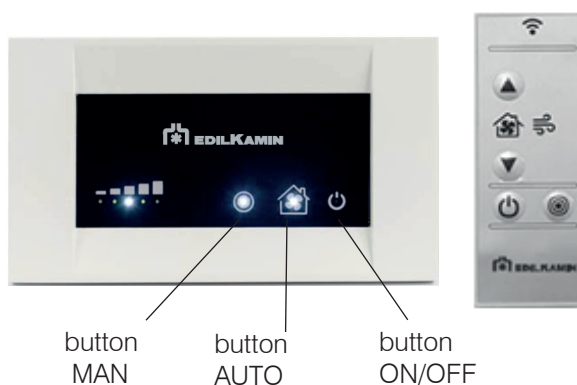
**“SWITCH-ON**

The regulator can be switched on using the ON/OFF button and the ON status will be signalled by the switching on of the LED inserted in the AUTO button or in the MAN button.

When it switches on, the board will be in the AUTOMATIC operating mode

**MANUAL OPERATION**

The fan rotates independently from the chimney's temperature and the user can choose the fixed/desired speed. The Manual operating mode can be selected with the MAN button and is signalled by the LED inserted in the button. In this mode it is possible to set 5 fixed ventilation speeds: V1, V2, V3, V4, V5.

The speed increases or decreases cyclically by pressing the button and does not depend on the temperature measured by the probe. (V1 2 3 4 5 .... 1 2 3 ....)

**AUTOMATIC OPERATION**

The fan starts only once the default pre-set temperature ( $>35^{\circ}\text{C}$ ) is reached, and the speed is adjusted automatically on the basis of the temperature measured by the probe connected to the regulator.

The Automatic operating mode can be selected with the AUTO button and is signalled by the LED inserted in the button.

In this mode, the ventilation speed is adjusted exclusively on the basis of the temperature measured by the probe.

The fan is powered at V1 = Minimum Speed = Temp.  $\Rightarrow 35^{\circ}\text{C}$

The fan is powered at V5 = Maximum Speed = Temp.  $\Rightarrow 55^{\circ}\text{C}$

The fan speed varies between V2 and V4 in steps at the intermediate temperatures  $\Rightarrow 40^{\circ}\text{C}$  and  $\Rightarrow 50^{\circ}\text{C}$

**SWITCHING OFF**

The regulator can be switched off using the ON/OFF button and the OFF status will be signalled by the switching on of the LED inserted in the button.”

**FOR THE INSTALLER ONLY****- "Fan activation every 10' (Kick)**

This function can be activated/deactivated with a jumper to be mounted on the device before the final installation of the regulator. The function is deactivated by default.

Jumper towards the inside of the board = function deactivated (default)

Jumper towards the outside of the board = function active

If the temperature is < Minimum Temp. and the fan is switched off, every 10' the fan is activated for 10 seconds.

**- Blackout**

In the event of a power outage, when the regulator's operation is restored it restarts in the same mode it was in before the blackout.

**- Maximum Speed Limiting Function in Automatic Mode**

Pressing the AUTO button for >5" allows for limiting the maximum operating speed in the Automatic mode (default Max V = V5). It has no effect in the manual mode.

Pressing the AUTO button for more than 5" causes all the LEDs of the bar to flash, while pressing the button again cyclically causes the "V1 2 3 4" -- "V1 2 3" -- "V1 2 3 4 5" LEDs to flash

Releasing the button and confirming the choice with the MAN button inhibits the speeds which will appear OFF on the LED bar.

To restore the default settings, repeat the operation and set all the LEDs to ON."

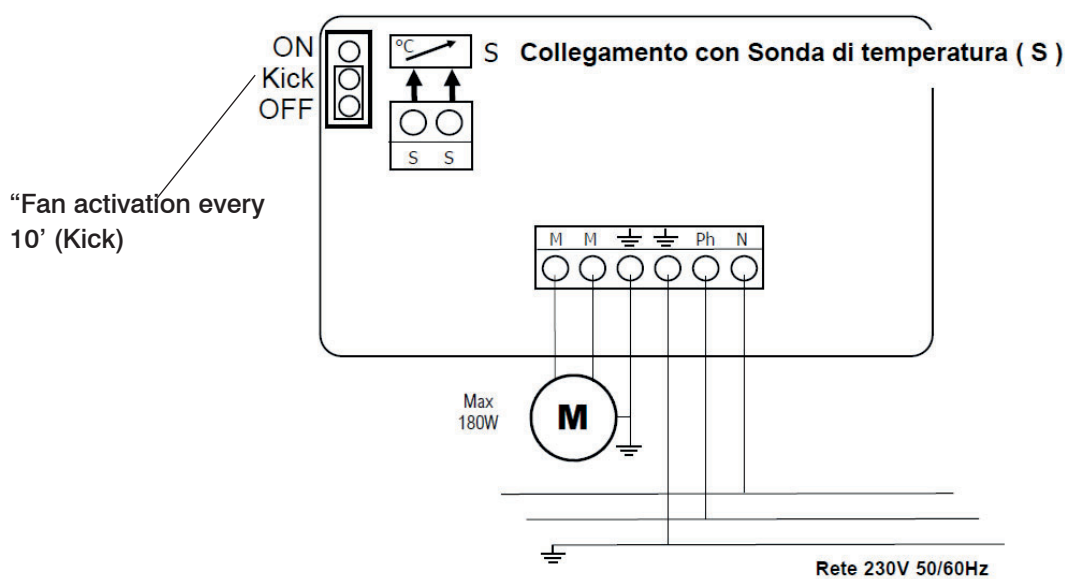
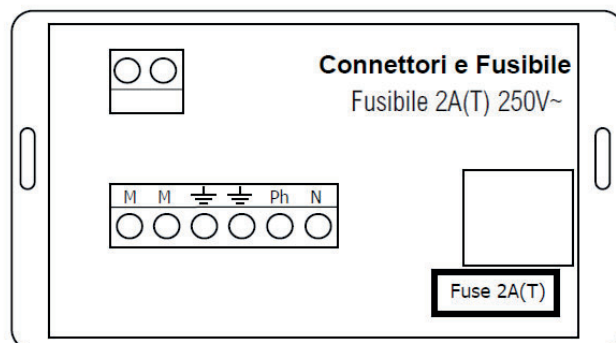
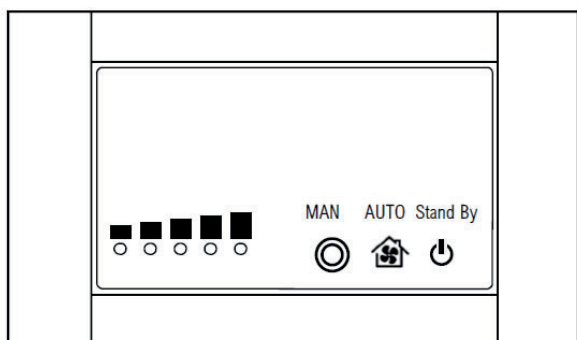

### Inputs / Outputs to the connectors

- L Power supply live 230 V ~50/60 Hz
- N Power supply neutral 230 V ~50/60 Hz
- Earth from mains
- Earth to motor (M)
- M Motor (M) power supply max. 150 W
- M Motor (M) power supply max. 150 W
- S Probe (S) connection
- S Probe (S) connection
- K In position as shown in the drawing disabled (by default)
- K In high position enabled

### Facings, gather hood and vents

Face the product only after having completed the following steps:

- connection of the product to the smoke outlet and air intake;
- inspection of the product when hot;
- check to verify whether the product is levelled.

The installer must implement all the installation good practices and take all the necessary precautions against overheating and fire.

In particular:

- if a plinth is constructed beneath the hearth level, it must include a suitable slot for the passage of recirculation air from the room;
- wooden parts must be protected with fireproof panels, which must not be placed against one another but spaced at least 1 cm apart to enable air to flow and prevent heat build-up. The gather hood can be made with fireproof panels, plasterboard or gypsum slabs; during construction, the hot air ducting kit must be mounted as described above.

The interior of the gather hood should be aerated by exploiting the flow of air coming from below (the space between the door and mantel) which convective currents will cause to exit from the grille on top, thus allowing heat recovery and preventing undue overheating.

In addition to that mentioned above, take into account the regulations in force in the relevant country concerning “insulation, finishes, facings and safety recommendations”.

### Vents

These must be strictly installed on the front: one beneath and one above the fireplace's opening. The product is not supplied with.



Verify that the product works properly before applying the cladding.

- In particular, check the following:
- Sliding elements
- Cabling

All materials used inside the coating must be able to withstand high temperatures and be flame retardant.



**USE ONLY WITH REFRACTORIES  
INSTALLED**

**FOR INSTALLER**

Door movement can be adjusted as shown below.

**INLET SURROUND:**

The inlet surround is an optional accessory.  
It fills in the gap remaining between the firebox's frame and the cladding itself.  
If purchased, it is sold in a single package.

**TEMPLATE FOR GATHER HOOD:**

Optional, to position before finishing cladding and frame for its placement.

Internal dimension:

**Blokk 70:** cm 72x55h

**Blokk 90:** cm 92x71h

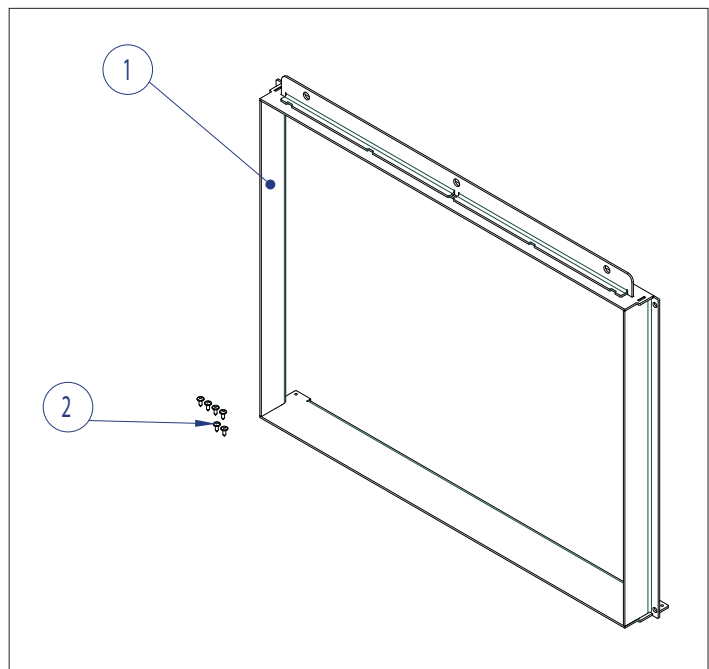

- **VERTICAL-OPENING AND BOTTOM-HUNG DOOR FOR CLEANING**

The door unlocking adjuster lever **(LR)** is located on the top part of the door;

The levers **(L)** to open the door with the bottom-hung system are to the right and left of the door.

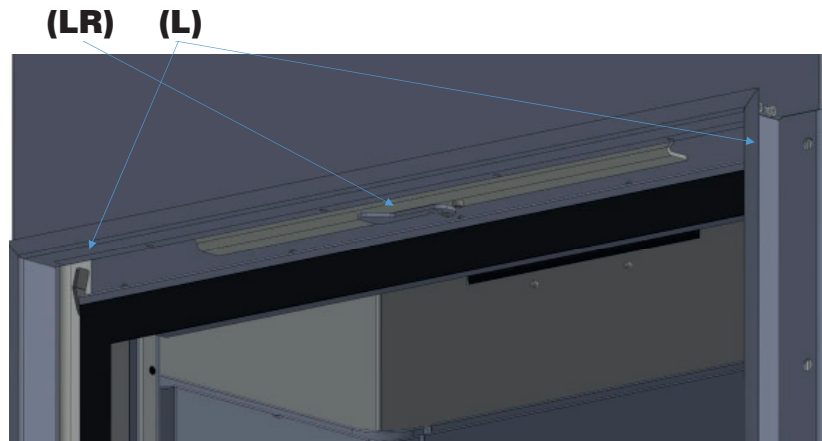

- **OPENING THE DOOR WITH VERTICAL MOVEMENT (LOCK LEVER LR at the TOP)**

Use the handle (detachable), which is fixed with screws.

- **BOTTOM-HUNG DOOR OPENING**

To open the door with the bottom-hung system, adjust the levers **L** to the right and left of the door



**AIR CONTROL**

Shifting the air limiter lever allows for regulating the amount of combustion air entering the combustion chamber and post combustion

Description	Effect
<b>Position 1</b> Ignition / maximum power	Primary air sent entirely to the combustion chamber plus turbo air (all to the RH)
<b>Position 2</b> Intermediate	Primary air completely open
<b>Position 3</b> Intermediate	Primary air half
<b>Position 4</b> Ember maintenance	"Post-combustion air only All passages for the primary combustion air are closed (all to the LH)"

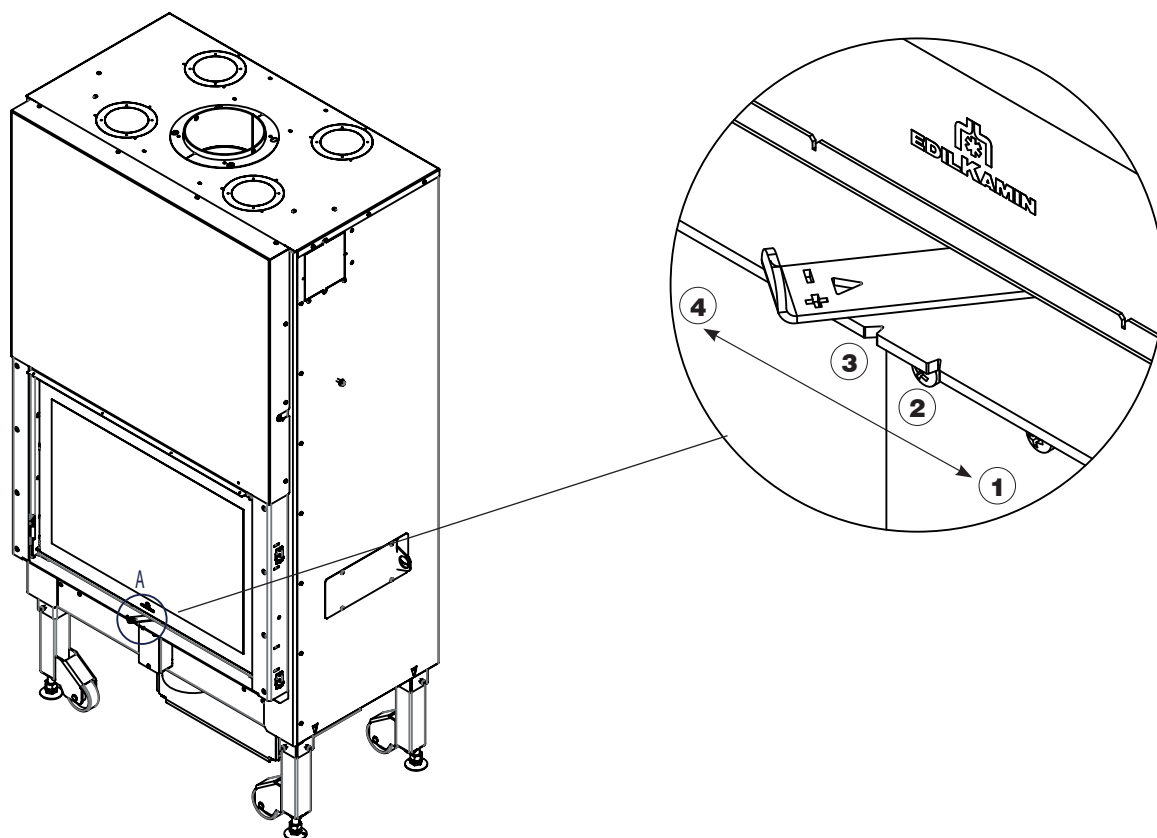

**FUEL**

The product was designed to burn wooden logs or sawdust briquettes.

Use dry wood logs (max. humidity 20%) Use logs The use of damp wood would cause the product and the flue to get dirty, the risk of smoke and a lower yield than that declared. Each type of wood has different characteristics that also influence combustion yield.

The data outlined on this manual are with wood used during certification.

In general wood can have a heat of combustion up to 4.5 kWh/kg while cut fresh it has heat of combustion around 2 kWh/kg

In general, beech or elm is recommended, or however class A1 wood according to UNI EN ISO 17225-5

Attention to prolonged use of wood with aromatic oils (e.g. eucalyptus). Cast iron parts can deteriorate

Use the recommended quantities of wood:

Overloading causes overheating, resulting in damage:

- possible deformation of the inner parts;
- possible irreversible changes to the colour of the paint on the metal parts for which Edilkamin or the retailer cannot be held liable.

To respect the environment and safety, do NOT burn, among other things: plastic, varnished wood, coal and bark waste. Do not use the product as an incinerator.

Use of these fuels also nullifies the guarantee.

TO OBTAIN THE RATED POWER, FOLLOW THE INDICATIONS ON THE TECHNICAL CHARACTERISTICS PAGES

**First switch on phases**

- Ensure you have read and understood the content of this manual
- Remove all the inflammable parts from the product (manuals, labels, etc.). In particular remove any labels from the glass. If they melt, they would irreversibly damage the glass.

For initial switch on of the fireplace, always use the smallest logs. Use larger wooden logs to raise the fire. Place the wood on the combustion grille.

**NOTE**

Always locate the wood deep in the fireplace, almost in contact with the rear wall, so that even if they slide they won't come in contact with the glass.

**Lighting a cold fireplace**

1. Check the existing ash bed is not too high. If the ash bed is too high, there is a danger of opening the door of the fireplace to add wood and possible brazier fragments fall out of the fireplace.
2. Position the adjustment lever of the valve in the "total opening" position. The air for combustion will flow intensely to the wood in the fireplace, to quickly reach good combustion.
3. place the wood in the fireplace without excessively squashing it in. Position a firelighter between the wood logs and light. Never use materials such as petrol, alcohol and similar to switch on.
4. At this point, close the door and monitor it for a few minutes. If the fire should extinguish, slowly open the door, re-position another firelighter between the logs and light again.

**Lighting a hot fireplace**

When should wood be added? When the fuel is almost completely consumed to embers. With the glove, slowly open (to avoid formation of vortices that can cause smoke to exit) the door. Add the desired wood to the fireplace, locating it on the existing embers (within the quality limits indicated in the technical table).

Product functioning changes with the chimney flue draft and adjustment of the air valve in combustion.

**Functioning with initial low draft**

To extract air for combustion and discharge the smoke, the fireplace needs a draft to be exerted on the chimney flue.

If the draft is weak, initially light a "starter" fire using small sized lighting material.

Once the correct draft is restored, you can add the fuel.



Employer toujours le gant en dotation pour les parties chaudes.  
Avoid direct contact with hot parts.

**“EXPANSIONS**

As with all appliances, a wood appliance heats up and cools down during the various operating stages. This implies normal expansion movements.

These expansions may cause slight settling noises that cannot constitute grounds for complaints.”

**“ODOURS**

On first ignition, there may be a slight smell of paint, which will disappear in a short time.”

**NOTES ON REFRACTORY MATERIAL**

The inner refractory material was designed to resist normal use.

Its cleaning is ensured by good combustion. The main damage to refractory material comes from:

- accidental knocks
- use of firelighters which are not ecologically loading
- wood beyond the recommended amount
- use of fuel other than that recommended

Edilkamin or the retailer cannot be held liable for damage caused as described above

**NOTE:**

The black refractory elements are enamelled, therefore they have a natural crackle effect and dull surface that cannot be regarded as defects.

### **Cleaning the glass**

#### **Open the product with the bottom-hung door, as shown previously (unlock the levers to the sides of the glass)**

You can use specific products to clean the glass (see our Glasskamin pricelist).

Do not spray the product on painted parts or the seals of the door. An alternative to the product is a rag soaked in a bit of white ash and a piece of newspaper. Attention, ensure there are no abrasive elements in the ash that could scratch the glass.



Ceramic glass installed on the products can resist heat up to approx. 750°C and is tested and controlled before and after assembly to check for the presence of cracks, bubbles and blowing.

The glass, despite its high resistance to temperature, is however a fragile element and therefore you are advised to move the door cautiously without banging or forcing it. Glass, since it is not flexible, can break.

### **Cleaning the external parts**

The covering must be clean without using aggressive detergents. Do not wet with cold water when the covering is hot because the thermal shock could cause damage.

### **Cleaning the chimney flue**

This should be carried out before the use season and each time you note a layer of soot and tar has formed inside, a substance that is easily flammable.

Scale, in the presence of high temperatures and sparks, can catch fire with serious consequences both for the chimney flue and for the home. You are therefore advised to clean at least once a year.

### **Ash removal (only with the fireplace off and cold)**

Remove the ash grille and pull out the tray.

Remove the ash using a scoop or ash cleaner.

Place the removed ash exclusively in non-combustible containers; bear in mind that the residual embers may still re-ignite 24 hours after the last combustion.

**SEASONAL MAINTENANCE by authorised technician**

This consists of cleaning the stove inside and out.

Seasonal maintenance should be performed by a qualified technician in accordance with the national and local regulations.

**If the product is used intensively, it is recommended to clean the smoke duct and passage every 3 months.**

You should clean the chimney system at least once a year (check local regulations for details).

If you fail to regularly clean and inspect the system, there is an increased risk of the chimney pot catching fire.

**REPAIRS**

To be performed only by Edilkamin technical assistance centres/authorised distributors. The names of Edilkamin technical assistance centres (TAC) and official, authorised distributors are available ONLY at [www.edilkamin.com](http://www.edilkamin.com)

**SUMMER SHUTDOWN**

During the period of disuse, keep the doors, hatches and lids closed.

In particularly humid areas, it may be necessary to disconnect the air intake and fume connector.

**SPARE PARTS**

For any spare parts, contact your dealer or technician. The names of Edilkamin technical assistance centres (TAC) and official, authorised distributors are available ONLY at [www.edilkamin.com](http://www.edilkamin.com)

Using non-original spare parts may damage the appliance and relieves Edilkamin of all liability for any resulting damages. This also invalidates the warranty on the basis of tampering.

Do not make unauthorised modifications.

**DISPOSAL**

At the end of its service life, dispose of the product as required by regulations.

**IN THE EVENT OF PROBLEMS****1) In case of smoke leaking from the fireplace hearth, check if:**

Installation is correct (smoke channel, chimney flue, stack, air intake). The wood used is dry. The door was opened too quickly

**2) In the event of uncontrolled combustion, check if:**

The seals of the fireplace are intact:  
The door of the fireplace is closed properly.

**3) If the glass gets dirty quickly, check if:  
The wood used is dry.**

However, consider that after a few hours of work, it is normal for a light layer of soot to form on the glass.

**4) If the chimney flue catches fire** or you need to suddenly extinguish the fire lighting in the fireplace:

- if possible, in safe conditions, remove the ash and brazier using tools and only touch metal containers with fireproof gloves.
- in the event of a fire, ask the authorities for help

**5) In case of odours, check if:**

If first switch on: in this case a paint smell is normal.  
If the product is dirty or dusty

**If you cannot solve the problem, contact the retailer or, in countries where present, the authorised Technical Support Centre.**

**The guarantee is only valid if the product defect is proven.**

**DISPOSAL**

At the end of its service life, dispose of the product as required by regulations.







The names of Edilkamin official, authorised technical assistance centres (TAC) and distributors are available ONLY at [www.edilkamin.com](http://www.edilkamin.com)



[www.edilkamin.com](http://www.edilkamin.com)

cod. 942127-GB 07.22/D