

Garden sauna

SCALA Large

459 x 313 x 272 cm

ASSEMBLY INSTRUCTIONS
English



EN

DE

FR

IT

NL

Table of Contents

1. Preparing for installation	3
1.1. Important note	3
1.2. Maintenance and cleaning	4
1.3. Foundation	4
1.4. Anchoring the outdoor sauna	5
1.5. Disposal	5
1.6. Tools required	6
1.7. Parts list	7
2. Floor plan/foundation	11
3. View/dimensions	12
4. Assembling the cabin	13
4.1. Assembling the base frame	13
4.2. Installing the floor substructure	13
4.3. Assembling the cabin walls	13
4.4. Installing the floor	13
4.5. Installing the interior roof	13
4.6. Installing the benches and backrests	13
4.7. Installing the windows and doors	14
4.8. Fit the skirting boards	14
4.9. Ventilation slit installation	14
4.10. Installing the outer roof	14
4.11. Installing the terrace	14
4.12. Installing the corner strips and ventilation grille	14
4.13. Installing the screen elements and roof supports	14
Assembly illustrations (after last language)	15

1. Preparing for installation

Read these assembly instructions carefully and keep them within reach, so that you can look up product information at any time.



These assembly instructions can also be found in the downloads section of our website: www.sentiotec.com/downloads.

1.1. Important note

- Check with your local planning authority (municipal office, magistrate) with respect to the building regulations and load standards.
- A solid concrete foundation is important for the durability as well as the safety of your outdoor sauna. We recommend having the foundation laid by a specialist.
- The anchoring of the outdoor sauna is the responsibility of the customer. No warranty in the event of damage.
- The outdoor sauna is delivered by lorry (also possible by semi-trailer truck). Access to the unloading area must be ensured.
- Before you begin work, check the parts list to ensure that all the individual parts have been delivered. If you discover any missing parts, notify your dealer within 14 days of receiving the sauna cabin.
- Keep the delivery note, the invoice and the assembly instructions in a safe place in case of any questions.
- You need an assistant for the installation.
- All screw fittings must be pre-drilled.

EN



Attention!

The electrical connection may only be performed by a qualified electrician or similarly qualified person.

- The roofing felt included in the scope of delivery serves as an initial roofing. We also recommend covering the roof with bitumen shingles, sheet metal or a suitable foil.
- Wood is a natural product that can swell, shrink or warp, despite good storage. For this reason, some force may be necessary during the installation.

- The wood of the outdoor sauna is untreated. To increase the life expectancy, we recommend painting the outside with a suitable paint to protect the wood.
- The inside of the wooden parts used must not be treated with any paint.

1.2. Maintenance and cleaning

- The sauna should be cleaned inside with a damp cloth. Only use warm water – no cleaning products.
- We recommend heating the cabin once a month if the sauna is not used for a long time.



Pitch pockets are not grounds for return, since they can always appear in spruce wood and the depth at which they lie cannot be detected during the sorting-out process.

If these are just under the surface, heat can cause them to soften and “bleed”.

The leaking pitch can be removed with a rag soaked in acetone. If only droplets of pitch occur, allow these to harden and then carefully scrape them off with a knife.

1.3. Foundation

The following foundation elements have proven themselves in practice:

- Foundation slab (base plate)
- Strip foundation

For both types, a foundation that is absolutely flat and load-bearing must be ensured. Only then can the assembly of the outdoor sauna be ensured without any difficulties and with a precise fit.

We recommend using tar tape between the base wood and the concrete to prevent moisture from penetrating the wood.

1.4. Anchoring the outdoor sauna

The outdoor sauna must be firmly anchored on the base plate or the strip foundation. Strong winds can exert a powerful force on the garden sauna. To prevent damage to your, or third party, property proper anchoring is essential.

We point out that anchoring the garden sauna is the responsibility of the customer and we do not accept any liability for accidental damage.

1.5. Disposal



- Dispose of packaging materials in accordance with the applicable waste disposal regulations.

1.6. Tools required

- Hammer with a wooden head or a mallet
- Cordless screwdriver with bits for cross-head screws and Torx
- Roller tape measure
- Drill bits with a diameter of 3 mm, 10 mm, 20 - 30 mm (for sauna heater power cable)
- Spirit level
- 1.5 mm hexagonal socket wrench
- Utility knife
- Ladder



This symbol indicates tips and useful information



Pre-drill



Cut to real measurement with backsaw



Check the right angle:

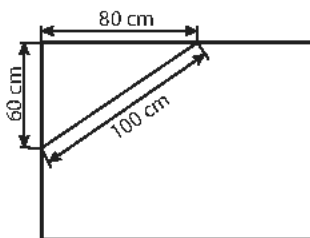

Handle glass with care: Special care must be taken with the edges of the glass – hardened glass can shatter into small pieces in the event of impact. Insert protective cushioning (e.g. cardboard box) under the edge of the glass.

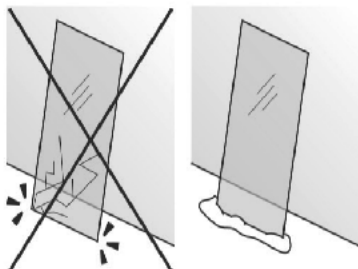

1.7. Parts list

No. of items	Name	Dimensions mm
Base frame		
2	Base frame (impregnated)	2080x40x146
2	Base frame (impregnated)	1990x40x146
1	Base frame (impregnated), middle wall	1910x40x146
2	Base frame (impregnated)	1910x40x146
W1: Front side with window and door		
1	Block plank with holes for air supply	2160x146x40
9	Block plank	2160x146x40
14	Block plank	1040x146x40
3	Block plank	118x146x40
3	Block plank	287x146x40
2	Block plank	1990x146x40
2	Block plank	2080x146x40
1	Block plank below the window	2160x146x40
1	Block plank above the window	1990x146x40
1	Block plank above the door	2080x146x40
1	Block plank with holes for ventilation	1990x131x40
1	Block plank with holes for ventilation	2080x131x40
W2: Side wall		
15	Block plank	1910x146x40
1	Block plank upper triangle	1910x397x40
W3: Rear wall		
1	Block plank with holes for exhaust air	1990x146x40
14	Block plank	1990x146x40
15	Block plank	2080x146x40
1	Block plank with holes for ventilation	1990x131x40
1	Block plank with holes for ventilation	2080x131x40
W4: Side wall		
15	Block plank	1910x146x40
1	Block plank upper triangle	1910x397x40
W5: Medium wall		
14	Block plank	110x146x40
13	Block plank with hole for cable	980x146x40
1	Block plank with hole for cable	980x146x40
1	Block plank above the door	1910x146x40
1	Block plank upper triangle	1910x397x40

No. of items	Name	Dimensions mm
Floor		
7	Base frame (impregnated)	1905x100x40
7	Base frame (impregnated)	1995x100x40
6	Base frame (impregnated)	272x100x40
41	Floor boards	1900x95x19
1	Floor boards with cutout	1900x60x19
1	Floor boards with cutout	1900x60x19
4	Skirting board	1910x25x20
1	Skirting board	2000x25x20
1	Skirting board	950x25x20
1	Skirting board	965x25x20
1	Skirting board	970x25x20
1	Skirting board	95x25x20
1	Skirting board	140x25x20
1	Skirting board	80x25x20
2	Skirting board	780x25x20
Corner covers		
10	Corner cover	1000x80x20
2	Corner cover	1630x80x20
2	Corner cover 82°	1630x80x20
1	Corner cover with cutout	1630x80x20
2	Corner cover	1360x80x20
2	Corner cover 82°	1360x80x20
1	Corner cover with cutout	1360x80x20
Inner roof		
1	Roof panel	1890x955x55
1	Roof panel	1890x955x55
1	Roof panel	1980x955x55
1	Roof panel	1980x955x55
1	Roof support strip 82°	1910x40x40
1	Roof support strip 82°	2000x40x40
1	Roof support slat	1910x40x40
1	Roof support slat	2000x40x40
2	Roof support strip 2x82° left	1847x40x40
2	Roof support strip 2x82° right	1847x40x40

No. of items	Name	Dimensions mm
Outer roof		
7	Roof rafters 82°	1719x130x40
7	Roof rafters 82°	1719x130x40
2	Wind batten support strips 82° top	2000x40x40
2	Wind batten support strips 82° bottom	1126x40x40
66	Roof tongue and groove planks	2275x95x19
2	Wind battens 82° sideways bottom	1571x150x20
2	Wind battens 82° sideways top	1571x150x20
4	Wind battens	2295x150x20
1	Roof support left	2550x70x70
1	Roof support right	2550x70x70
Outer door		
1	Outer door incl. door frame	1955x890x70
2	Door panel inside	1950x55x20
1	Door panel inside	780x55x20
Inner door		
1	Glass incl. frame	1900x820x50
2	Door panel inside	2020x55x20
1	Door panels inside	750x55x20
Window		
1	Insulating safety glass	1587x506x16
2	Window frame	1805x560x32
Interior fittings		
1	Bench	1900x600x88
1	Bench	1900x500x88
1	Bench	1305x600x88
2	Backrests	1800x220x48
2	Bench support slats	955x88x28
3	Bench support slats	595x88x28
2	Heater protection grille	1000x88x28
1	Heater protection grille	490x70x28
1	Heater protection grille	675x70x28
1	Heater protection guard (strut)	575x88x28

No. of items	Name	Dimensions mm
Terrace		
6	Base frame (impregnated)	2090x95x40
32	Terrace floorboards	825x120x25
2	Cover strip	825x95x25
2	Screen element	1970x780x60
2	Roof supports	2550x70x70
Accessories		
2	Ventilation slide 620P	215x170x20
2	Ventilation grille	250x250x30
2	Headrest 520S	430x250x70
1	Lamp protective grille 920S	
1	Lamp without bulb	
2	Polymer adhesive (290 ml)	
12	Stainless steel ventilation grille	
2	Metal angle	60x60x3
146	Iron pins	120x12x2
2	Roofing felt	
1	Assembly material set	
1	Assembly instructions	

2. Floor plan/foundation

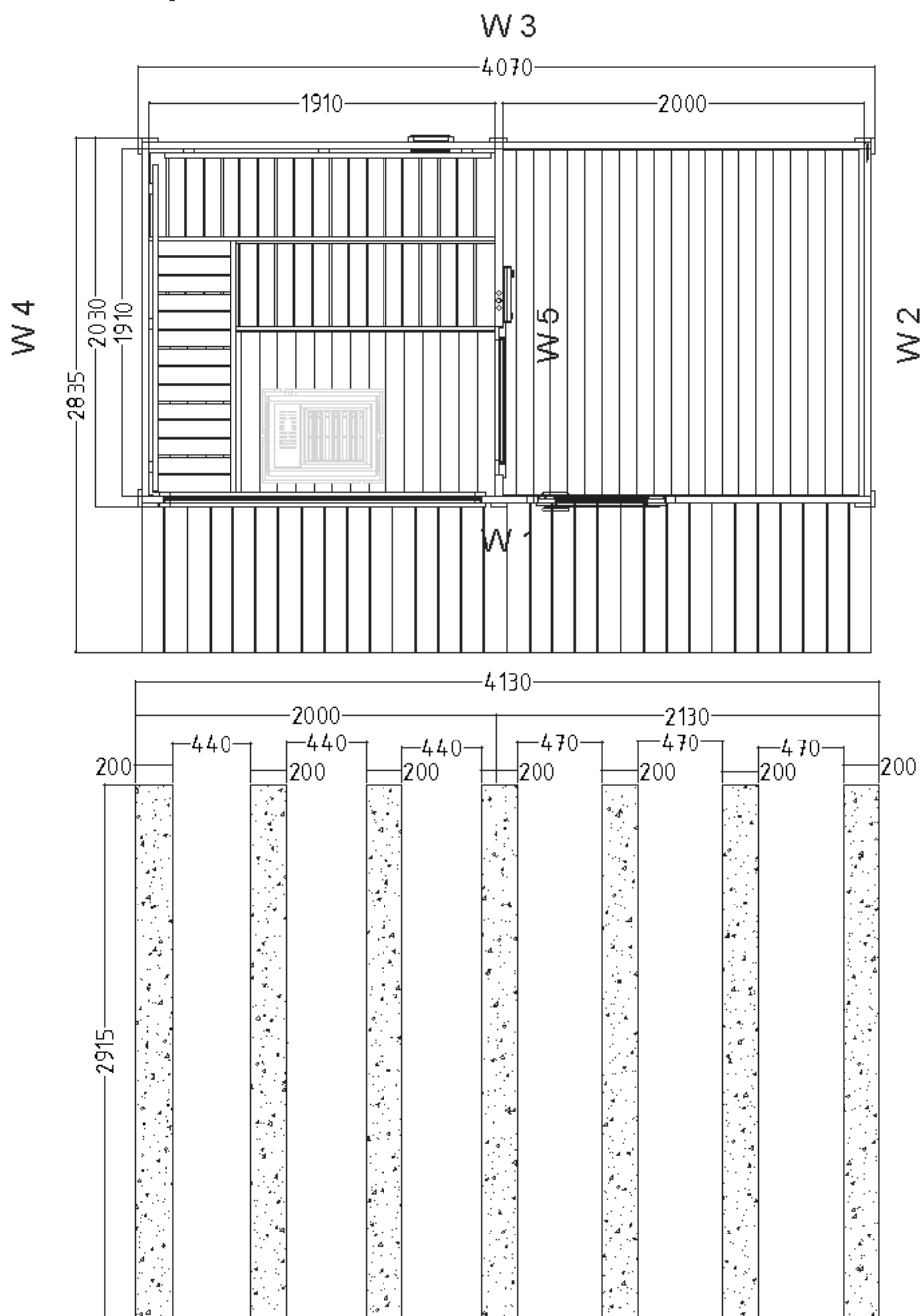

3. View/dimensions

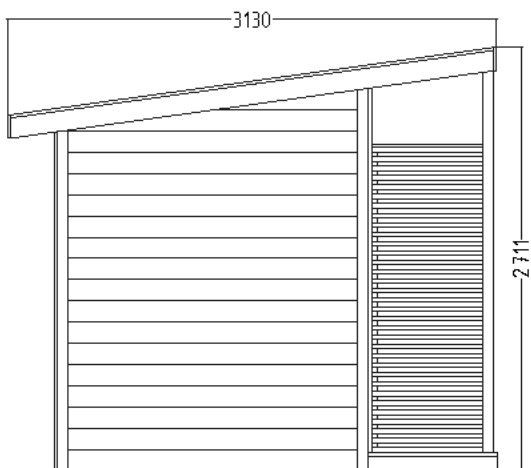
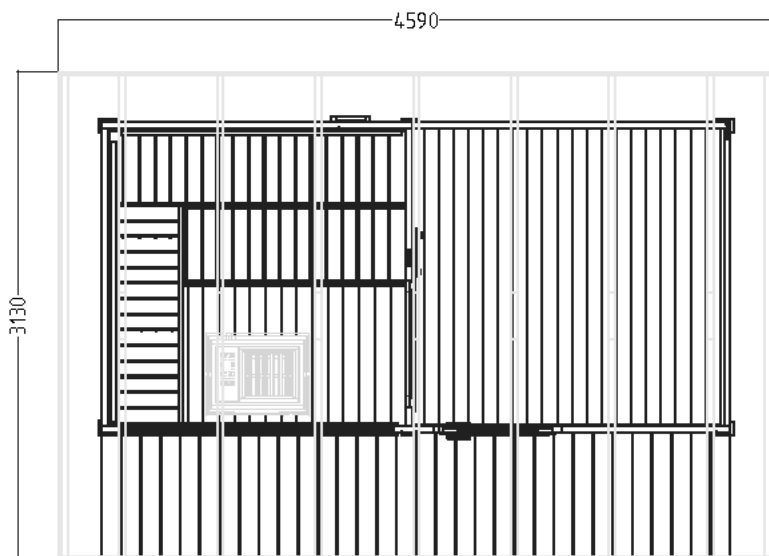

4. Assembling the cabin



ATTENTION!

Note the floor plans on page 11 and illustrations from page 15 onwards.

4.1. Assembling the base frame

Place the impregnated base frame on the foundation as shown on the floor plan and the foundation illustrations (see pages 11 and 12). Glue the floor frame at the corners and screw the parts together with 5 x 90 mm screws.

4.2. Installing the floor substructure

Place the impregnated floor frame in the cabin and screw it to the base frame.



Note the placement of the cable and the positioning of the short floor timbers (272 x 100 x 40) for reinforcing the surfaces where the heater stands.

4.3. Assembling the cabin walls

Start by fitting the block planks on the rear wall. Proceed row by row. As with the base frame, glue and screw the corners together. Hammer the iron pins into the pre-drilled holes in each row.



Check that the block planks are at right angles before screwing the corners together (see page 4).
Note the position of the ventilation slide in the second row.

4.4. Installing the floor

Fit the floor boards.

4.5. Installing the interior roof

Install the roof support slats. Distance to the top edge: 210 mm.
Installing the interior lighting.
Put the roof elements in place.

4.6. Installing the benches and backrests

4.7. Installing the windows and doors

First insert the window frame on the inside and screw it to the cabin wall. Insert the glass from the outside and fit the second window frame.

Place the inner door from the lobby into the door opening and fix it by fitting the door panel inside from the sauna interior.

Place the outer door in the door opening and fix it by fitting the door panel from the inside.

4.8. Fit the skirting boards

4.9. Ventilation slit installation

4.10. Installing the outer roof

Glue and screw the roof rafters and place them in the recesses according to the illustration. Screw the roof rafters to the block planks. Attach the tongue and groove planks to the roof rafters.

Attach the battens 82° - 40x40 to the side of the tongue and groove planks and the wind battens 82° 1571x150x40 on the top.

Attach the wind battens 2295x150x20 to the front and back.

The roofing felt included in the scope of delivery serves as an initial roofing. We also recommend covering the roof with bitumen shingles, sheet metal or a suitable foil.

4.11. Installing the terrace

Place the floor frame of the terrace as shown in the photos (see page 32) and screw it to the base frame of the cabin. Then mount the cover boards (825x95x25) to the base frame.

Fit the floor boards.

4.12. Installing the corner strips and ventilation grille

4.13. Installing the screen elements and roof supports

Gartensauna

SCALA Large

459 x 313 x 272 cm

MONTAGEANLEITUNG
Deutsch

DE



Table of Contents

1. Montage Vorbereitung	3
1.1. Wichtige Hinweise	3
1.2. Wartung und Reinigung	4
1.3. Fundament	4
1.4. Verankerung der Außensauna	5
1.5. Entsorgung	5
1.6. Benötigtes Werkzeug	6
1.7. Stückliste	7
2. Grundrissplan / Fundament	11
3. Ansicht / Abmessungen	12
4. Montage Kabine	13
4.1. Montage Grundrahmen	13
4.2. Montage Boden Unterkonstruktion	13
4.3. Montage Kabinenwände	13
4.4. Montage Boden	13
4.5. Montage Innendach	13
4.6. Montage Bänke und Rückenlehne	13
4.7. Montage Fenster und Türen	14
4.8. Montage der Sockelleisten	14
4.9. Montage Lüftungsschieber	14
4.10. Montage Außendach	14
4.11. Montage der Terrasse	14
4.12. Montage der Eckleisten und Lüftungsgitter	14
4.13. Montage der Sichtschutz-Elemente und Dachstützen	14
Montage Abbildungen (nach der letzten Sprache)	15

1. Montage Vorbereitung

Lesen Sie diese Montageanleitung gut durch und bewahren Sie sie auf. So können Sie jederzeit Produktinformationen nachlesen.



Sie finden diese Montageanleitung auch im Downloadbereich unserer Webseite auf www.sentiotec.com/downloads.

1.1. Wichtige Hinweise

- Erkundigen Sie sich bei Ihrer zuständige Baubehörde (Gemeindeamt, Magistrat) bezüglich den Bauvorschriften und Belastungsnormen.
- Ein solides Betonfundament ist wichtig für die Haltbarkeit sowie für die Sicherheit Ihrer Außensauna. Wir empfehlen Ihnen das Fundament von einem Fachmann herstellen zu lassen.
- Die Verankerung der Außensauna liegt im Verantwortungsbereich des Kunden. Keine Gewährleistung bei auftretenden Schäden.
- Die Außensauna wird per LKW (eventuell auch per Sattelzug) angeliefert. Dabei muss gewährleistet sein, dass die Zufahrt zum Entladeort möglich ist.
- Kontrollieren Sie, bevor Sie mit der Arbeit beginnen, anhand der Stückliste, ob alle Einzelteile auch tatsächlich mitgeliefert wurden. Sollten Einzelteile ausnahmsweise fehlen, benachrichtigen Sie spätestens 14 Tage nach Erhalt der Kabine Ihren Händler.
- Bewahren Sie den Lieferschein, die Rechnung und die Montageanleitung für eventuelle Rückfragen gut auf.
- Für die Montage benötigen Sie einen Helfer.
- Alle Verschraubungen müssen vorgebohrt werden.

DE



Achtung!

Der Elektroanschluss darf nur durch eine Elektrofachkraft oder eine vergleichsweise qualifizierte Person ausgeführt werden.

- Die im Lieferumfang enthaltene Dachpappe dient als Ersteindeckung. Wir empfehlen zusätzlich das Dach mit Bitumenschindeln, Blech oder einer geeigneten Folie einzudecken.
- Holz ist ein Naturprodukt, das trotz guter Lagerung aufquellen, schwinden oder sich verziehen kann. Aus diesem Grund kann es vorkommen, dass bei der Montage etwas Kraft aufgebracht werden muss.

- Das Holz der Außensauna ist unbehandelt. Um die Lebensdauer zu erhöhen, empfehlen wir, außen mit einer geeigneten Holzschutzfarbe zu streichen.
- Die Innen zu verwendenden Holzteile dürfen nicht mit Farbe behandelt werden.

1.2. Wartung und Reinigung

- Die Sauna sollte innen mit einem feuchten Tuch gereinigt werden. Verwenden Sie nur warmes Wasser - keine Reinigungsmittel.
- Wird die Sauna längere Zeit nicht benutzt, empfehlen wir, die Kabine einmal im Monat aufzuheizen.



Harzgallen sind kein Reklamationsgrund. Da in Fichtenholz immer wieder Harzgallen vorkommen und man beim Aussortieren nicht erkennen kann in welcher Tiefe diese sich befinden.

Wenn diese knapp unter der Oberfläche sind brechen sie bei Hitzeentwicklung auf und „bluten“ aus.

Das ausgelaufene Harz kann man mit einem Aceton gedrängtem Lappen entfernen. Wenn lediglich Harztropfen entstehen, lassen Sie diese aushärten und schaben sie anschließend mit einem Messer vorsichtig ab.

1.3. Fundament

Diese folgenden Fundmente haben sich in der Praxis bewährt:

- Fundamentplatte (Bodenplatte)
- Streifenfundament

Dabei ist bei beiden Varianten ein absolut waagrechtes und tragfähiges Fundament zu gewährleisten. Nur so kann eine einwandfreie Montage der Außensauna mit einer exakten Passgenauigkeit gewährleistet werden.

Wir empfehlen, Teerband zwischen dem Sockelholz und dem Beton zu verwenden, um zu verhindern, dass Feuchtigkeit in das Holz eindringt.

1.4. Verankerung der Außensauna

Es ist sehr wichtig, dass die Außensauna fest mit der Bodenplatte oder dem Streifenfundament verankert wird. Bei starkem Wind können große Kräfte auf das Gartenhaus einwirken. Um Schäden am eigenen oder fremden Eigentum zu vermeiden ist eine fachgerechte Verankerung unbedingt notwendig.

Wir weisen Sie darauf hin, dass die Verankerung des Gartenhauses im Verantwortungsbereich des Kunden liegt, und wir für auftretende Schäden keine Gewährleistung übernehmen.

1.5. Entsorgung



- Entsorgen Sie die Verpackungsmaterialien nach den gültigen Entsorgungsrichtlinien.

1.6. Benötigtes Werkzeug

- Hammer und Beilageholz oder einen Gummihammer
- Akkuschauber mit Bits für Kreuzschrauben und Torx
- Rollmaßband
- Bohrer mit Durchmesser 3 mm, 10 mm, 20 - 30 mm (für Stromkabel Saunaofen)
- Wasserwaage
- Innensechskant-Schlüssel 1,5 mm
- Universalmesser
- Leiter



Dieses Symbol kennzeichnet Tipps und nützliche Hinweise



Vorbohren



Ablängen auf Naturmaß mit Feinsäge



Überprüfung des rechten Winkel:

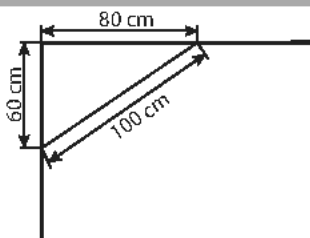

Vorsichtiger Umgang mit Glas: Besondere Vorsicht gilt den Glaskanten - Gehärtetes Glas kann bei Stößen in kleine Scherben zerspringen. Legen Sie ein Schutzpolster (z. Bsp.: Verpackungs-Karton) unter die Glaskante.

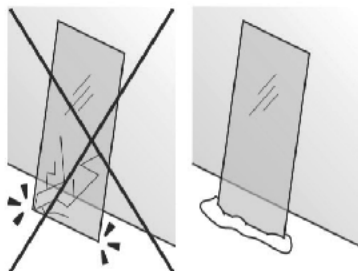

1.7. Stückliste

No. of items	Name	Dimensions mm
Grundrahmen		
2	Grundrahmen (imprägniert)	2080x146x40
2	Grundrahmen (imprägniert)	1990x146x40
1	Grundrahmen (imprägniert) Mittelwand	1910x146x40
2	Grundrahmen (imprägniert)	1910x146x40
W1: Vorderseite mit Fenster und Tür		
1	Blockbohle mit Bohrungen für Zuluft	2160x146x40
9	Blockbohle	2160x146x40
14	Blockbohle	1040x146x40
3	Blockbohle	118x146x40
3	Blockbohle	287x146x40
2	Blockbohle	1990x146x40
2	Blockbohle	2080x146x40
1	Blockbohle unten der Fenster	2160x146x40
1	Blockbohle über der Fenster	1990x146x40
1	Blockbohle über der Tür	2080x146x40
1	Blockbohle mit Bohrungen für Belüftung	1990x131x40
1	Blockbohle mit Bohrungen für Belüftung	2080x131x40
W2: Seitenwand		
15	Blockbohle	1910x146x40
1	Blockbohle oberes Dreieck	1910x397x40
W3: Rückwand		
1	Blockbohle mit Bohrungen für Abluft	1990x146x40
14	Blockbohle	1990x146x40
15	Blockbohle	2080x146x40
1	Blockbohle mit Bohrungen für Belüftung	1990x131x40
1	Blockbohle mit Bohrungen für Belüftung	2080x131x40
W4: Seitenwand		
15	Blockbohle	1910x146x40
1	Blockbohle oberes Dreieck	1910x397x40
W5: Mittelwand		
14	Blockbohle	110x146x40
13	Blockbohle mit Bohrung für Kabel	980x146x40
1	Blockbohle mit Bohrung für Kabel	980x146x40
1	Blockbohle über der Tür	1910x146x40
1	Blockbohle oberes Dreieck	1910x397x40

No. of items	Name	Dimensions mm
Boden		
7	Bodenrahmen (imprägniert)	1905x100x40
7	Bodenrahmen (imprägniert)	1995x100x40
6	Bodenrahmen (imprägniert)	272x100x40
41	Bodenbretter	1900x95x19
1	Bodenbretter mit Ausschnitt	1900x60x19
1	Bodenbretter mit Ausschnitt	1900x60x19
4	Sockelleiste	1910x25x20
1	Sockelleiste	2000x25x20
1	Sockelleiste	950x25x20
1	Sockelleiste	965x25x20
1	Sockelleiste	970x25x20
1	Sockelleiste	95x25x20
1	Sockelleiste	140x25x20
1	Sockelleiste	80x25x20
2	Sockelleiste	780x25x20
Eckabdeckungen		
10	Eckabdeckung	1000x80x20
2	Eckabdeckung	1630x80x20
2	Eckabdeckung 82°	1630x80x20
1	Eckabdeckung mit Ausschnitt	1630x80x20
2	Eckabdeckung	1360x80x20
2	Eckabdeckung 82°	1360x80x20
1	Eckabdeckung mit Ausschnitt	1360x80x20
Dach innen		
1	Dachpanel Sauna	1890x955x55
1	Dachpanel Sauna	1890x955x55
1	Dachpanel Vorraum	1980x955x55
1	Dachpanel Vorraum	1980x955x55
1	Dachauflageleiste 82°	1910x40x40
1	Dachauflageleiste 82°	2000x40x40
1	Dachauflageleiste	1910x40x40
1	Dachauflageleiste	2000x40x40
2	Dachauflageleiste 2x82° links	1847x40x40
2	Dachauflageleiste 2x82° rechts	1847x40x40

No. of items	Name	Dimensions mm
Dach außen		
7	Dachsparren 82°	1719x130x40
7	Dachsparren 82°	1719x130x40
2	Windlatten Unterstützungsleisten 82° oben	2000x40x40
2	Windlatten Unterstützungsleisten 82° unten	1126x40x40
66	Dach Nut- und Federbretter	2275x95x19
2	Windlatten 82° seitlich unten	1571x150x20
2	Windlatten 82° seitlich oben	1571x150x20
4	Windlatten	2295x150x20
1	Dachstütze links	2550x70x70
1	Dachstütze rechts	2550x70x70
Außentür		
1	Außentür inkl. Türstock	1955x890x70
2	Türverblendung innen	1950x55x20
1	Türverblendung innen	780x55x20
Innentür		
1	Glas inkl. Rahmen	1900x820x50
2	Türverblendung innen	2020x55x20
1	Türverblendungen innen	750x55x20
Window		
1	isolierendes Sicherheitsglas	1587x506x16
2	Fensterrahmen	1805x560x32
Inneneinrichtung		
1	Bank	1900x600x88
1	Bank	1900x500x88
1	Bank	1305x600x88
2	Rückenlehne	1800x220x48
2	Bankauflageleisten	955x88x28
3	Bankauflageleisten	595x88x28
2	Ofenschutzgitter	1000x88x28
1	Ofenschutzgitter	490x70x28
1	Ofenschutzgitter	675x70x28
1	Ofenschutzgitter (Strebe)	575x88x28

No. of items	Name	Dimensions mm
Terrasse		
6	Grundrahmen (imprägniert)	2090x95x40
32	Bodenbretter	825x120x25
2	Abdeckbretter	825x95x25
2	Sichtschutzelement	1970x780x60
1	Dachstütze links	2550x70x70
1	Dachstütze rechts	2550x70x70
Zubehör		
2	Lüftungsschieber 620P	215x170x20
2	Lüftungsgitter	250x250x30
2	Kopfstütze 520S	430x250x70
1	Lampenschutzgitter 920S	
1	Leuchte ohne Leuchtmittel	
2	Polymerkleber (290ml)	
12	Edelstahl Lüftungsgitter	
2	Metall Winkel	60x60x3
146	Eisenstifte	120x12x2
2	Dachpappe	
1	Montage Material Set	
1	Montageanleitung	

2. Grundrissplan / Fundament

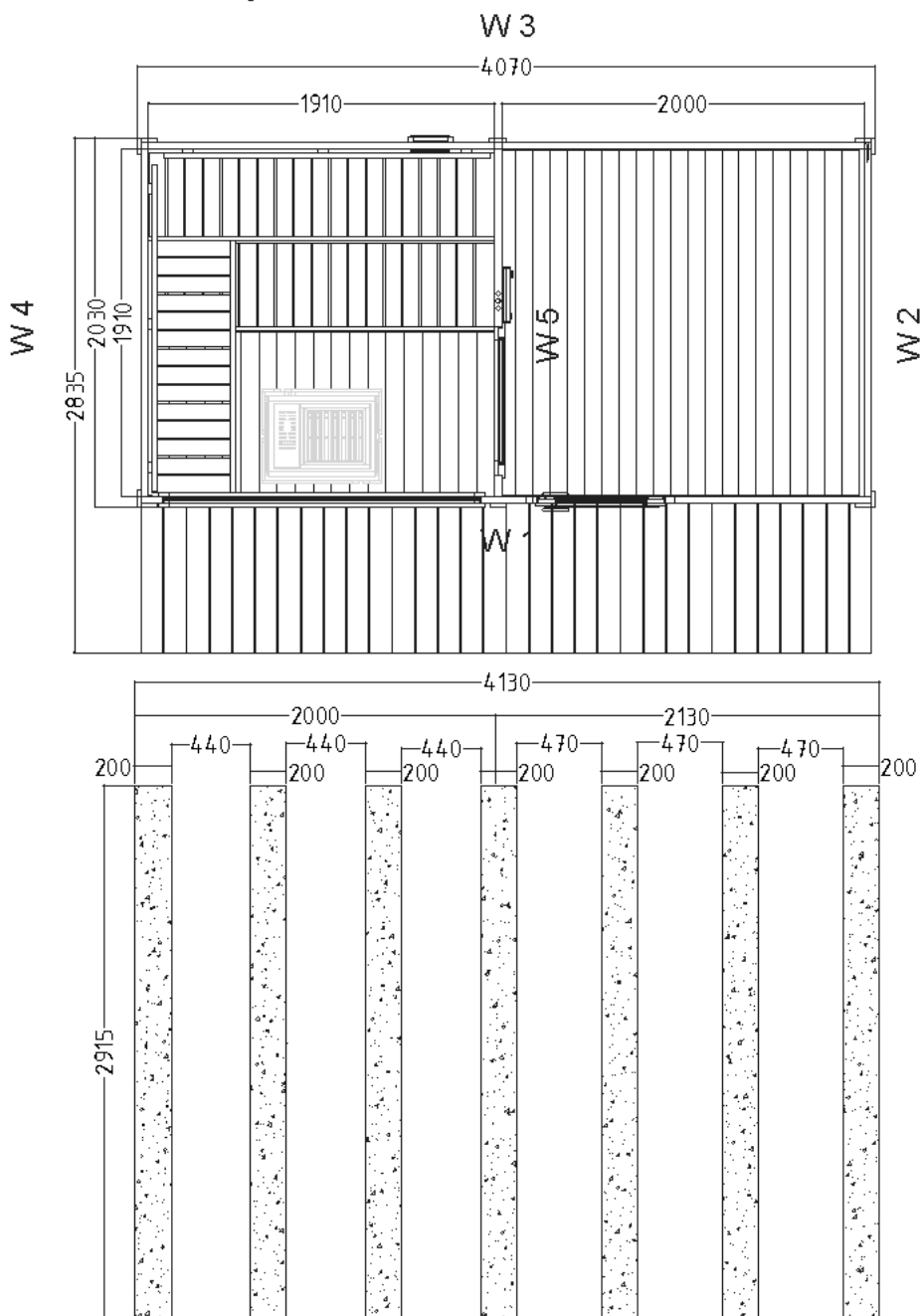

3. Ansicht / Abmessungen

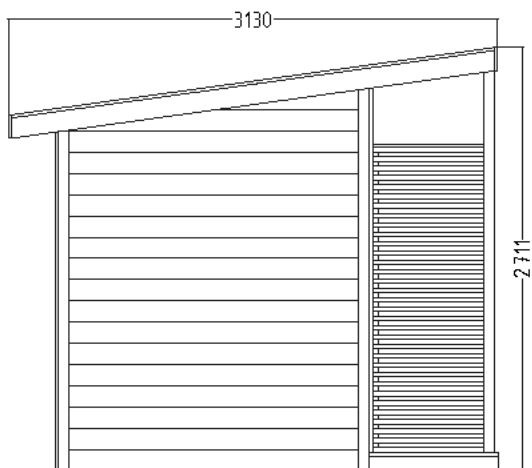
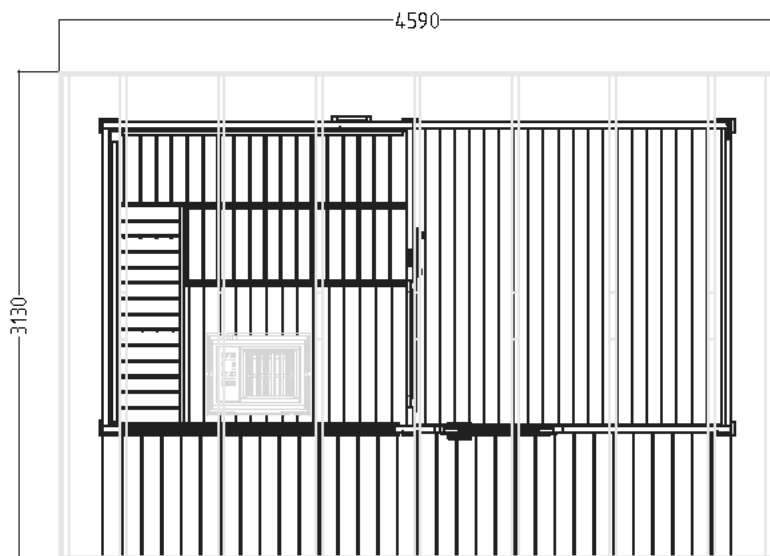

4. Montage Kabine

**ACHTUNG!**

Beachten Sie den Grundriss auf Seite 11 und die Abbildungen ab Seite 15.

4.1. Montage Grundrahmen

Legen Sie den imprägnierten Grundrahmen auf das Fundament wie dies im Grundriss und in den Fundament-Darstellungen angezeigt ist (siehe Seite 11 und 12). Verleimen Sie den Bodenrahmen an den Ecken und verschrauben Sie die Teile mit 5 x 90 mm Schrauben.

4.2. Montage Boden Unterkonstruktion

Legen Sie den imprägnierten Bodenrahmen in die Kabine und verschrauben Sie diese mit dem Grundrahmen.



Beachten Sie die Verlegung der Kabel und die Positionierung der kurzen Bodenhölzer (272 x 100 x 40) zur Versteifung der Ofenstellfläche!

DE

4.3. Montage Kabinenwände

Beginnen Sie mit der Montage der Blockbohlen an der Rückwand. Gehen Sie Reihe für Reihe vor. Wie beim Grundrahmen verleimen und verschrauben Sie die



Überprüfen Sie die rechten Winkel, bevor Sie die Blockbohlen an den Ecken verschrauben (Hinweis Seite 4).

Beachten Sie die Position der Lüftungsschieber in Reihe 2!

Ecken. Schlagen Sie bei jeder Reihe die Eisenstifte in die vorgebohrten Löcher.

4.4. Montage Boden

Montage der Bodenbretter.

4.5. Montage Innendach

Montage der Dachauflageleisten. Abstand zur Oberkante: 210 mm.

Montage der Innenbeleuchtung.

Legen Sie die Dachelemente ein.

4.6. Montage Bänke und Rückenlehne

4.7. Montage Fenster und Türen

Setzen Sie zuerst den Fensterrahmen innen ein und verschrauben ihn mit der Kabinenwand. Setzen Sie das Glas von außen ein und montieren Sie den zweiten Fensterrahmen.

Stellen Sie die Innentür vom Vorraum aus in die Türöffnung und fixieren Sie ihn durch die Montage der Türverblendung innen von der Sauna-Innenseite.

Stellen Sie die Außentür in die Türöffnung und und fixieren Sie sie durch die Montage der Türverblendung von der Innenseite.

4.8. Montage der Sockelleisten

4.9. Montage Lüftungsschieber

4.10. Montage Außendach

Verleimen und verschrauben Sie die Dachsparren und legen Sie diese laut Abbildung in die Ausnehmungen. Verschrauben Sie die Dachsparren mit den Blockbohlen. Befestigen Sie die Nut-Federbretter an den Dachsparren.

Befestigen Sie die Leisten 82°- 40x40 seitlich an den Nut-Federbrettern und darauf die Windlatten 82°- 1571x150x40.

Befestigen Sie die Windlatten 2295x150x20 vorne und hinten.

Die im Lieferumfang enthaltene Dachpappe dient als Ersteindeckung. Wir empfehlen zusätzlich das Dach mit Bitumenschindeln, Blech oder einer geeigneten Folie einzudecken.

4.11. Montage der Terrasse

Legen Sie den Grundrahmen der Terrasse wie auf den Fotos (siehe Seite 32) ersichtlich und verschrauben diese mit dem Grundrahmen der Kabine. Dann montieren Sie die Abdeckbretter (825x95x25) am Grundrahmen.

Montage der Bodenbretter.

4.12. Montage der Eckleisten und Lüftungsgitter

4.13. Montage der Sichtschutz-Elemente und Dachstützen

Sauna de jardin

SCALA Large

459 x 313 x 272 cm

INSTRUCTIONS DE MONTAGE

Français



FR

Table des matières

1. Préparation du montage	3
1.1. Remarques importantes	3
1.2. Entretien et nettoyage	4
1.3. Fondation	4
1.4. Ancrage du sauna extérieur	5
1.5. Élimination	5
1.6. Outils requis	6
1.7. Nomenclature	7
2. Plan de construction / fondation	11
3. Vue / dimensions	12
4. Montage de la cabine	13
4.1. Montage du cadre de base	13
4.2. Montage de la structure porteuse du plancher	13
4.3. Montage des parois de la cabine	13
4.4. Montage du plancher	13
4.5. Montage de l'intérieur du toit	13
4.6. Montage des bancs et des dossiers	13
4.7. Montage des fenêtres et des portes	14
4.8. Montage des plinthes	14
4.9. Montage du registre d'aération	14
4.10. Montage de l'extérieur du toit	14
4.11. Montage de la terrasse	14
4.12. Montage des barres d'angle et des grilles d'aération	14
4.13. Montage de l'écran de protection et des supports de toit	14
Illustrations de montage (en fonction de la dernière langue)	15

1. Préparation du montage

Lisez attentivement ces instructions de montage et conservez-les. Vous avez ainsi accès à tout moment aux informations sur le produit.



Vous pouvez également trouver ces instructions de montage dans la zone de téléchargement de notre site Web : www.sentiotec.com/downloads.

1.1. Remarques importantes

- Renseignez-vous auprès de l'autorité locale chargée de la construction (bureau municipal, magistrat) sur les règles de construction et les normes relatives aux charges.
- Pour la durabilité et la sécurité de votre sauna extérieur, il est important que la fondation en béton soit solide. Nous vous recommandons de faire construire les fondations par un spécialiste.
- La responsabilité de l'ancrage du sauna extérieur incombe au client. Aucune garantie n'est accordée en cas de dommage.
- Le sauna extérieur est livré par camion (éventuellement par semi-remorque). Il faut donc veiller à ce que l'accès au site de déchargement soit possible.
- Avant de commencer les travaux, vérifiez au moyen de la nomenclature si toutes les pièces ont bien été livrées. S'il devait s'avérer que des pièces manquent, informez votre revendeur dans les 14 jours suivant la réception de la cabine.
- Conservez le bon de livraison, la facture et les instructions de montage en lieu sûr pour toute question éventuelle.
- Une deuxième personne doit être disponible pour vous aider.
- Tous les raccords vissés doivent être préalésés.

FR



Attention !

Seul un électricien spécialisé ou une personne ayant une qualification similaire est habilité à procéder au raccordement électrique.

- Le feutre de toiture inclus dans la livraison sert de toiture initiale. Nous recommandons de recouvrir en outre la toiture de bardeaux de bitume, de tôle ou d'un film approprié.
- Malgré un stockage correct, le bois est un produit naturel qui peut gonfler, se contracter ou se déformer. C'est pourquoi il peut arriver que vous ayez à appliquer de la force lors du montage.

- Le bois du sauna extérieur n'est pas traité. Pour augmenter sa durée de vie, nous recommandons de peindre l'extérieur avec une peinture de protection du bois adaptée.
- Les pièces en bois utilisées à l'intérieur du sauna ne doivent pas être traitées avec de la peinture.

1.2. Entretien et nettoyage

- L'intérieur du sauna doit être nettoyé à l'aide d'un chiffon humide. N'utilisez que de l'eau chaude, pas de détergent.
- Si le sauna n'est pas utilisé pendant une période prolongée, nous recommandons de chauffer la cabine une fois par mois.



Les poches de résine ne constituent pas un motif de réclamation, en raison de leur présence régulière dans le bois d'épicéa et de l'impossibilité de déterminer leur profondeur lors de la sélection du bois.

Si elles se trouvent juste sous la surface, elles éclatent et s'écoulent quand elle sont exposées à la chaleur.

Retirez la résine écoulée à l'aide d'un chiffon imbibé d'acétone. Si vous constatez uniquement des gouttes de résine, attendez qu'elles aient durci, puis grattez-les avec précaution à l'aide d'un couteau.

1.3. Fondation

Les fondations suivantes ont fait leurs preuves dans la pratique :

- Plaque de fondation (dalle)
- Semelles filantes

Dans les deux variantes, une fondation absolument horizontale et porteuse doit être garantie. Ce n'est que de cette manière qu'un montage parfait du sauna extérieur peut être garanti avec un ajustement exact.

Nous recommandons d'utiliser du ruban goudronné entre le bois situé à la base et le béton pour empêcher l'humidité de pénétrer dans le bois.

1.4. Ancrage du sauna extérieur

Il est très important que le sauna extérieur soit solidement ancré à la dalle ou aux semelles filantes. Par vent fort, de grandes forces peuvent agir sur la maisonnette de jardin. Afin d'éviter d'endommager votre propriété ou les biens de tiers, un ancrage professionnel est absolument nécessaire.

Nous attirons votre attention sur le fait que l'ancrage de la maisonnette de jardin est à la charge du client et que nous déclinons toute responsabilité pour les dommages qui pourraient survenir.

1.5. Élimination



- Éliminez les matériaux d'emballage conformément aux directives en vigueur relatives à l'élimination.

1.6. Outils requis

- Marteau et cales ou maillet en caoutchouc
- Visseuse électrique avec bits pour vis en croix et Torx
- Ruban de mesure
- Foret de 3 mm de diamètre, 10 mm, 20 - 30 mm (pour câble électrique poêle de sauna)
- Niveau à bulle
- Clé Allen 1,5 mm
- Couteau universel
- Échelle



Ce symbole désigne les conseils et indications utiles.



Préalésage



Sciage à la bonne longueur avec une scie fine



Contrôle de l'angle droit :

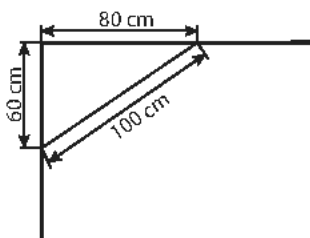

Manipulez le verre avec soin : Faire particulièrement attention avec les bords de la vitre ; en cas de choc, le verre trempé peut se briser en petits morceaux. Placez un rembourrage de protection (par ex., un emballage en carton) sous le bord de la vitre.

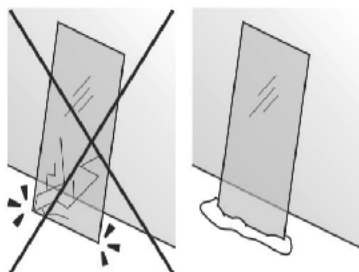

1.7. Nomenclature

Qté	Nom	Dimensions mm
Cadre de base		
2	Cadre de base (imprégné)	2080x40x146
2	Cadre de base (imprégné)	1990x40x146
1	Cadre de base (imprégné) – Paroi intermédiaire	1910x40x146
2	Cadre de base (imprégné)	1910x40x146
W1 : Côté avant avec fenêtre et porte		
1	Madrier avec trous percés pour l'arrivée d'air	2160x146x40
9	Madrier	2160x146x40
14	Madrier	1040x146x40
3	Madrier	118x146x40
3	Madrier	287x146x40
2	Madrier	1990x146x40
2	Madrier	2080x146x40
1	Madrier (sous la fenêtre)	2160x146x40
1	Madrier (au-dessus de la fenêtre)	1990x146x40
1	Madrier (au-dessus de la porte)	2080x146x40
1	Madrier avec trous percés pour l'aération	1990x131x40
1	Madrier avec trous percés pour l'aération	2080x131x40
W2 : Paroi latérale		
15	Madrier	1910x146x40
1	Madrier (au-dessus du triangle)	1910x397x40
W3 : Paroi arrière		
1	Madrier avec trous percés pour l'air évacué	1990x146x40
14	Madrier	1990x146x40
15	Madrier	2080x146x40
1	Madrier avec trous percés pour l'aération	1990x131x40
1	Madrier avec trous percés pour l'aération	2080x131x40
W4 : Paroi latérale		
15	Madrier	1910x146x40
1	Madrier (au-dessus du triangle)	1910x397x40
W5 : Paroi intermédiaire		
14	Madrier	110x146x40
13	Madrier avec trou percé pour les câbles	980x146x40
1	Madrier avec trou percé pour les câbles	980x146x40
1	Madrier (au-dessus de la porte)	1910x146x40
1	Madrier (au-dessus du triangle)	1910x397x40

Qté	Nom	Dimensions mm
Plancher		
7	Cadre de plancher (imprégné)	1905x100x40
7	Cadre de plancher (imprégné)	1995x100x40
6	Cadre de plancher (imprégné)	272x100x40
41	Plancher	1900x95x19
1	Plancher avec découpe	1900x60x19
1	Plancher avec découpe	1900x60x19
4	Plinthe	1910x25x20
1	Plinthe	2000x25x20
1	Plinthe	950x25x20
1	Plinthe	965x25x20
1	Plinthe	970x25x20
1	Plinthe	95x25x20
1	Plinthe	140x25x20
1	Plinthe	80x25x20
2	Plinthe	780x25x20
Cache angle		
10	Cache angle	1000x80x20
2	Cache angle	1630x80x20
2	Cache angle (82°)	1630x80x20
1	Cache angle avec découpe	1630x80x20
2	Cache angle	1360x80x20
2	Cache angle (82°)	1360x80x20
1	Cache angle avec découpe	1360x80x20
Partie intérieure du toit		
1	Panneau de toit	1890x955x55
1	Panneau de toit	1890x955x55
1	Panneau de toit	1980x955x55
1	Panneau de toit	1980x955x55
1	Baguette d'appui de toiture (82°)	1910x40x40
1	Baguette d'appui de toiture (82°)	2000x40x40
1	Baguette d'appui de toiture	1910x40x40
1	Baguette d'appui de toiture	2000x40x40
2	Baguette d'appui de toiture, 2x82°, gauche	1847x40x40
2	Baguette d'appui de toiture, 2x82°, droite	1847x40x40

Qté	Nom	Dimensions mm
Partie extérieure du toit		
7	Chevron de toit 82°	1719x130x40
7	Chevron de toit 82°	1719x130x40
2	Baguettes de support supérieures pour lattes d'angle, 82°	2000x40x40
2	Baguettes de support inférieures pour lattes d'angle, 82°	1126x40x40
66	Planches à languettes et à rainures pour le toit	2275x95x19
2	Lattes d'angle, 82° latérales inférieures	1571x150x20
2	Lattes d'angle, 82° latérales supérieures	1571x150x20
4	Lattes d'angle	2295x150x20
1	Support de toit gauche	2550x70x70
1	Support de toit droit	2550x70x70
Porte extérieure		
1	Porte extérieure (cadre de porte inclus)	1955x890x70
2	Garniture de porte intérieure	1950x55x20
1	Garniture de porte intérieure	780x55x20
Porte intérieure		
1	Verre avec cadre	1900x820x50
2	Garniture de porte intérieure	2020x55x20
1	Garnitures de porte intérieures	750x55x20
Fenêtre		
1	Verre de sécurité isolant	1587x506x16
2	Cadre de fenêtre	1805x560x32
Équipement intérieur		
1	Banc	1900x600x88
1	Banc	1900x500x88
1	Banc	1305x600x88
2	Dossier	1800x220x48
2	Baguettes d'appui de banc	955x88x28
3	Baguettes d'appui de banc	595x88x28
2	Grilles de protection de poêle	1000x88x28
1	Grilles de protection de poêle	490x70x28
1	Grilles de protection de poêle	675x70x28
1	Grille de protection de poêle (étau)	575x88x28

Qté	Nom	Dimensions mm
Terrasse		
6	Cadre de base (imprégné)	2090x95x40
32	Planches de terrasse	825x120x25
2	Champlat	825x95x25
2	Écran de protection	1970x780x60
2	Supports de toit	2550x70x70
Accessoires		
2	Registres d'aération 620P	215x170x20
2	Grilles d'aération	250x250x30
2	Appui-tête 520S	430x250x70
1	Grille de protection pour lampe 920S	
1	Lampe sans ampoule	
2	Adhésif polymère (290 ml)	
12	Grille d'aération en acier inoxydable	
2	Équerre d'angle en métal	60x60x3
146	Goupilles en fer	120x12x2
2	Feutre de toiture	
1	Kit de matériel d'assemblage	
1	Instructions de montage	

2. Plan de construction / fondation

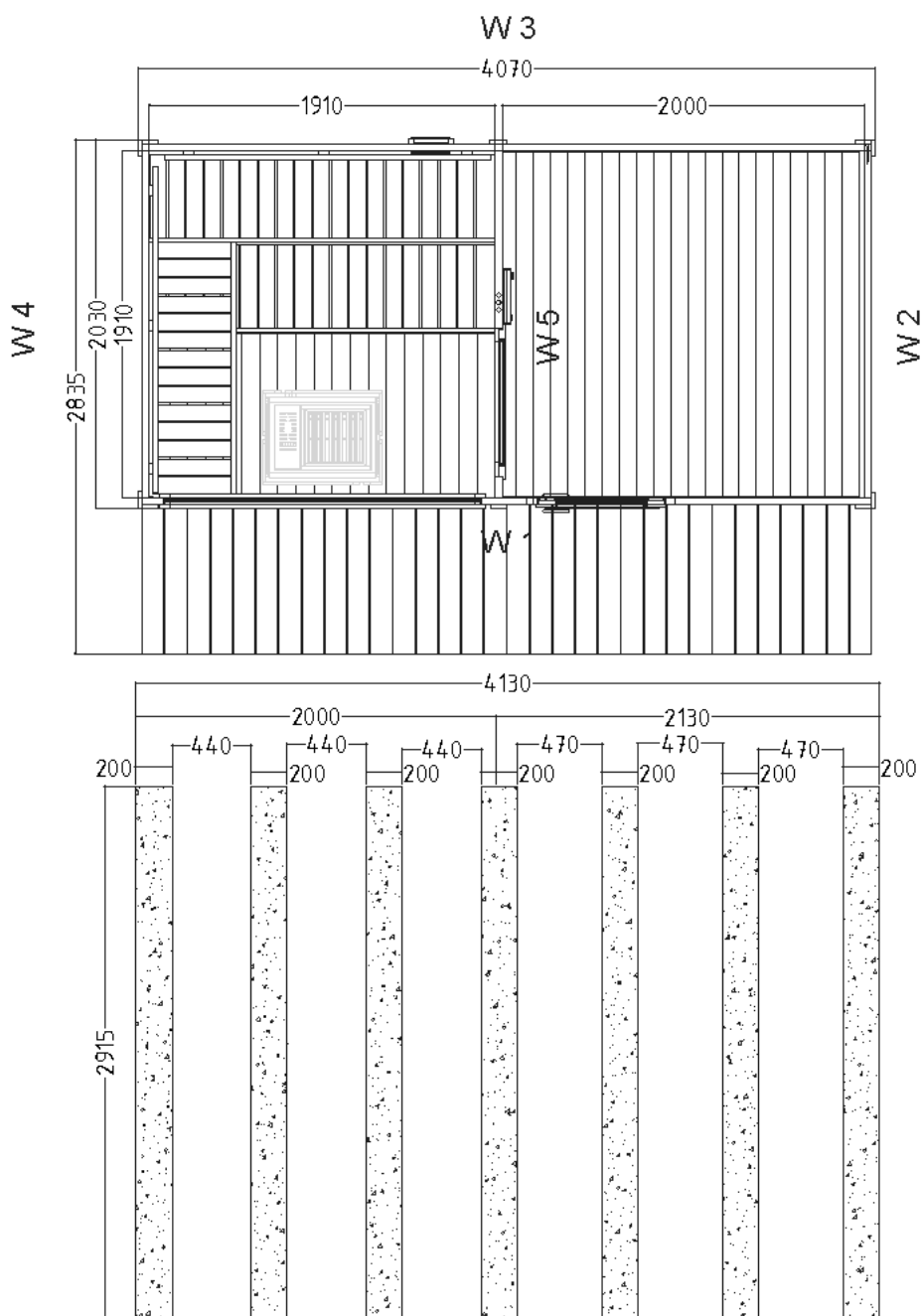

3. Vue / dimensions

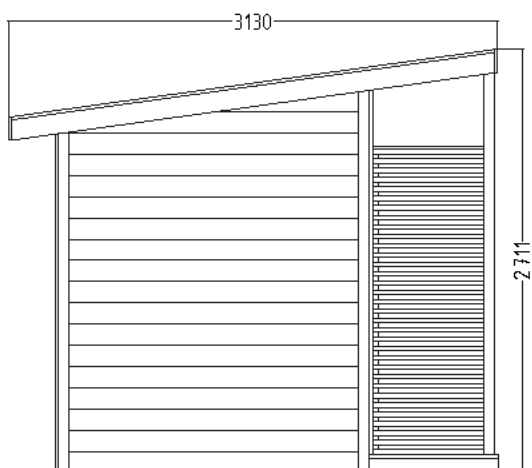
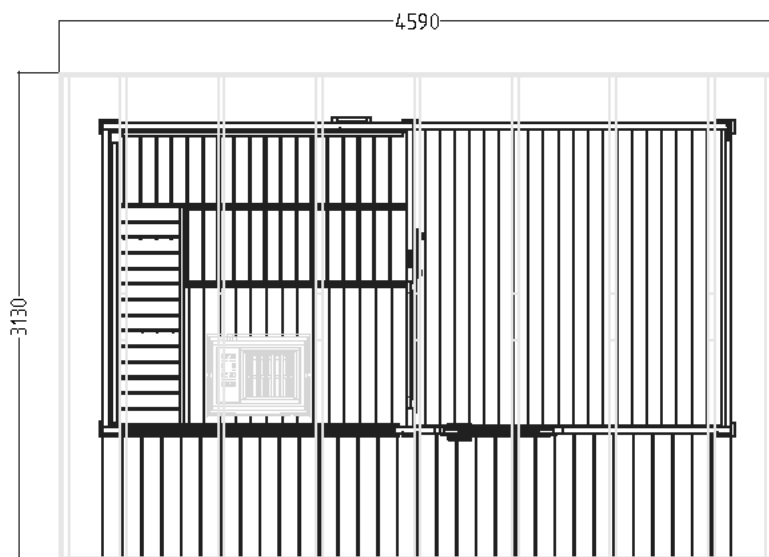

4. Montage de la cabine



ATTENTION !

Référez-vous aux plans des pages page 11 et aux illustrations à partir de la page 15.

4.1. Montage du cadre de base

Placez le cadre de base imprégné sur la fondation comme indiqué sur le plan de construction et les illustrations de la fondation (voir pages 11 et 12). Collez le cadre de base aux angles et vissez les éléments ensemble avec 5 vis de 90 mm.

4.2. Montage de la structure porteuse du plancher

Placez le cadre de plancher imprégné dans la cabine et vissez-le au cadre de base.



Veillez à la pose correcte des câbles et au bon positionnement des bois courts du plancher (272x100x40) pour garantir le durcissement de la surface de positionnement du poêle !

4.3. Montage des parois de la cabine

Commencez par le montage des madriers sur la paroi arrière. Procédez ligne par ligne. Comme pour le cadre de base, collez et vissez les coins ensemble. Enfoncez les goupilles en fer dans les trous pré-perçés de chaque rangée.



Vérifiez que les angles sont droits avant de visser les madriers au niveau des coins (remarque page 4).
Veillez à ce que les registres d'aération soient bien positionnés à la 2^e ligne !

4.4. Montage du plancher

Montage des planches du plancher

4.5. Montage de l'intérieur du toit

Montage des baguettes d'appui de toit Distance par rapport au bord supérieur : 210 mm.

Montage de l'éclairage intérieur.

Mettez les éléments du toit en place.

4.6. Montage des bancs et des dossiers

4.7. Montage des fenêtres et des portes

Insérez d'abord le cadre de la fenêtre à l'intérieur et vissez-le à la paroi de la cabine. Insérez le verre par l'extérieur et montez le deuxième cadre de fenêtre.

Placez la porte intérieure du vestibule dans l'ouverture de la porte et fixez-la en montant la garniture de la porte à l'intérieur du sauna.

Placez la porte extérieure dans l'ouverture de la porte et fixez-la en montant la garniture de porte depuis l'intérieur.

4.8. Montage des plinthes

4.9. Montage du registre d'aération

4.10. Montage de l'extérieur du toit

Collez et vissez les chevrons de toit et placez-les dans les évidements conformément à l'illustration. Vissez les chevrons aux madriers. Fixez les planches à rainure et à languettes aux chevrons.

Fixez les baguettes 82° 40x40 sur le côté des planches à languettes et à rainures et les lattes d'angle 82° 1571x150x40 par-dessus.

Fixez les lattes d'angle 2295x150x20 à l'avant et à l'arrière.

Le carton bitumé inclus dans la livraison sert de revêtement initial. Nous recommandons de recouvrir en outre la toiture de bardeaux de bitume, de tôle ou d'un film approprié.

4.11. Montage de la terrasse

Placez le cadre de base de la terrasse comme indiqué sur les photos (voir page 32) et vissez-le au cadre de base de la cabine. Montez ensuite les planches de recouvrement (825x95x25) sur le cadre de base.

Montage des planches du plancher

4.12. Montage des barres d'angle et des grilles d'aération

4.13. Montage de l'écran de protection et des supports de toit

Sauna da giardino

SCALA Grande

459 x 313 x 272 cm

ISTRUZIONI DI MONTAGGIO

Italiano



IT

Indice

1. Preparazione per il montaggio	3
1.1. Indicazioni importanti	3
1.2. Manutenzione e pulizia	4
1.3. Fondamenta	4
1.4. Ancoraggio della sauna all'aperto	5
1.5. Smaltimento	5
1.6. Attrezzi necessari	6
1.7. Elenco dei pezzi	7
2. Pianta del terreno/fondamenta	11
3. Vista/dimensioni	12
4. Montaggio cabina	13
4.1. Montaggio telaio di base	13
4.2. Montaggio sottostruttura pavimento	13
4.3. Montaggio delle pareti della cabina	13
4.4. Montaggio del pavimento	13
4.5. Montaggio del tetto interno	13
4.6. Montaggio di panche e schienali	13
4.7. Montaggio di finestre e porte	14
4.8. Montaggio degli zoccoli	14
4.9. Montaggio del pannello scorrevole di aerazione	14
4.10. Montaggio del tetto esterno	14
4.11. Montaggio della terrazza	14
4.12. Montaggio dei listelli angolari e delle griglie di ventilazione	14
4.13. Montaggio degli elementi di protezione della privacy e dei supporti del tetto	14
Figure di montaggio (dopo l'ultima lingua)	15

1. Preparazione per il montaggio

Leggere con attenzione le presenti istruzioni di montaggio e conservarle. In questo modo è possibile controllare in qualsiasi momento le informazioni relative al prodotto.



Le presenti istruzioni di montaggio sono disponibili anche nella sezione download del nostro sito web all'indirizzo: www.sentiotec.com/downloads.

1.1. Indicazioni importanti

- Informatevi presso l'autorità edilizia competente locale (ufficio comunale o autorità comunali) per i regolamenti edilizi e gli standard di carico.
- Solide fondamenta in cemento sono importanti per la durata e la sicurezza della vostra sauna all'aperto. Vi consigliamo di far eseguire le fondamenta da un professionista.
- L'ancoraggio della sauna esterna è responsabilità del cliente. Nessuna garanzia in caso di danni.
- La sauna all'aperto è consegnata da un camion (eventualmente anche da un autoarticolato). Di conseguenza è necessario assicurarsi che sia possibile l'accesso al luogo di scarico.
- Prima di iniziare i lavori, controllare in base all'elenco dei pezzi se tutti i singoli componenti sono stati effettivamente forniti. Se eccezionalmente dovessero mancare dei singoli componenti, contattare il proprio fornitore entro 14 giorni dal ricevimento della cabina.
- Conservate la bolla di consegna, la fattura e le istruzioni di montaggio in un luogo sicuro per eventuali domande.
- Per il montaggio è richiesto l'aiuto di una seconda persona.
- Tutte le connessioni a vite devono essere preforate.



Attenzione!

Il collegamento elettrico deve essere eseguito da elettricisti specializzati o da persone con una qualifica simile.

- Il cartone catramato in dotazione serve come copertura iniziale. Si consiglia di coprire ulteriormente il tetto con tegole bituminose, lamiera o una lamina adatta.
- Il legno è un prodotto naturale che può gonfiarsi, ritirarsi o deformarsi anche se immagazzinato correttamente. In fase di montaggio potrebbe quindi essere necessario applicare una certa forza.

- Il legno della sauna esterna non è trattato. Per aumentare la durata di vita, si consiglia di dipingere l'esterno con una vernice protettiva per legno adatta.
- I componenti in legno da utilizzare all'interno non devono essere trattati con vernice.

1.2. Manutenzione e pulizia

- La sauna all'interno deve essere pulita con un panno umido. Utilizzare solo acqua calda senza detergenti.
- Se la sauna non viene utilizzata per un tempo prolungato, si consiglia di riscaldare la cabina una volta al mese.



Le tasche di resina non sono motivo di reclamo perché nel legno di abete rosso sono sempre presenti e durante la selezione non è possibile rilevare a quale profondità si trovino.

Quando sono appena al di sotto della superficie, con lo sviluppo del calore si rompono e possono "essudare".

Rimuovere la resina fuoriuscita con un panno imbevuto di acetone. Se sono presenti solo gocce di resina, lasciarle indurire e poi raschiarle con cautela usando un coltello.

1.3. Fondamenta

I seguenti elementi per le fondamenta hanno dimostrato la loro efficacia nella pratica:

- piastra di fondazione (piastra di base)
- striscia di fondazione

Con entrambe le varianti, devono essere garantite fondamenta perfettamente orizzontali e portanti. Solo in questo modo è possibile garantire una perfetta installazione della sauna esterna con un adattamento esatto.

Si consiglia di usare del nastro di catrame tra il legno del basamento e il cemento per evitare che l'umidità penetri nel legno.

1.4. Ancoraggio della sauna all'aperto

È molto importante che la sauna all'aperto sia saldamente ancorata alla piastra di fondo o alla striscia di fondazione. In caso di vento forte, grandi forze possono agire sulla casetta da giardino. Per evitare danni alla vostra proprietà o a quella di altri, un ancoraggio professionale è assolutamente necessario.

Vorremmo sottolineare che l'ancoraggio della casetta da giardino è di responsabilità del cliente e non ci assumiamo nessuna responsabilità per eventuali danni.

1.5. Smaltimento



- Smaltire i materiali dell'imballaggio conformemente alle normative sullo smaltimento vigenti.

1.6. Attrezzi necessari

- Martello e pezzo di legno oppure martello in gomma
- Avvitatore elettrico con punte per viti con testa a croce e viti Torx
- Metro a nastro avvolgibile
- Punta per trapano da 3 mm, 10 mm, 20-30 mm
(per cavo elettrico della stufa per sauna)
- Livella a bolla
- Chiave a brugola da 1,5 mm
- Cutter
- Scala



Questo simbolo indica consigli e indicazioni utili



Preforatura



Taglio alla lunghezza effettiva mediante seghetto



Verifica dell'ortogonalità:

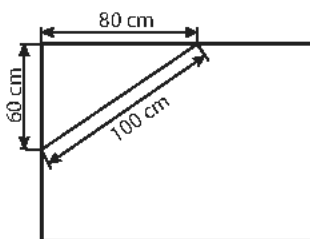

Maneggiare il vetro con cura: particolare attenzione deve essere prestata ai bordi del vetro - il vetro temprato può frantumarsi in piccoli pezzi in caso di impatto. Inserire un cuscino di protezione (ad es: scatola di cartone) sotto il bordo del vetro.

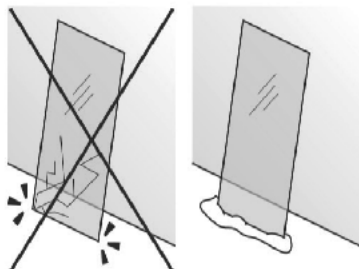

1.7. Elenco dei pezzi

N. di articoli	Nome	Dimensioni mm
Telaio base		
2	Telaio di base (impregnato)	2080x40x146
2	Telaio di base (impregnato)	1990x40x146
1	Telaio di base (impregnato) parete centrale	1910x40x146
2	Telaio di base (impregnato)	1910x40x146
W1: Lato anteriore con finestra e porta		
1	Trave per Blockhaus con fori per l'aria di alimentazione	2160x146x40
9	Trave per Blockhaus	2160x146x40
14	Trave per Blockhaus	1040x146x40
3	Trave per Blockhaus	118x146x40
3	Trave per Blockhaus	287x146x40
2	Trave per Blockhaus	1990x146x40
2	Trave per Blockhaus	2080x146x40
1	Trave per Blockhaus sotto la finestra	2160x146x40
1	Trave per Blockhaus sopra la finestra	1990x146x40
1	Trave per Blockhaus sopra la porta	2080x146x40
1	Trave per Blockhaus con fori per l'areazione	1990x131x40
1	Trave per Blockhaus con fori per l'areazione	2080x131x40
W2: Pannello laterale		
15	Trave per Blockhaus	1910x146x40
1	Trave per Blockhaus del triangolo superiore	1910x397x40
W3: Pannello posteriore		
1	Trave per Blockhaus con fori per l'aria di scarico	1990x146x40
14	Trave per Blockhaus	1990x146x40
15	Trave per Blockhaus	2080x146x40
1	Trave per Blockhaus con fori per l'areazione	1990x131x40
1	Trave per Blockhaus con fori per l'areazione	2080x131x40
W4: Pannello laterale		
15	Trave per Blockhaus	1910x146x40
1	Trave per Blockhaus del triangolo superiore	1910x397x40
W5: Pannello centrale		
14	Trave per Blockhaus	110x146x40
13	Trave per Blockhaus con foro per il cavo	980x146x40
1	Trave per Blockhaus con foro per il cavo	980x146x40
1	Trave per Blockhaus sopra la porta	1910x146x40
1	Trave per Blockhaus del triangolo superiore	1910x397x40

N. di articoli	Nome	Dimensioni mm
Pavimento		
7	Telaio del pavimento (impregnato)	1905x100x40
7	Telaio del pavimento (impregnato)	1995x100x40
6	Telaio del pavimento (impregnato)	272x100x40
41	Tavole del pavimento	1900x95x19
1	Tavole del pavimento con apertura	1900x60x19
1	Tavole del pavimento con apertura	1900x60x19
4	Zoccolo	1910x25x20
1	Zoccolo	2000x25x20
1	Zoccolo	950x25x20
1	Zoccolo	965x25x20
1	Zoccolo	970x25x20
1	Zoccolo	95x25x20
1	Zoccolo	140x25x20
1	Zoccolo	80x25x20
2	Zoccolo	780x25x20
Coperture angolari		
10	Copertura angolare	1000x80x20
2	Copertura angolare	1630x80x20
2	Copertura angolare a 82°	1630x80x20
1	Copertura angolare con apertura	1630x80x20
2	Copertura angolare	1360x80x20
2	Copertura angolare a 82°	1360x80x20
1	Copertura angolare con apertura	1360x80x20
Tetto interno		
1	Pannello del tetto	1890x955x55
1	Pannello del tetto	1890x955x55
1	Pannello del tetto	1980x955x55
1	Pannello del tetto	1980x955x55
1	Listello di supporto del tetto a 82°	1910x40x40
1	Listello di supporto del tetto a 82°	2000x40x40
1	Listello di supporto tetto	1910x40x40
1	Listello di supporto tetto	2000x40x40
2	Listello di supporto del tetto 2x82° a sinistra	1847x40x40
2	Listello di supporto del tetto 2x82° a destra	1847x40x40

N. di articoli	Nome	Dimensioni mm
Tetto esterno		
7	Falsi puntoni a 82°	1719x130x40
7	Falsi puntoni a 82°	1719x130x40
2	Listelli antivento listelli di supporto a 82° superiori	2000x40x40
2	Listelli antivento listelli di supporto a 82° inferiori	1126x40x40
66	Perline maschio-femmina per il tetto	2275x95x19
2	Listelli antivento a 82° laterali inferiori	1571x150x20
2	Listelli antivento a 82° laterali superiori	1571x150x20
4	Listelli antivento	2295x150x20
1	Supporto del tetto a sinistra	2550x70x70
1	Supporto del tetto a destra	2550x70x70
Porta esterna		
1	Porta esterna incluso telaio della porta	1955x890x70
2	Pannello della porta interno	1950x55x20
1	Pannello della porta interno	780x55x20
Porta interna		
1	Vetro incl. cornice	1900x820x50
2	Pannello della porta interno	2020x55x20
1	Pannelli porta interni	750x55x20
Finestra		
1	Vetro di sicurezza isolante	1587x506x16
2	Telaio della finestra	1805x560x32
Allestimento interno		
1	Panca	1900x600x88
1	Panca	1900x500x88
1	Panca	1305x600x88
2	Schienale	1800x220x48
2	Listelli di supporto panca	955x88x28
3	Listelli di supporto panca	595x88x28
2	Griglia di protezione stufa	1000x88x28
1	Griglia di protezione stufa	490x70x28
1	Griglia di protezione stufa	675x70x28
1	Griglia di sicurezza della stufa (sostegno)	575x88x28

N. di articoli	Nome	Dimensioni mm
Terrazza		
6	Telaio di base (impregnato)	2090x95x40
32	Tavole della terrazza	825x120x25
2	Listello di copertura	825x95x25
2	Elemento protezione della privacy	1970x780x60
2	Supporti per il tetto	2550x70x70
Accessori		
2	Cursore di ventilazione 620P	215x170x20
2	Griglia di ventilazione	250x250x30
2	Poggiatesta 520S	430x250x70
1	Griglia di protezione della lampada 920S	
1	Lampada senza lampadina	
2	Adesivo polimerico (290 ml)	
12	Griglia di ventilazione in acciaio inox	
2	Angolo di metallo	60x60x3
146	Pemi di ferro	120x12x2
2	Cartone catramato	
1	Set di materiale di montaggio	
1	Istruzioni di montaggio	

2. Pianta del terreno/fondamenta

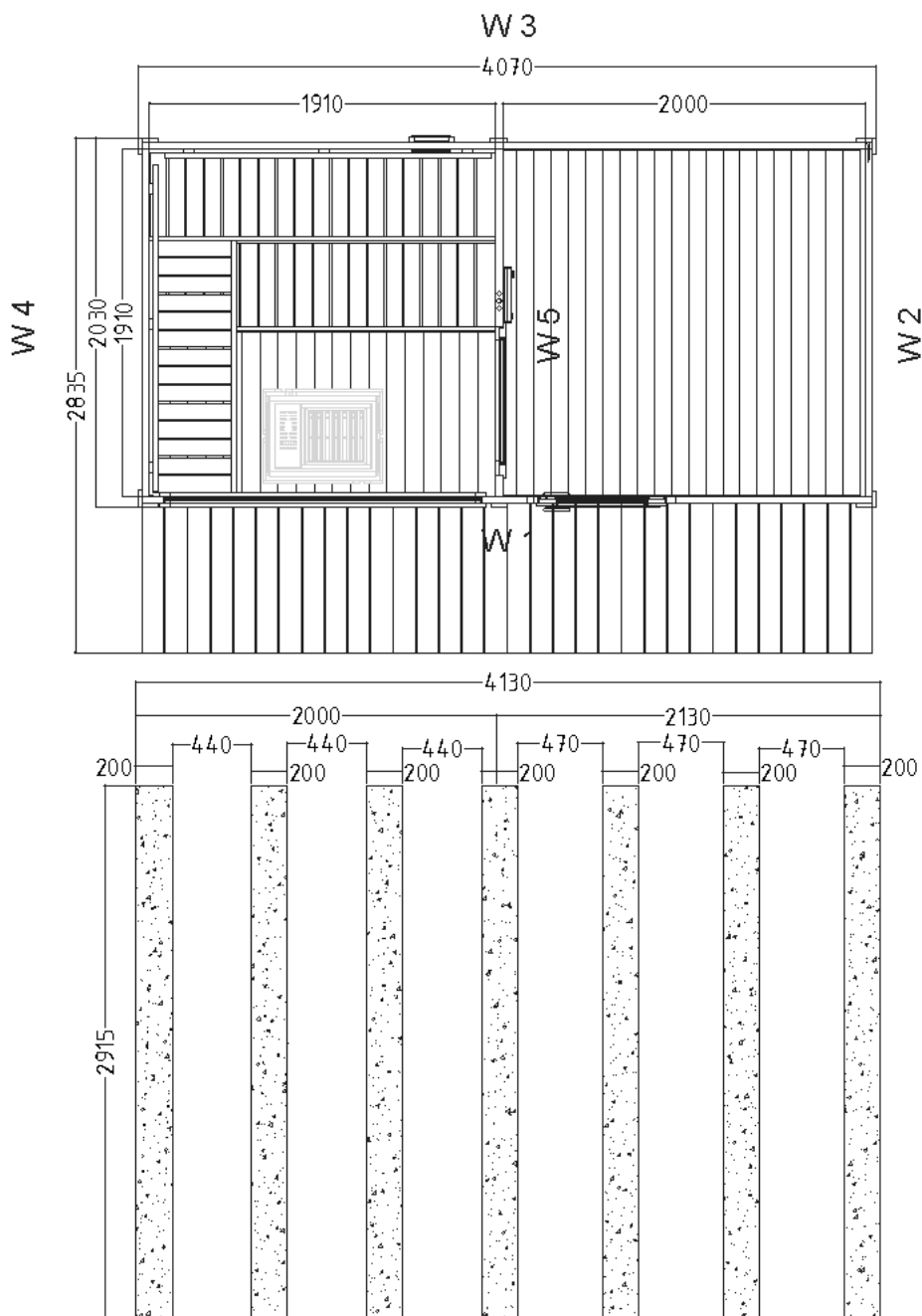

3. Vista/dimensioni

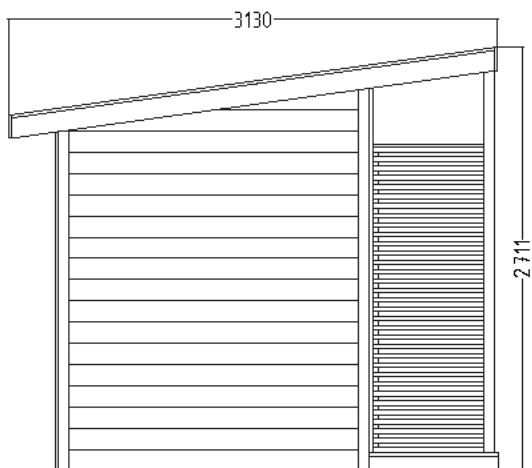
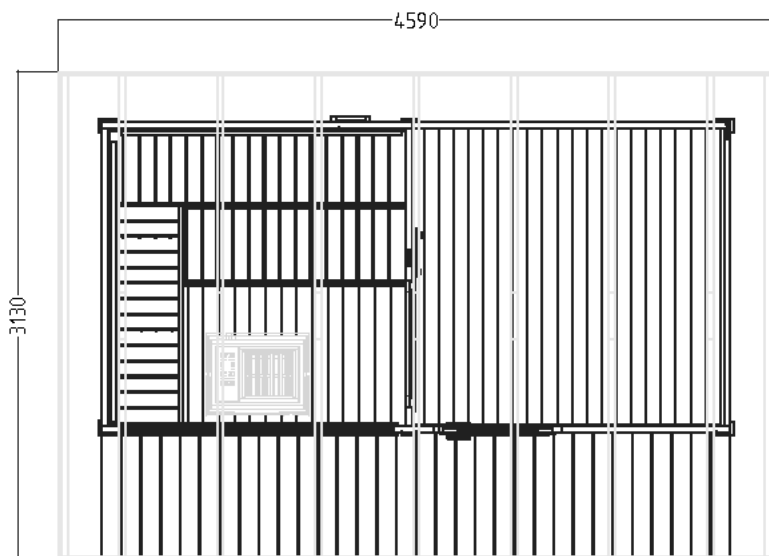

4. Montaggio cabina



ATTENZIONE!

Osservate la pianta a pagina 11 e le illustrazioni da pagina 15.

4.1. Montaggio telaio di base

Posizionare il telaio di base impregnato sulle fondamenta come mostrato nella pianta e nelle illustrazioni delle fondamenta (vedi pagine 11 e 12). Incollare il telaio di base agli angoli e avvitare i pezzi con 5 viti da 90 mm.

4.2. Montaggio sottostruttura pavimento

Posizionare il telaio del pavimento impregnato nella cabina e avvitarlo al telaio di base.



Osservare la posa dei cavi e la posizione delle travi corte del pavimento (272 x 100 x 40) per rinforzare la superficie d'appoggio della stufa!

4.3. Montaggio delle pareti della cabina

Iniziare con il montaggio delle travi per Blockhaus sul pannello posteriore. Procedere riga per riga. Come per il telaio di base, incollare e avvitare gli angoli. Inserire con un martello i perni di ferro nei fori preforati per ogni fila.



Controllare l'ortogonalità prima di avvitare le travi per Blockhaus sugli angoli (nota a pagina 4).

Osservare la posizione dei cursori di ventilazione nella fila 2!

4.4. Montaggio del pavimento

Montaggio delle tavole del pavimento.

4.5. Montaggio del tetto interno

Montaggio dei listelli di supporto del tetto. Distanza dal bordo superiore: 210 mm.

Montaggio dell'illuminazione interna.

Inserire gli elementi del tetto.

4.6. Montaggio di panche e schienali

4.7. Montaggio di finestre e porte

Per prima cosa inserite il telaio della finestra all'interno e avvitatelo alla parete della cabina. Inserire il vetro dall'esterno e montare il secondo telaio della finestra.

Posizionare la porta interna dell'anticamera nell'apertura della porta e fissarla montando il rivestimento interno della porta dall'interno della sauna.

Posizionare la porta esterna nell'apertura della porta e fissarla montando il rivestimento della porta dall'interno.

4.8. Montaggio degli zoccoli

4.9. Montaggio del pannello scorrevole di aerazione

4.10. Montaggio del tetto esterno

Incollare e avvitare i falsi puntoni e metterli come da figura nelle cavità. Avvitare i falsi puntoni con le travi per Blockhaus. Fissare le perline maschio-femmina sui falsi puntoni.

Fissare i listelli a 82° - 40x40 lateralmente alle perline maschio-femmina e sopra i listelli antivento a 82° - 1571x150x40.

Fissare i listelli antivento 2295x150x20 anteriori e posteriori.

Il cartone catramato in dotazione serve come copertura iniziale. Si consiglia di coprire ulteriormente il tetto con tegole bituminose, lamiera o una lamina adatta.

4.11. Montaggio della terrazza

Posizionare il telaio di base della terrazza come mostrato nelle foto (vedi pagina 32) e avvitare al telaio di base della cabina. Poi montate le tavole di copertura (825x95x25) sul telaio di base.

Montaggio delle tavole del pavimento.

4.12. Montaggio dei listelli angolari e delle griglie di ventilazione

4.13. Montaggio degli elementi di protezione della privacy e dei supporti del tetto

Tuinsauna

SCALA Large

459 x 313 x 272 cm

MONTAGEANLEITUNG
Nederlands



NL

Inhoudsopgave

1. Montagevoorbereiding	3
1.1. Belangrijke aanwijzingen	3
1.2. Onderhoud en reiniging	4
1.3. Fundering	4
1.4. Verankering van de buitensauna	5
1.5. Afvoer	5
1.6. Vereist gereedschap	6
1.7. Stuklijst	7
2. Plattegrond / fundering	11
3. Aanzicht / afmetingen	12
4. Montage cabine	13
4.1. Montage basisframe	13
4.2. Montage onderconstructie bodem	13
4.3. Montage cabinewanden	13
4.4. Montage vloer	13
4.5. Montage binnendak	13
4.6. Montage banken en rugleuning	13
4.7. Montage ramen en deuren	14
4.8. Montage van de sokkellijsten	14
4.9. Montage ventilatieschuif	14
4.10. Montage buitendak	14
4.11. Montage van het terras	14
4.12. Montage van de hoeklatten en ventilatieroosters	14
4.13. Montage van het privacy scherm en de daksteunen	14
Montageafbeeldingen (na de laatste taal)	15

1. Montagevoorbereiding

Lees deze montagehandleiding goed door en bewaar hem goed. Zo kunt u te allen tijde productinformatie nalezen.



U vindt deze montagehandleiding ook op onze website,
www.sentiotec.com/downloads.

1.1. Belangrijke aanwijzingen

- Informeer u bij uw verantwoordelijke bouwinstantie (gemeentekantoor, magistraat) naar de bouwvoorschriften en belastingsnomen.
- Een solide betonfundering is belangrijk voor de houdbaarheid en de veiligheid van uw buitensauna. Wij adviseren u om de fundering door een vakbedrijf te laten aanleggen.
- Voor de verankering van de buitensauna is de klant verantwoordelijk. Geen garantie bij eventuele schade.
- De buitensauna wordt op een vrachtwagen (eventueel op een oplegger) geleverd. Hierbij moet ervoor gezorgd zijn dat de toegang tot de losplaats mogelijk is.
- Controleer alvorens met de montage te beginnen aan de hand van de stuklijst of alle afzonderlijke delen werden geleverd. Als er delen ontbreken, neem dan uiterlijk 14 dagen na ontvangst van de cabine contact op met uw handelaar.
- Bewaar het afleveringsbewijs, de factuur en de montagehandleiding voor eventuele vragen.
- De montage moet door twee personen worden uitgevoerd.
- Alle schroefverbindingen moeten worden voorgeboord.



Let op!

De elektrische aansluiting mag alleen worden uitgevoerd door een elektricien of een vergelijkbaar gekwalificeerd persoon.

- Het meegeleverde dakviilt dient als voorlopige dakbedekking. Wij adviseren om het dak aanvullend te bedekken met bitumen dakspanen, plaatstaal of een geschikte folie.
- Hout is een natuurlijk product dat ondanks correcte opslag kan uitzetten, krimpen of krom trekken. Daardoor kan het zijn dat bij de montage kracht moet worden toegepast.

- Het hout van de buitensauna is onbehandeld. Om de levensduur te verlengen, adviseren we om deze vanbuiten te behandelen met een geschikte houtverf.
- De houten onderdelen die binnen worden gebruikt, mogen niet met verf worden behandeld.

1.2. Onderhoud en reiniging

- De sauna moet vanbinnen met een vochtige doek worden gereinigd. Gebruik alleen warm water, geen reinigingsmiddel.
- Als de sauna voor langere tijd niet wordt gebruikt, adviseren wij de cabine een keer per maand te verwarmen.



Harsbuilen gelden niet als reclamatierefen. Omdat in sparrenhout van nature harsbuilen kunnen voorkomen en bij het sorteren niet kan worden herkend in welke diepte ze zich bevinden.

Als ze zich net onder het oppervlak bevinden, kunnen ze bij hitte openbreken en gaan 'bloeden'.

De uitgelopen hars kan met een in aceton gedompelde doek worden verwijderd. Als alleen harsdruppels ontstaan, deze laten uitharden en met een mes voorzichtig wegschrappen.

1.3. Fundering

In de praktijk is gebleken dat deze funderingen goed zijn:

- Funderingsplaat (gietplaat)
- Strokenfundering

Beide varianten moeten absoluut horizontaal zijn en over voldoende draagvermogen beschikken. Alleen zo kan een correcte en precies passende montage van de buitensauna worden gegarandeerd.

Wij adviseren om teerband te gebruiken tussen de houten sokkel en het beton om te voorkomen dat er vocht in het hout dringt.

1.4. Verankering van de buitensauna

Het is heel belangrijk dat de buitensauna in de gietplaat of de strokenfundering wordt verankerd. Bij sterke wind kunnen er grote krachten op de buitensauna inwerken. Om beschadiging van eigen of andermans eigendom te voorkomen is een deskundige verankering noodzakelijk.

Wij wijzen erop dat de klant zelf verantwoordelijk is voor de verankering van de buitensauna en wij niet aansprakelijk kunnen worden gesteld voor eventuele schade.

1.5. Afvoer



- Voer het verpakkingsmateriaal af volgens de geldende afvoerrichtlijnen.

1.6. Vereist gereedschap

- Hamer en slaghout of een rubberhamer
- Accuschroefmachine met bits voor kruiskopschroeven en torx
- Rolmaat
- Boren met diameters 3 mm, 10 mm, 20 - 30 mm (voor stroomkabel van saunakachel)
- Waterpas
- Inbussleutel 1,5 mm
- Universeel mes
- Ladder



Dit symbool kenmerkt tips en nuttige aanwijzingen



Vorboren



Inkorten met kapzaag



Controle van de rechte hoek:

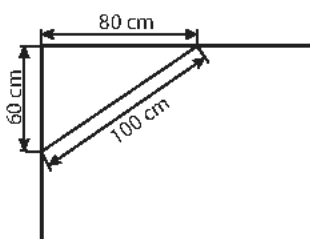

Voorzichtige omgang met glas: met de glazen randen dient u bijzonder voorzichtig om te gaan – gehard glas kan door stoten in kleine scherven versplinteren. Leg een beschermende ondergrond (bijv.: verpakkingskarton) onder de glazen rand.

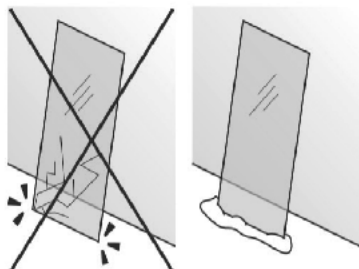

1.7. Stuklijst

Aantal items	Naam	Afmetingen mm
Basisframe		
2	Basisframe (geïmpregneerd)	2080x40x146
2	Basisframe (geïmpregneerd)	1990x40x146
1	Basisframe (geïmpregneerd) middenwand	1910x40x146
2	Basisframe (geïmpregneerd)	1910x40x146
W1: Voorzijde met raam en deur		
1	Blokplank met boringen voor toevoerlucht	2160x146x40
9	Blokplank	2160x146x40
14	Blokplank	1040x146x40
3	Blokplank	118x146x40
3	Blokplank	287x146x40
2	Blokplank	1990x146x40
2	Blokplank	2080x146x40
1	Blokplank onder het raam	2160x146x40
1	Blokplank boven het raam	1990x146x40
1	Blokplank boven de deur	2080x146x40
1	Blokplank met boringen voor ventilatie	1990x131x40
1	Blokplank met boringen voor ventilatie	2080x131x40
W2: Zijwand		
15	Blokplank	1910x146x40
1	Blokplank bovenste driehoek	1910x397x40
W3: Achterwand		
1	Blokplank met boringen voor afvoerlucht	1990x146x40
14	Blokplank	1990x146x40
15	Blokplank	2080x146x40
1	Blokplank met boringen voor ventilatie	1990x131x40
1	Blokplank met boringen voor ventilatie	2080x131x40
W4: Zijwand		
15	Blokplank	1910x146x40
1	Blokplank bovenste driehoek	1910x397x40
W5: Middenwand		
14	Blokplank	110x146x40
13	Blokplank met boring voor kabel	980x146x40
1	Blokplank met boring voor kabel	980x146x40
1	Blokplank boven de deur	1910x146x40
1	Blokplank bovenste driehoek	1910x397x40

Aantal items	Naam	Afmetingen mm
Vloer		
7	Bodemframe (geïmpregneerd)	1905x100x40
7	Bodemframe (geïmpregneerd)	1995x100x40
6	Bodemframe (geïmpregneerd)	272x100x40
41	Vloerplanken	1900x95x19
1	Vloerplanken met uitsnede	1900x60x19
1	Vloerplanken met uitsnede	1900x60x19
4	Sokkellijst	1910x25x20
1	Sokkellijst	2000x25x20
1	Sokkellijst	950x25x20
1	Sokkellijst	965x25x20
1	Sokkellijst	970x25x20
1	Sokkellijst	95x25x20
1	Sokkellijst	140x25x20
1	Sokkellijst	80x25x20
2	Sokkellijst	780x25x20
Hoekafdekkingen		
10	Hoekafdekking	1000x80x20
2	Hoekafdekking	1630x80x20
2	Hoekafdekking 82°	1630x80x20
1	Hoekafdekking met uitsnede	1630x80x20
2	Hoekafdekking	1360x80x20
2	Hoekafdekking 82°	1360x80x20
1	Hoekafdekking met uitsnede	1360x80x20
Dak binnen		
1	Dakpaneel	1890x955x55
1	Dakpaneel	1890x955x55
1	Dakpaneel	1980x955x55
1	Dakpaneel	1980x955x55
1	Daksteunlat 82°	1910x40x40
1	Daksteunlat 82°	2000x40x40
1	Daksteunlat	1910x40x40
1	Daksteunlat	2000x40x40
2	Daksteunlat 2x82° links	1847x40x40
2	Daksteunlat 2x82° rechts	1847x40x40

Aantal items	Naam	Afmetingen mm
Dak buiten		
7	Dakspant 82°	1719x130x40
7	Dakspant 82°	1719x130x40
2	Windlatten ondersteuningslatten 82° boven	2000x40x40
2	Windlatten ondersteuningslatten 82° onder	1126x40x40
66	Dak messing-en-groefplanken	2275x95x19
2	Windlatten 82° zijdelings onder	1571x150x20
2	Windlatten 82° zijdelings boven	1571x150x20
4	Windlatten	2295x150x20
1	Daksteun links	2550x70x70
1	Daksteun rechts	2550x70x70
Buitendeur		
1	Buitendeur incl. deurkozijn	1955x890x70
2	Deurbekleding binnen	1950x55x20
1	Deurbekleding binnen	780x55x20
Binnendeur		
1	Glas incl. kozijn	1900x820x50
2	Deurbekleding binnen	2020x55x20
1	Deurbekledingen binnen	750x55x20
Window		
1	Isolerend veiligheidsglas	1587x506x16
2	Raamkozijn	1805x560x32
Binneninrichting		
1	Bank	1900x600x88
1	Bank	1900x500x88
1	Bank	1305x600x88
2	Rugleuning	1800x220x48
2	Steunlijsten bank	955x88x28
3	Steunlijsten bank	595x88x28
2	Kachelbeschermingsrooster	1000x88x28
1	Kachelbeschermingsrooster	490x70x28
1	Kachelbeschermingsrooster	675x70x28
1	Kachelbeschermingsrooster (schoor)	575x88x28

Aantal items	Naam	Afmetingen mm
Terras		
6	Basisframe (geïmpregneerd)	2090x95x40
32	Terrasplanken	825x120x25
2	Afdeklát	825x95x25
2	Privacyscherm	1970x780x60
2	Daksteunen	2550x70x70
Toebehoren		
2	Ventilatieschuif 620P	215x170x20
2	Ventilatioerooster	250x250x30
2	Hoofdsteun 520S	430x250x70
1	Lampbeschermingsrooster 920S	
1	Lamp zonder lichtbron	
2	Polymeerlijm (290ml)	
12	Edelstaal ventilatioerooster	
2	Metalen hoek	60x60x3
146	IJzeren pennen	120x12x2
2	Dakvilt	
1	Set montagemateriaal	
1	Montagehandleiding	

2. Plattegrond / fundering

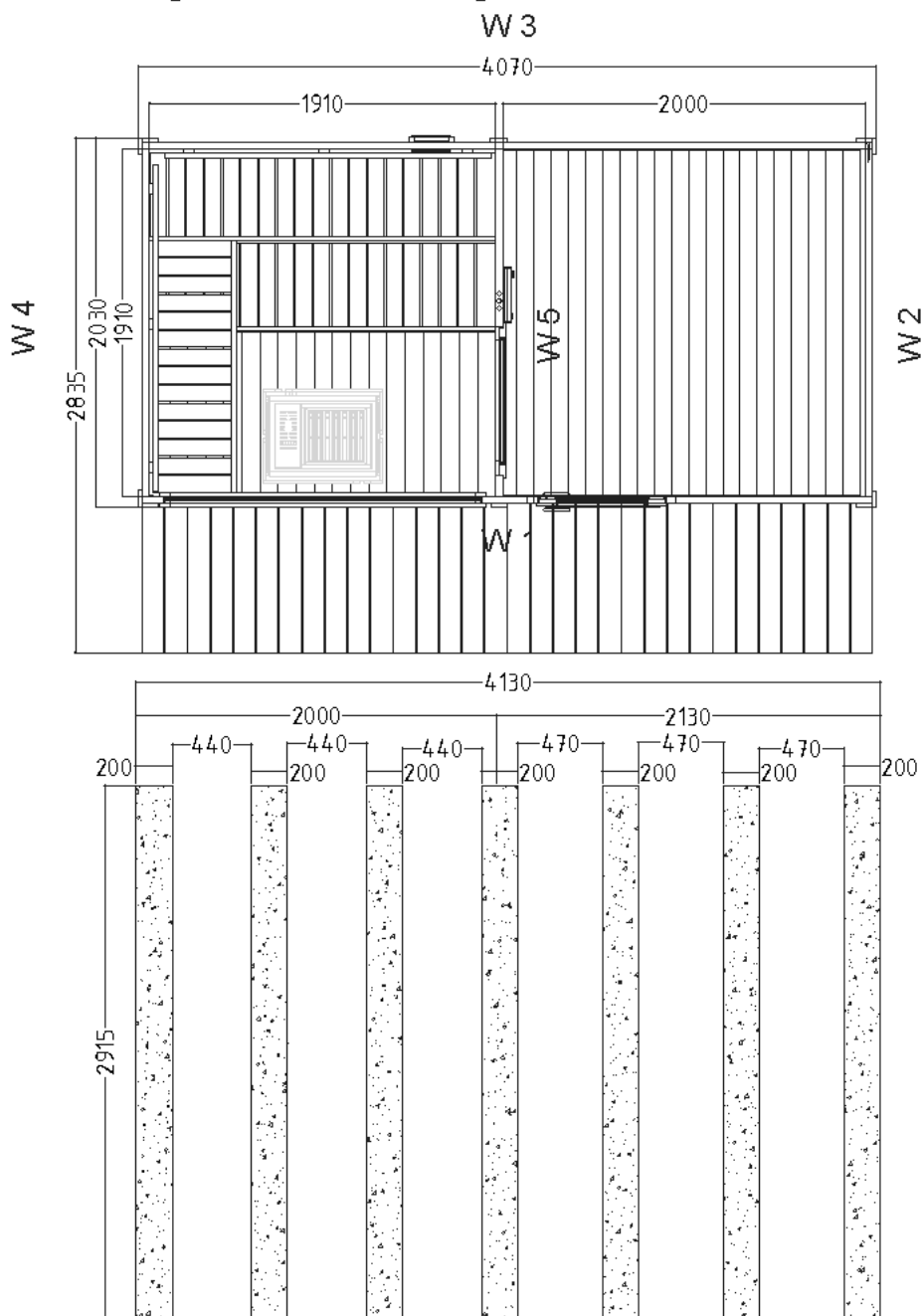

3. Aanzicht / afmetingen

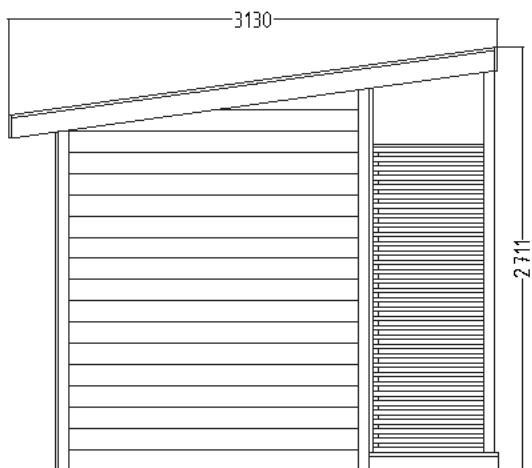
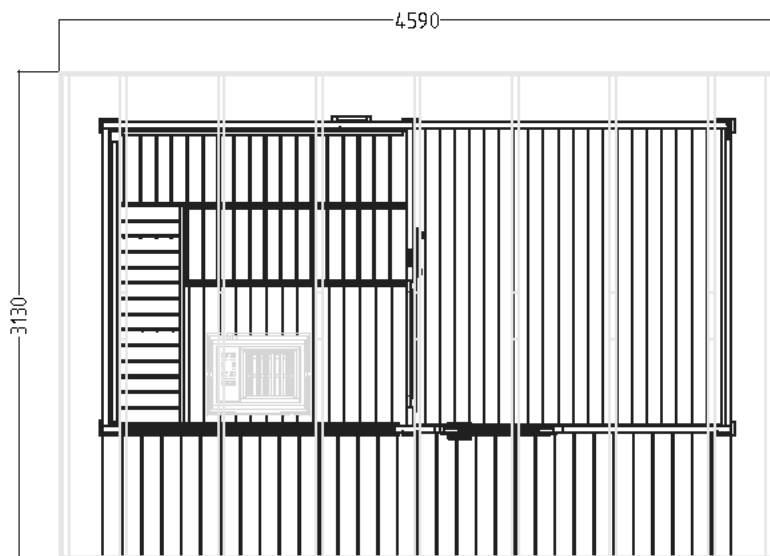

4. Montage cabine

**LET OP!**

Neem de plattegronden op pagina 11 en de afbeelding vanaf pagina 15 in acht.

4.1. Montage basisframe

Leg het geïmpregneerde basisframe op de fundering zoals afgebeeld op de plattegrond en in de funderingsafbeeldingen (zie pagina 11 en 12). Lijm het bodemframe aan de hoeken en schroef de onderdelen vast met schroeven 5 x 90 mm.

4.2. Montage onderconstructie bodem

Leg het geïmpregneerde bodemframe in de cabine en schroef dit vast aan het basisframe.



Let op het verloop van de kabels en de positie van de korte vloerplanken (272 x 100 x 40) ter versterking van het kachel-opstelvlak!

4.3. Montage cabinewanden

Begin met de montage van de blokplanken aan de achterwand. Ga rij voor rij te werk. Net als bij het basisframe lijmt u de hoeken, daarna schroeft u ze vast. Sla bij elke rij de ijzeren pennen in de voorgeboorde gaten.



Controleer de rechte hoek alvorens de blokplanken aan de hoeken vast te schroeven (aanwijzing pagina 4).

Let op de positie van de ventilatieschuiven in rij 2!

4.4. Montage vloer

Montage van de vloerplanken.

4.5. Montage binnendak

Montage van de daksteunlatten. Afstand tot de bovenzijde: 210 mm.

Montage van de binnenverlichting.

Leg de dakelementen erin.

4.6. Montage banken en rugleuning

4.7. Montage ramen en deuren

Plaats eerst het raamkozijn aan de binnenzijde en schroef het vast aan de cabine wand. Plaats het glas er vanaf buiten in en monteer het tweede raamkozijn.

Plaats de binnendeur vanuit de voorruimte in de deuropening en zet deze vast door de montage van de deurbekleding binnen aan de binnenzijde van de sauna.

Plaats de buitendeur in de deuropening en zet deze vast door de montage van de deurbekleding vanuit de binnenzijde.

4.8. Montage van de sokkellijsten

4.9. Montage ventilatieschuif

4.10. Montage buitendak

Lijm de dakspanten en schroef deze vast. Leg ze dan zoals in de afbeelding in de uitsparingen. Schroef de dakspanten vast aan de blokplanken. Bevestig de messing-en-groefplanken aan de dakspanten.

Bevestig de latten 82° - 40x40 aan de zijkant aan de messing-en-groefplanken en daarop de windlatten 82° - 1571x150x40.

Bevestig de windlatten 2295x150x20 vooraan en achteraan.

Het bijgeleverde dakvilt dient als voorlopige dakbedekking. Wij adviseren om het dak aanvullend te bedekken met bitumen dakspanen, plaatstaal of een geschikte folie.

4.11. Montage van het terras

Leg het basisframe van het terras zoals op de foto's (zie pagina 32), en schroef ze vast aan het basisframe van de cabine. Monteer vervolgens de afdekplanken (825x95x25) op het basisframe.

Montage van de vloerplanken.

4.12. Montage van de hoeklatten en ventilatieroosters

4.13. Montage van het privacyscherm en de daksteunen

4.1.

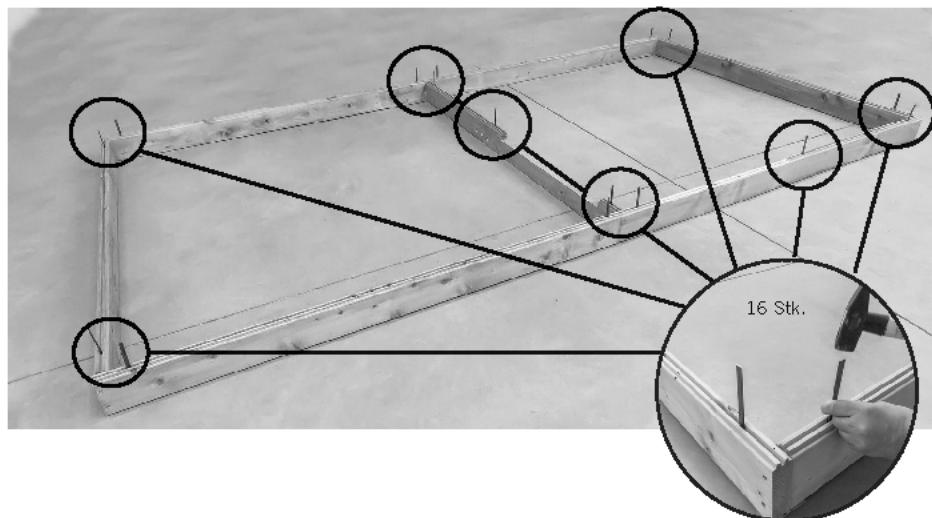
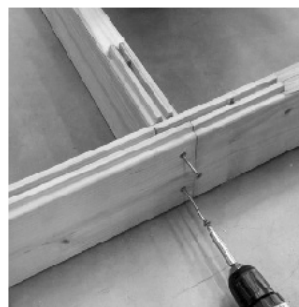
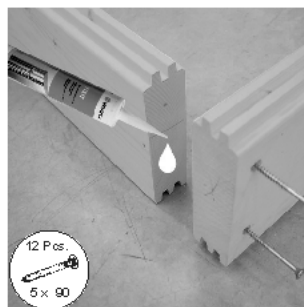
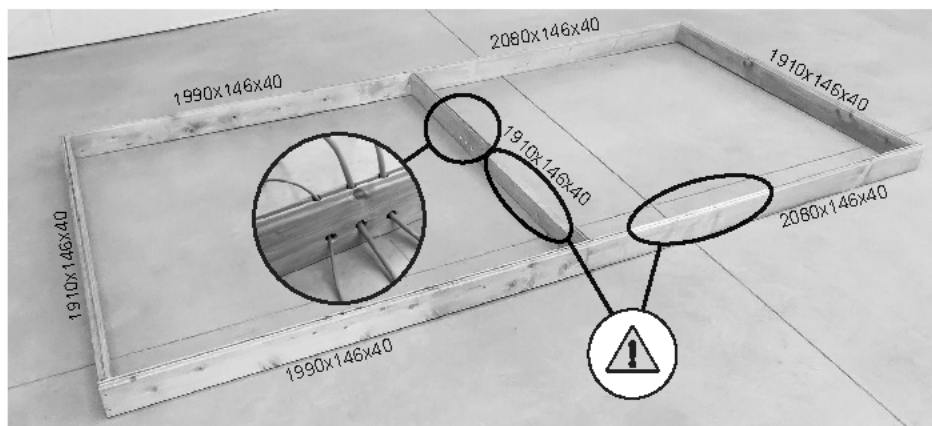

4.2.

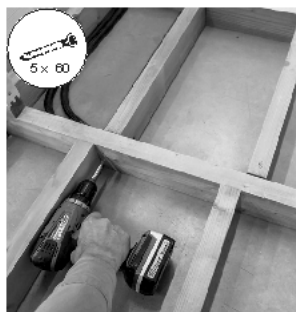
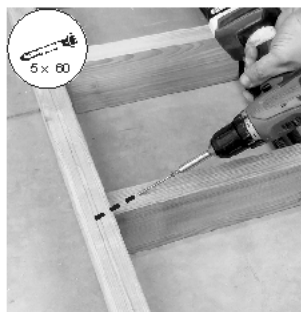

4.3.



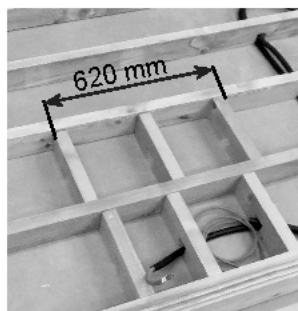
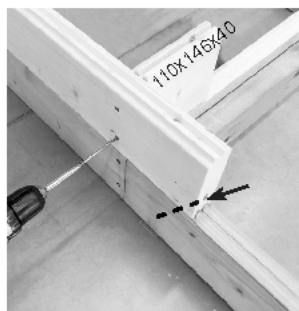
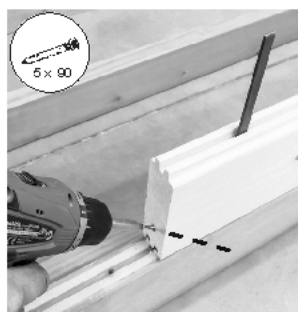
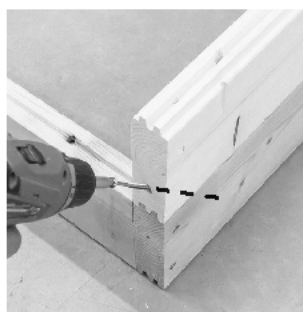
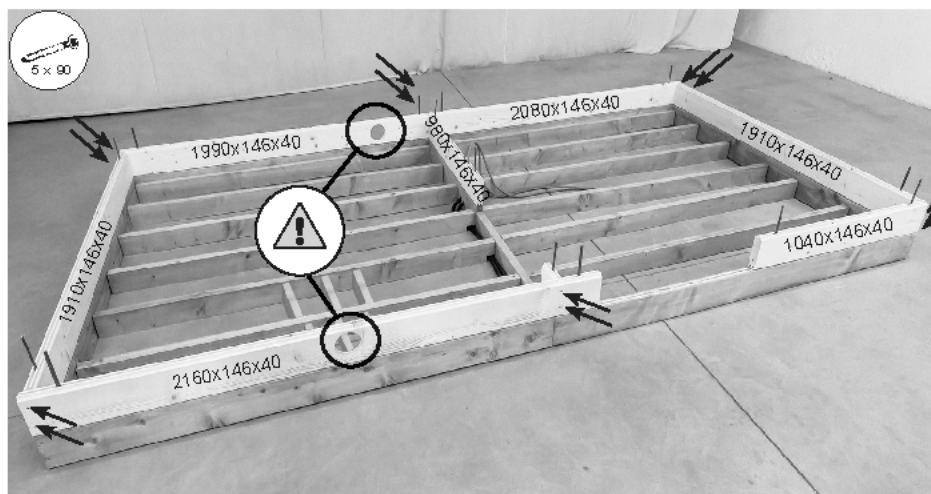



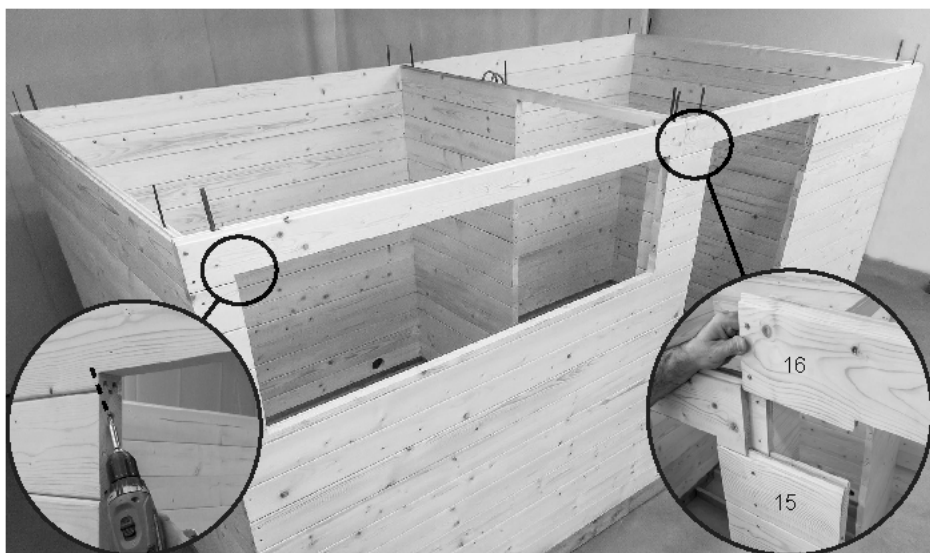
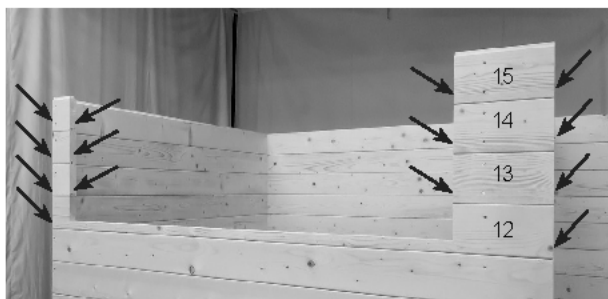
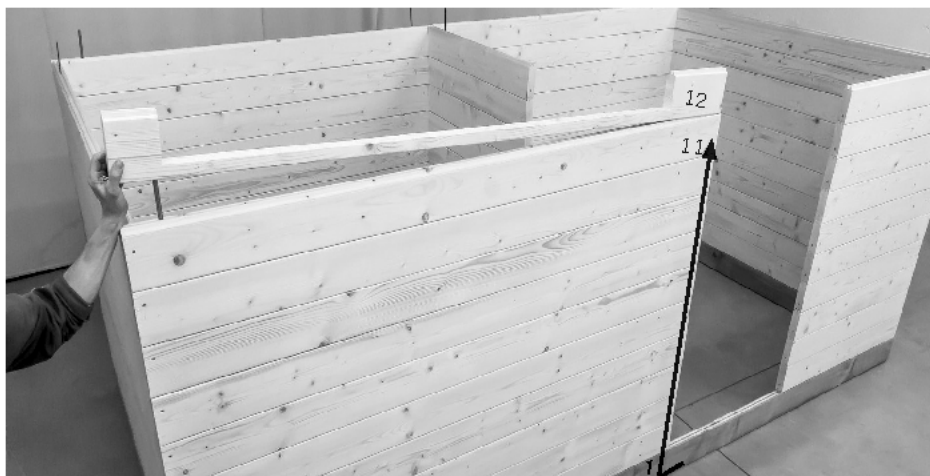

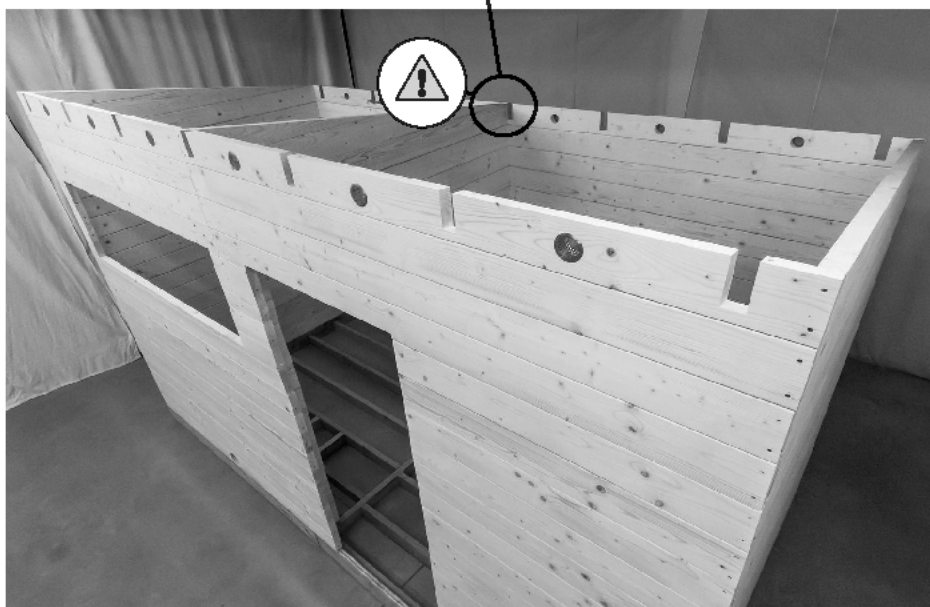
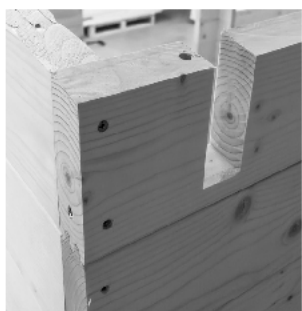
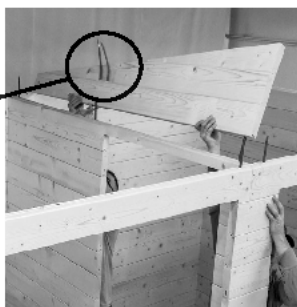

4.4.



4.5.

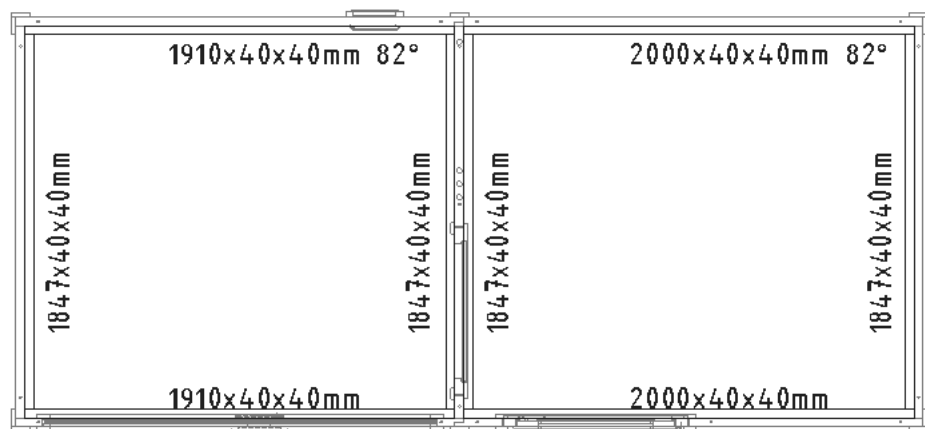
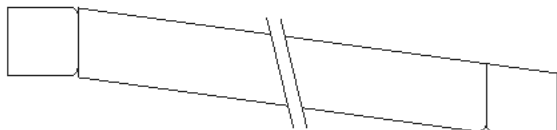



4.6.

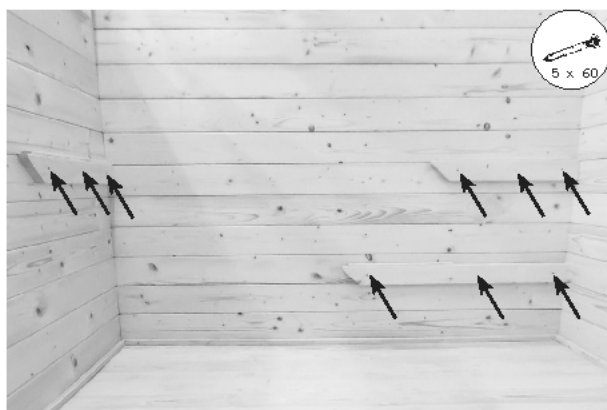
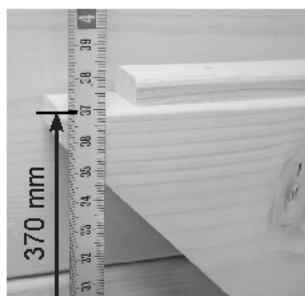
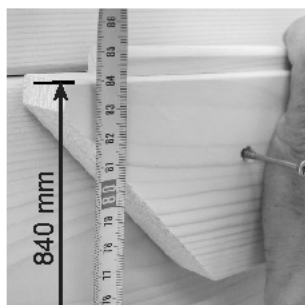



4.7.





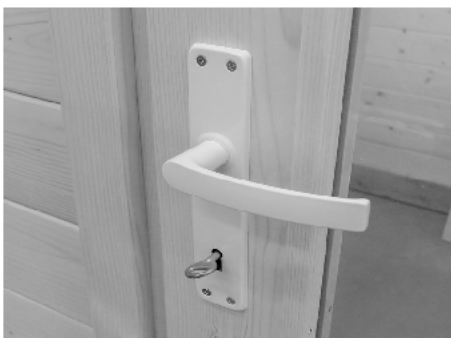

4.8.

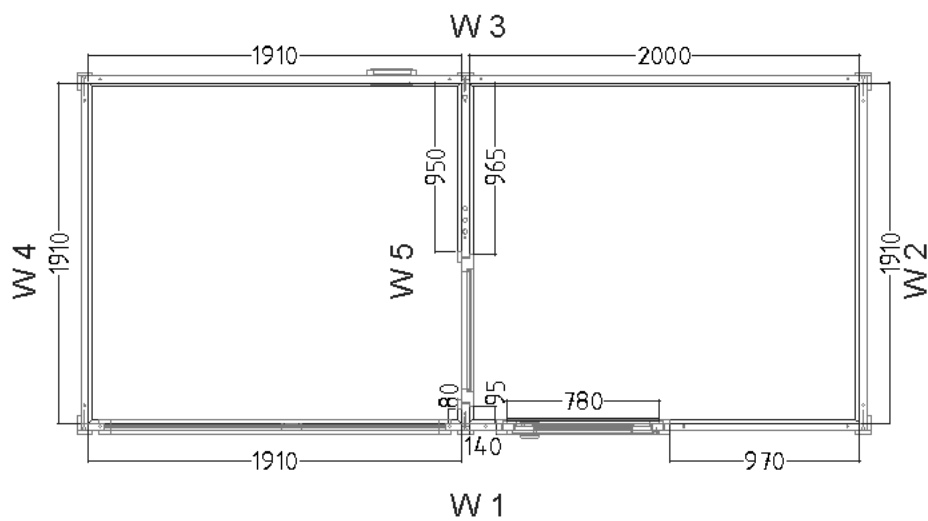

4.9.

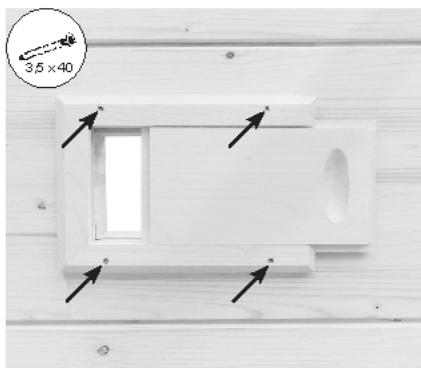

4.10.

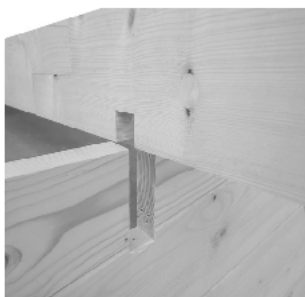
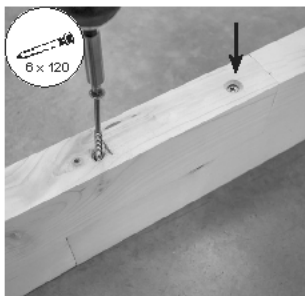
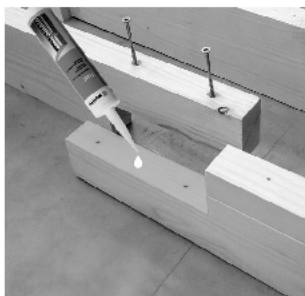

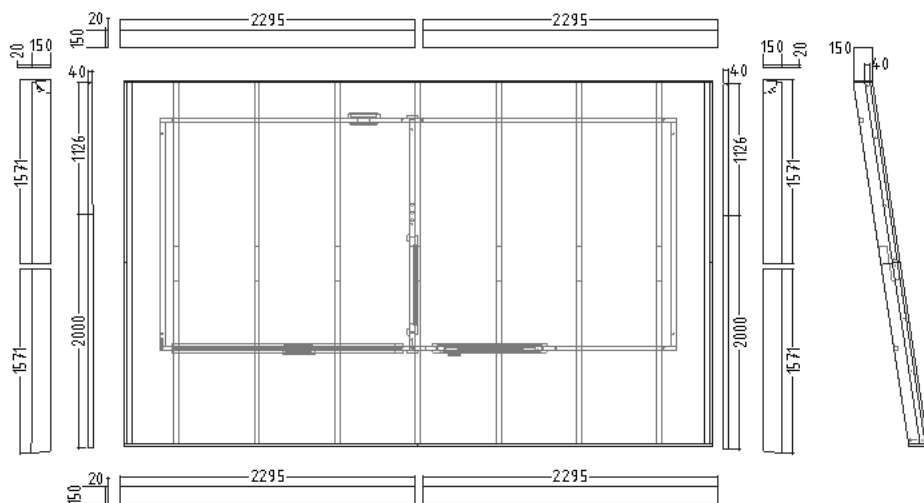

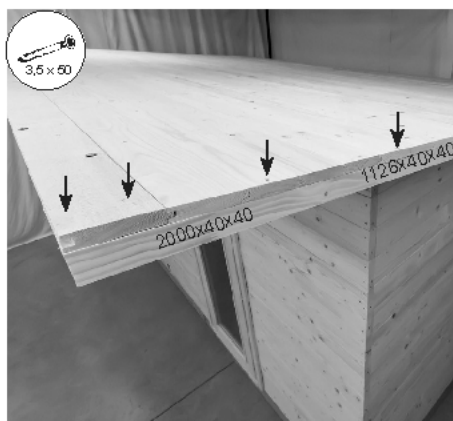

4.11.

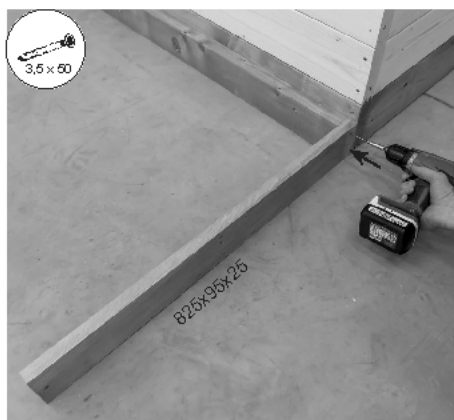
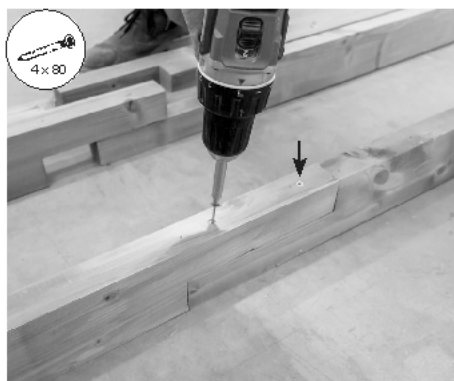
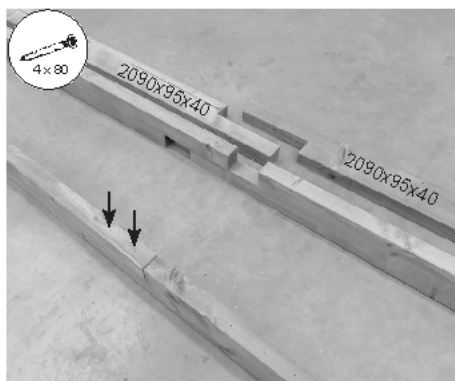

4.12.

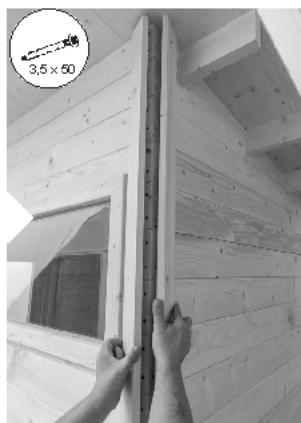

4.13.

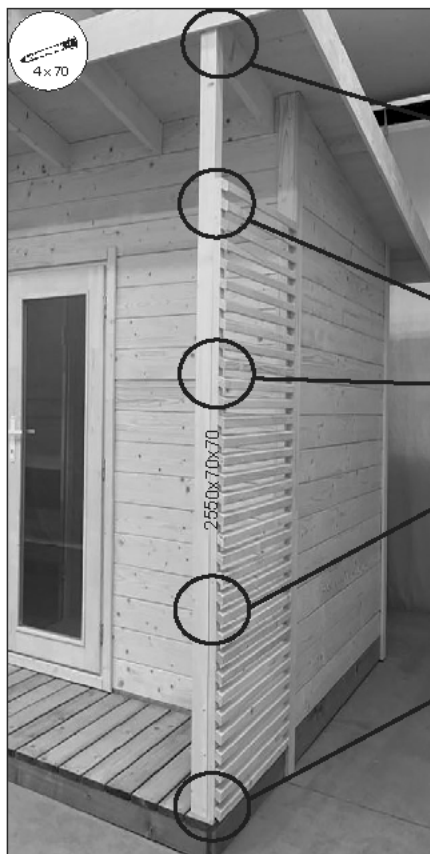

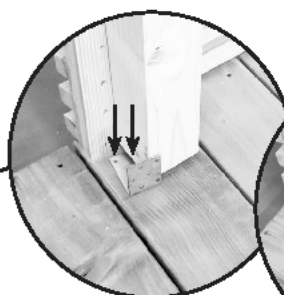
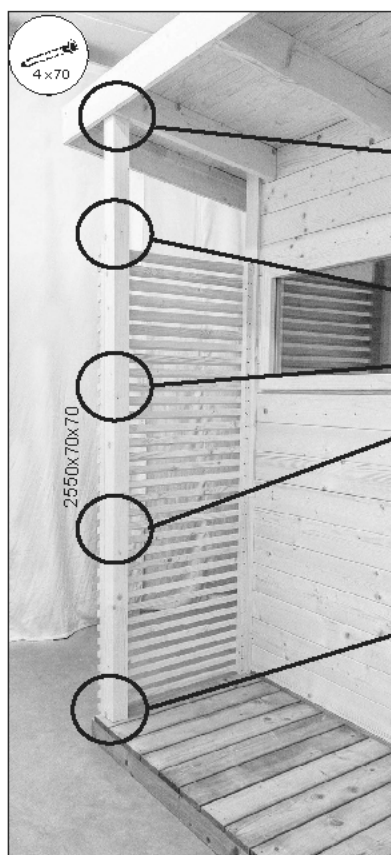



sentiotec GmbH | Division of Harvia Group | Wartenburger Straße 31, A-4840 Vöcklabruck
T +43 (0) 7672/22 900-50 | F -80 | info@sentiotec.com | www.sentiotec.com