



AELIO+HR140

49.9 kW / 50 kW / 60 kW

100kWh~400kWh

User Manual

Version 1.0

www.solaxpower.com



Manual of the C11000 or C110000
http://www.solaxpower.com/

STATEMENT

Copyright

Copyright © SolaX Power Network Technology (Zhejiang) Co., Ltd. All rights reserved.

No part of this manual may be reproduced, transmitted, transcribed, stored in a retrieval system, or translated into any language or computer language, in any form or by any means without the prior written permission of SolaX Power Network Technology (Zhejiang) Co., Ltd.

Trademarks



SOLA_X and other symbol or design (brand name, logo) that distinguishes the products or services offered by SolaX has been trademark protected. Any unauthorized use of the above stated trademark may infringe the trademark right.

Notice

Please note that certain products, features, and services mentioned in this document may not be within the scope of your purchase or usage. Unless otherwise specified in the contract, the contents, information, and recommendations presented in this document are provided "as is" by SolaX. We do not provide any warranties, guarantees, or representations, whether express or implied.

The content of the documents is reviewed and updated as needed. However, occasional discrepancies may occur. SolaX retains the right to make improvements or changes in the product(s) and the program(s) described in this manual at any time without prior notice.

The images included in this document are solely for illustrative purposes and may differ based on the specific product models.

For more detailed information, kindly visit the website of SolaX Power Network Technology (Zhejiang) Co., Ltd. at www.solaxpower.com.

SolaX retains all rights for the final explanation.



Target Group

The installation, maintenance and grid-related setting can only be performed by qualified personnel who:

- Are licensed and/or satisfy state and local jurisdiction regulations.
- Have good knowledge of this manual and other related documents.
- A medium-voltage operator is required to obtain any Certifications for High-voltage Electrician.

Conventions

The symbols that may be found in this manual are defined as follows.

Symbol	Description
 DANGER	Indicates a hazardous situation which, if not avoided, will result in death or serious injury.
 WARNING	Indicates a hazardous situation which, if not avoided, could result in death or serious injury.
 CAUTION!	Indicates a hazardous situation which, if not avoided, could result in minor or moderate injury.
NOTICE!	Provides tips for the optimal operation of the product.

Change History

Version 01 (2025-02-26)

Update "13 Technical Data".

Update "9 Operation on LCD", added ACR Setting and ACR Clear function.

Version 00 (2025-01-08)

Initial release

Table of Contents

1	Safety	1
1.1	General Safety	1
1.2	Safety Instructions of PV, Inverter and Grid	2
1.2.1	Safety Instructions of PV	2
1.2.2	Safety Instructions of Inverter	2
1.2.3	Safety Instructions of Utility Grid	4
1.3	Safety Instructions of Battery	4
2	Product Overview	7
2.1	System Overview	7
2.2	Product Introduction	9
2.3	Supported Power Grid	9
2.4	Appearance and Dimension	11
2.5	Parts Description	12
2.6	Indicator	17
2.7	Symbols on the Label and Inverter	20
2.8	Working State	21
2.9	Working Mode	22
2.9.1	Self-use Mode (Priority: Loads > Battery > Grid)	22
2.9.2	Feed-in Priority (Priority: Loads > Grid > Battery)	24
2.9.3	Backup Mode (Priority: Loads > Battery > Grid)	25
2.9.4	Peak Shaving Mode	26
2.9.5	TOU Mode	28
2.9.6	EPS Mode (Priority: Loads > Battery)	29
2.9.7	Manual Mode	30
2.9.8	Export Control Function	30
2.10	Working Principle	32
2.10.1	Circuit Diagram	32
2.10.2	Application Schemes	33
3	Transportation and Storage	35
3.1	Transportation	35
3.1.1	Inverter Transportation	35
3.1.2	Battery Transportation	35
3.2	Storage	37
3.2.1	Inverter Storage	37

	3.2.2 Battery Storage.....	37
4	Preparation before Installation.....	39
	4.1 Installation Options.....	39
	4.2 Selection of Installation Location.....	42
	4.2.1 Installation Carrier Requirement.....	45
	4.2.2 Clearance Requirement.....	46
	4.3 Tools Requirement.....	48
	4.4 Additionally Required Materials.....	50
5	Unpacking and Inspection.....	52
	5.1 Battery Unpacking.....	52
	5.1.1 Unpacking.....	52
	5.1.2 Scope of Delivery.....	53
	5.2 Inverter Unpacking.....	58
	5.2.1 Unpacking.....	58
	5.2.2 Scope of Delivery.....	59
6	Mechanical Installation.....	61
	6.1 Screws and Torques.....	62
	6.2 One bracket Battery System Installation.....	64
	6.3 Dual bracket Battery System Installation.....	74
	6.4 Inverter Installation.....	86
	6.4.1 Installation Dimensions.....	87
	6.5 Installation Procedures.....	88
	6.5.1 Wall Mounting Procedures.....	88
7	Electrical Connection.....	93
	7.1 One bracket Battery System Wiring.....	93
	7.1.1 PE Connection.....	95
	7.1.2 Fan Power Cable Connection.....	96
	7.1.3 Communication Connection.....	98
	7.1.4 Copper Bar Connection.....	100
	7.1.5 Power Cable Connection.....	103
	7.2 Dual bracket Battery System Connection.....	107
	7.2.1 PE Connection.....	109
	7.2.2 Fan Power Cable Connection.....	110
	7.2.3 Communication Connection.....	112
	7.2.4 Copper Bar Connection.....	115
	7.2.5 Power Cable Connection.....	119
	7.3 Inverter Wiring.....	124

7.3.1	Terminals of Inverter.....	124
7.3.2	PE Connection.....	125
7.3.3	AC Connection.....	128
7.3.4	PV Connection.....	137
7.3.5	Battery Power Cable Connection.....	142
7.3.6	COM 1 Communication Connection.....	147
7.3.7	COM 2 Communication Connection.....	156
7.3.8	Monitoring Connection.....	165
8	System Commissioning	168
8.1	Checking before Power-on.....	168
8.2	Powering on the System.....	168
8.3	Checking after Powering on	170
8.4	Operation of Lockable DC Switch (for Australia Version Only).....	171
9	Operation on LCD.....	174
9.1	Introduction of Control Panel.....	174
9.2	Introduction of Menu Interface.....	175
9.3	System ON/OFF.....	177
9.4	Mode Select.....	177
9.5	System Status.....	177
9.6	Parallel Status.....	179
9.7	History Data.....	179
9.8	Setting.....	182
9.8.1	User Setting.....	182
9.8.2	Advance Setting.....	190
9.9	About.....	208
9.10	Inverter screen cover installation.....	209
10	SolaXCloud App.....	210
10.1	Introduction of SolaXCloud.....	210
10.2	Operation Guide on SolaXCloud App.....	210
10.2.1	Downloading and Installing App.....	210
10.2.2	Operation on the SolaXCloud App.....	211
11	Troubleshooting and Maintenance	212
11.1	Power off.....	212
11.2	Troubleshooting.....	213
11.3	Maintenance.....	224
11.3.1	Maintenance Routines	224
12	Decommissioning.....	225

12.1 Disposing of the Wasted and Damaged Battery Pack	225
12.2 Disposing of the Wasted and Damaged Inverter	225
13 Technical Data	226
14 Appendix	233
14.1 Micro-grid Application	233
14.1.1 Introduction of Micro-grid Application.....	233
14.1.2 Wiring Connection Diagram.....	233
14.1.3 Working Modes.....	234
14.1.4 Cable Connection (Hybrid inverter).....	236
14.1.5 Cable Connection (On-grid Inverter).....	236
14.1.6 Cable Connection (Meter).....	236
14.2 CT/Meter Connection Scenarios	239
14.2.1 Connection of CT.....	239
14.2.2 Connection of Direct-connected Meter	242
14.2.3 Connection of CT-connected Meter	245
14.2.4 Connection of Two Meters	248
14.3 Capacity Expansion.....	253

1 Safety

1.1 General Safety

The series device has been meticulously designed and thoroughly tested to comply with all relevant state and international safety standards. Nevertheless, like all electrical and electronic equipment, safety precautions must be observed and followed during the installation of the device to minimize the risk of personal injury and ensure a safe installation.

Please thoroughly read, comprehend, and strictly adhere to the comprehensive instructions provided in the user manual and any other relevant regulations prior to the installation of the device. The safety instructions in this document serve as supplementary guidelines to local laws and regulations.

SolaX shall not be liable for any consequences resulting from the violation of the storage, transportation, installation, and operation regulations outlined in this document. Such consequences include, but are not limited to:

- Device damage caused by force majeure events, such as earthquakes, floods, thunderstorms, lightning, fire hazards, volcanic eruptions, and similar events.
- Device damage due to human causes.
- Device damage caused by strong vibrations from external factors before, during and after installation.
- Usage or operation of the device in violation of local policies or regulations.
- Failure to comply with the operation instructions and safety precautions provided with the product and in this document.
- Improper installation or usage of the device in unsuitable environmental or electrical conditions.
- Unauthorized modifications to the product or software.
- Device damage occurring during transportation by the customer.
- Storage conditions that do not meet the requirements specified in this document.
- Failure to adequately maintain the device.
- Installation and commissioning performed by unauthorized personnel who lack the necessary licenses or do not comply with state and local jurisdiction regulations.

1.2 Safety Instructions of PV, Inverter and Grid

Save these important safety instructions. Failure to do so may result in damage to the inverter and injury or even loss of life.

1.2.1 Safety Instructions of PV



Potential risk of lethal electrical shock associated with the photovoltaic (PV) system

- Exposure to sunlight can result in the generation of high DC voltage by PV modules, which can lead to electric shock causing severe injuries or even death.
- Never touch the positive or negative poles of the PV connecting device, and avoid touching both poles simultaneously.
- Do not ground the positive or negative poles of the PV modules.
- Only qualified personnel can perform the wiring of the PV modules.



- Overvoltage protection with surge arresters should be provided when the PV system is installed. The grid connected inverter is fitted with SPDs on both PV input side and MAINS side.
- Please consult professionals before installing SPDs.



- Make sure that the input DC voltage does not exceed the maximum DC input voltage specified for the inverter. Overvoltage can cause irreversible damage to the inverter, and such damage is not covered by the warranty.
- PV modules should have an IEC61730 class A rating.

1.2.2 Safety Instructions of Inverter



Potential risk of lethal electrical shock associated with the inverter

- Only operate the inverter if it is in a technically faultless condition. Operating a faulty inverter may lead to electric shock or fire.
- Do not attempt to open the enclosure without authorization from SolaX. Unauthorized opening of the enclosure will void the warranty and can result in lethal danger or serious injury due to electric shock.
- Make sure that the inverter is reliably grounded before any operation to prevent the risk of electric shock causing lethal danger or serious injury.
- Only qualified personnel can perform the installation, wiring, maintenance of the inverter by following this document and the related regulations.

 DANGER!

- Prior to any wiring connection, establishing an earth connection is essential.

 WARNING!

- During operation, avoid touching any parts of the inverter other than the DC switch and LCD panel.
- Never connect or disconnect the AC and DC connector while the inverter is running.
- Prior to conducting any maintenance, turn off the AC and DC power and disconnect them from the inverter. Wait for 5 minutes to fully discharge the energy.

 WARNING!**Potential danger of scalding due to the hot enclosure of the inverter**

- Avoid touching the inverter while it is running, as it becomes hot during operation and may cause personal injuries.

 WARNING!

- When handling the battery, carefully follow all safety instructions provided in the battery manual. The battery used with the inverter must meet the specified requirements of the series inverter.

 CAUTION!

- Make sure that children are supervised to prevent them from playing with the inverter.
- Pay attention to the weight of the inverter and handle it properly to avoid personal injuries.
- Use insulated tools when installing the device, and always wear personal protective equipment during installation and maintenance.

NOTICE!

- The inverter has an integrated Type-B Residual Current Monitoring Unit (RCMU). If an external Residual Current Device (RCD) is required by local regulations, verify the type of RCD required. It is recommended to use a Type-A RCD with a rating of 300 mA unless a lower value is required by the specific local electric codes. When required by local regulations, the use of an RCD type B is permitted.
- Keep all product labels and the nameplate on the inverter clearly visible and well-maintained.

1.2.3 Safety Instructions of Utility Grid

NOTICE!

- Only connect the inverter to the grid with the permission of the local utility grid company.

1.3 Safety Instructions of Battery

General safety precautions

- Overvoltage or wrong wiring may damage the battery pack and cause combustion which may be extremely dangerous;
- Leakage of electrolytes or flammable gas may be occurred due to any type of product breakdown;
- Do not install the battery pack in places where flammable and combustible materials are stored, and in which an explosive atmosphere is present;
- The battery pack wiring must be carried out by qualified personnel;
- Battery pack must be serviced by qualified personal;
- Ensure that the grounding cable is connected before handling the battery pack.

Battery handling guide

Do's

- DO keep the battery pack away from flammables materials, heat sources, and water sources;
- DO keep the battery pack out of reach of children and animals;
- DO practice proper battery storage by keeping the battery pack in a clean environment, free of dust, dirt and debris;
- DO store the battery pack in a cool and dry place;
- DO seal the outer cable connection hole to prevent ingress of foreign objects;
- DO confirm that the wiring of the device must be correct;
- DO install the device according to the local standards and regulations.

Don'ts

- DON'T expose the battery pack to an open flame, or the temperature in excess of

140°F/60°C;

- DON'T install or operate the battery pack in places where there is excessive moisture or liquids;
- DON'T place the battery pack in a high-voltage environment;
- DON'T disconnect, disassemble or repair the device by unqualified personnel. Only a qualified personnel is allowed to handle, install and repair the device;
- DON'T damage the device by dropping, deforming, impacting, cutting or penetrating with a sharp object. Otherwise, it may cause a fire or leakage of electrolytes;
- DON'T touch the device if liquid spill on it. There is a risk of electric shock;
- DON'T step on the packaging or the device may be damaged;
- DON'T place any objects on top of the battery pack;
- DON'T charge or discharge a damaged battery pack;
- DON'T dispose of the battery pack in a fire. It may cause leakage or rupture;
- DON'T mix different types or makes of the battery pack. It may cause leakage or rupture, resulting in personal injury or property damage.

Response to emergency situations

In case the battery module leaks electrolyte or any other chemical materials, or gas may be generated due to the leakage of battery module, be sure to avoid contact with the discharge at all times. In case of accidentally coming into contact with them, please do as follows:

- In case of inhalation: Leave the contaminated area immediately, and seek medical attention at once;
- In case of contact with eyes: Rinse eyes with running water for 15 minutes, and seek medical attention;
- In case of contact with skin: Wash the contacted area thoroughly with soap, and seek medical attention;
- In case of ingestion: Induce vomiting, and seek medical attention.

If a fire breaks out where the battery module is installed, please do as follows:

- In case the battery pack is charging when the fire breaks out, provide it is safe to do so, disconnect the battery pack circuit break to shut off the power charge;
- In case the device is not on fire yet, use a Class ABC fire extinguisher or a carbon dioxide extinguisher to extinguish the fire;
- If the battery pack catches fire, do not try to put out the fire, and evacuate immediately.
- The battery pack may catch fire when it is heated above 302°F/150°C; and in case

of catching fire, it will produce noxious and poisonous gas, DO not approach and keep away.

Effective ways to deal with accidents

- In case of the damaged battery pack, place it into a segregated place, and call the local fire department at the place where the user lives or qualified personnel.
- If any part of the battery pack, or wiring is submerged, DO stay out of the water and DON'T touch anything; If the battery pack gets wet, DON'T touch it.
- If the battery pack is damaged, DON'T use it. Otherwise, it may result in both personal injury and property damage.
- DON'T use the submerged battery pack again, and contact the qualified personnel for assistance.
- DO contact SolaX immediately for assistance if the user suspects that the battery pack is damaged.

 WARNING!

- Do not crush or impact battery, and always dispose of it according to relevant safety regulations.
- The battery pack may catch fire when heated above 150°C/302°F.
- In case of catching fire, the battery pack will produce noxious and poisonous gases, and please keep away the battery.
- Damaged batteries may leak electrolyte or produce flammable gas. If users suspect that the battery is damaged, please immediately contact SolaX for advice and information.
- All operations of the batteries relating to electrical connection and installation must be carried out by qualified personnel.

 CAUTION!

- If the battery pack is not installed within a month after receipt, it must be charged for maintenance. Non-operational batteries should be discarded according to the local regulations.

2 Product Overview

2.1 System Overview

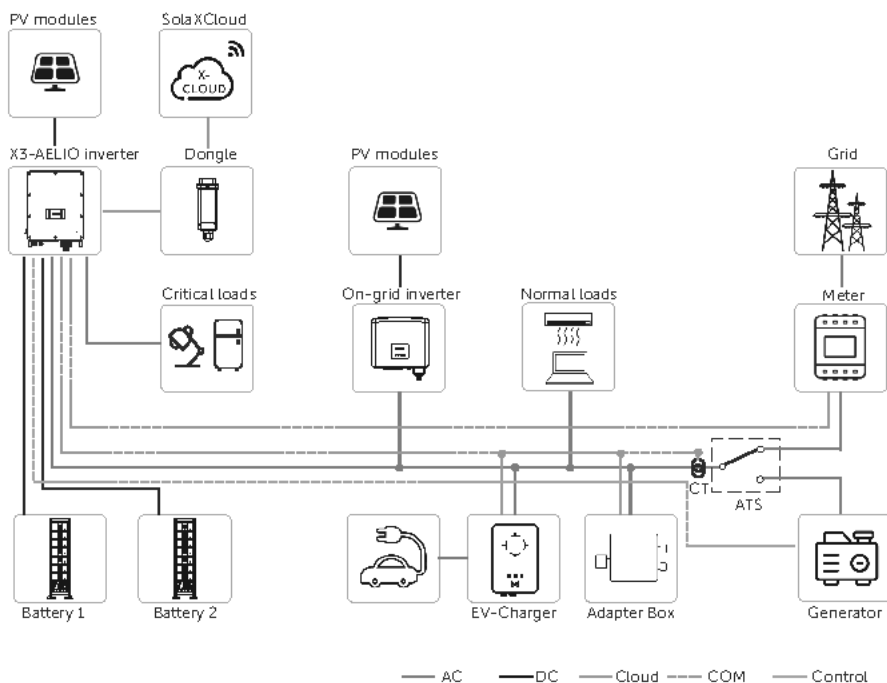

Figure 2-1 System overview diagram

NOTICE!

- The battery system configuration in this section takes T-HR100.1 as an example, for specific configuration options, please refer to "4.1 Installation Options".
- Please be aware that some devices cannot be worked simultaneously.

Table 2-1 System item description

Item	Description
X3-AELIO series inverter	The X3-AELIO series inverter manages battery and system energy.
PV modules	PV modules work in MPPT mode. The maximum number of PV MPP tracker is five for 50 kW inverter and six for 60 kW inverter.
Battery	The TSYS-HR143 battery system consists of a high-voltage box, battery packs with integrated 280Ah high-capacity cells, and an intelligent air-cooling system as a reserve energy source.
CT/Meter	The CT/meter is used by the inverter for import / export or consumption readings, and manages the battery charge / discharge accordingly for smart energy management applications.
Additional on-grid inverter (supported)	The inverter supports micro-grid function that makes hybrid inverter simulate the grid to active on-grid inverter during off-grid period by connecting on-grid inverter to hybrid inverter's EPS terminal. Please refer to "14.4 Micro-grid Application" for specific wiring and setting. The nominal power of the on-grid inverter should be no more than that of the EPS terminal of X3-AELIO inverter.
Adapter Box (optional)	With SolaX Adapter Box, you can connect the smart heat pump to the energy storage systems, realizing the control of the heat pump through inverter.
EV-Charger (optional)	The inverter can communicate with SolaX EV-Charger to form an intelligent photovoltaic, storage and EV charging energy system, thus maximizing the utilization of photovoltaic energy.
Generator (optional)	SolaX PV-Genset solution ensures optimum interaction between the photovoltaics and diesel generator, which saves fuel, lowers energy costs and ensures a stable and reliable power supply.
Grid	400 V / 230 V and 380 / 220 V grid are supported. Power grid TT, TN-S, TN-C-S can be supported.
SolaXCloud	SolaXCloud is an intelligent, multifunctional monitoring platform that can be accessed either remotely or through a hard wired connection. With the SolaXCloud, the operators and installers can always view key and up-to-date data. There are two SolaXCloud platforms. Commercial platform can be connected through EMS1000 connection.

2.2 Product Introduction

The product "AELIO+HR140" is an energy storage system that is both powerful and highly scalable. It meets the capacity requirements of single systems from 100.1 kWh to 400.4 kWh, is equipped with a high-voltage box for optimal performance and protection, and maximises energy efficiency, and supports indoor and outdoor installations, as well as bracket-mounted and stacked installations.

Safety and reliability with the X3-AELIO inverter: Supports up to 200% PV overcapacity, 100% three-phase imbalance, 110% long term overload, 10 ms on/off switching, 150% off-grid overload. With its intelligent design, flexible configuration options and wide operating temperature range, the system is suitable for a variety of applications.

2.3 Supported Power Grid

There are different ways of wiring for different grid systems. TT / TN-S / TN-C-S are shown below:

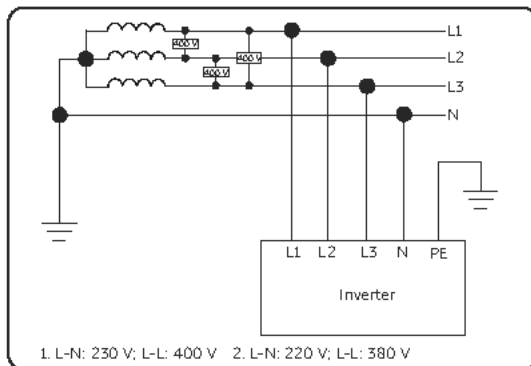

Figure 2-2 Supported power grid-TT

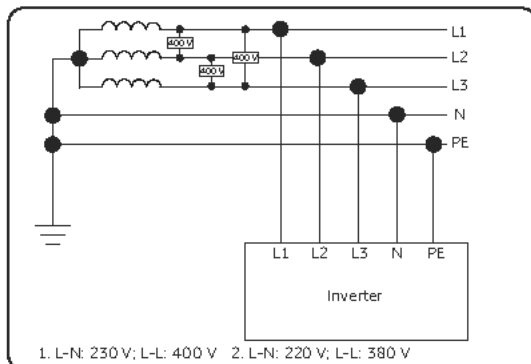

Figure 2-3 Supported power grid-TN-S

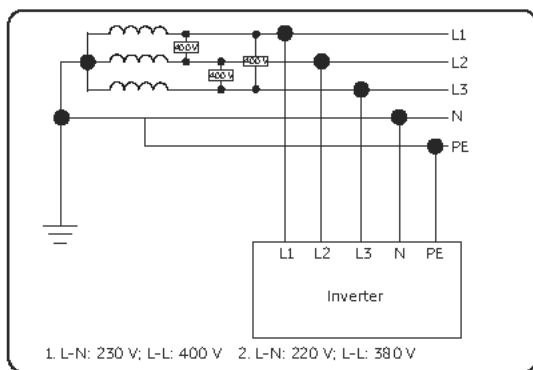

Figure 2-4 Supported power grid-TN-C-S

NOTICE!

- If a different power grid is required, please consult our SolaX after-sales team for confirmation.

2.4 Appearance and Dimension

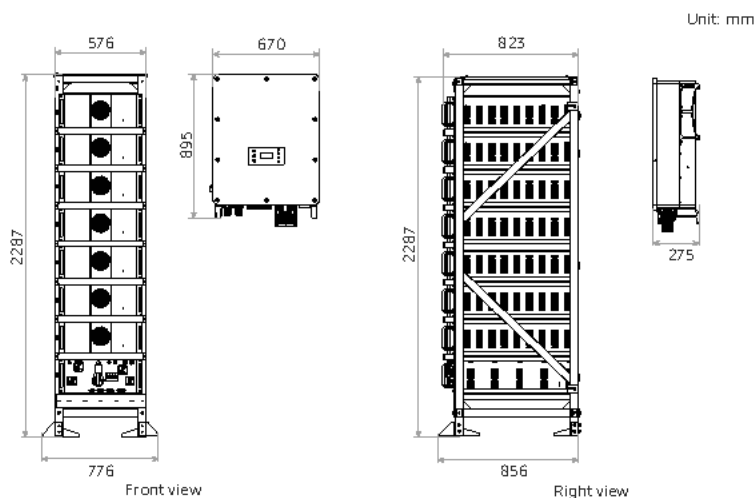

Figure 2-5 One bracket system

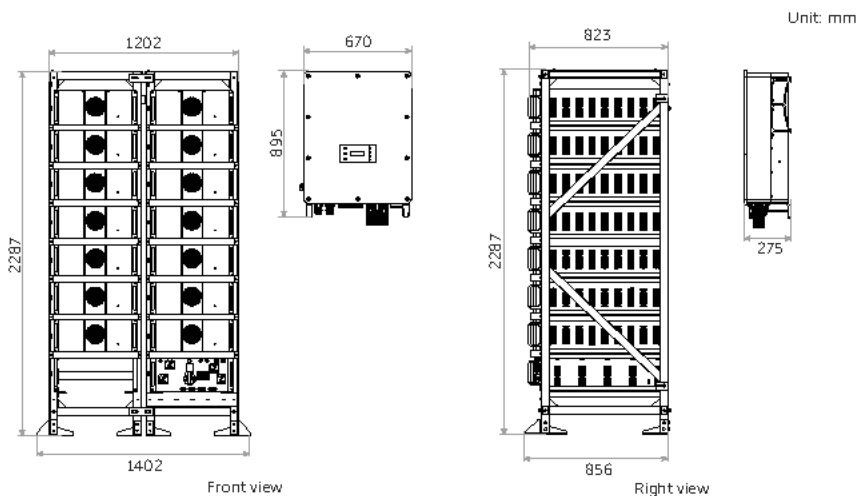

Figure 2-6 Dual bracket system

NOTICE!

- The battery system configuration of dual bracket system takes T-HR200.2 as an example, for specific configuration options, please refer to "4.1 Installation Options".

2.5 Parts Description

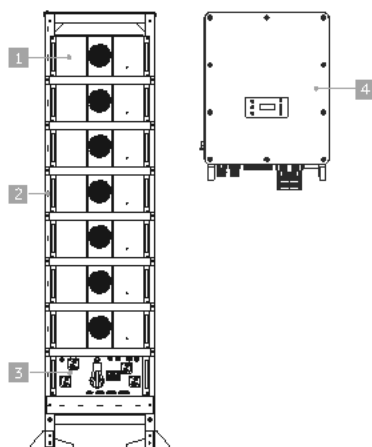

Figure 2-7 Product overview

Table 2-2 System description

No.	Item	Description
1	Battery pack	A type of electrical battery which can charge loads.
2	Bracket	To place and secure battery pack(s) and high-voltage box.
3	High-voltage box	To collect current and voltage information on battery cluster, and control the charge and discharge of battery pack.
4	Inverter	To manage battery and system energy.

Inverter

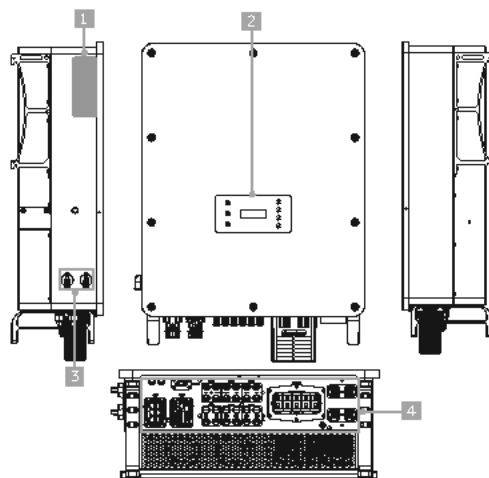

Figure 2-8 Parts description

Table 2-3 Parts description

No.	Item	Description
1	Type label	Type label clearly identifies the device type, serial number, specific DC / AC parameters, certification, etc.
2	LCD panel	Including screen, indicators and keys. Screen displays the information; indicators indicate the status of inverter. Keys are used to perform the parameter setting.
3	DC switch	Disconnect the PV DC input when necessary. DC switch 1 controls MPPT 1, 2 and 3, DC switch 2 controls MPPT 4, 5 and 6.
4	Electrical connection area	Including PV terminals, battery terminals, Grid and EPS terminals, communication terminals, etc.

High-voltage box

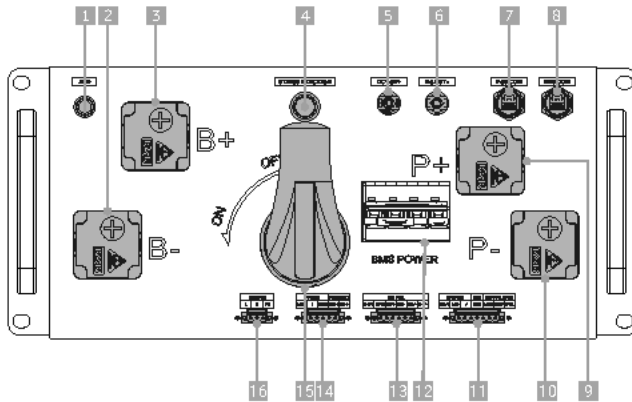

Figure 2-9 Front panel of high-voltage box

Table 2-4 Description of front panel

No.	Item	Description
1	ADD button	To assign address.
2	Negative output port	To connect battery pack's negative terminal.
3	Positive output port	To connect battery pack's positive terminal.
4	Status indicator	To show operating status.
5	DC output +	Reserved
6	DC output -	Reserved
7	Communication port (for inverter)	To connect inverter's communication port.
8	Communication port (for EMS)	To connect EMS's communication port.
9	P+ port	To connect inverter's positive terminal.
10	P- port	To connect inverter's negative terminal.
11	Terminal block (for battery pack)	To connect battery pack's communication cable and power cable.
12	Breaker	/
13	Terminal block (for fan)	To connect fan's power cable.
14	Communication terminal block (for IO module)	To connect the IO module's CAN port and dry contact of the inverter

No.	Item	Description
15	Disconnect switch	To disconnect the device on the DC side.
16	AC input (for fan)	To connect to the grid.

Battery pack

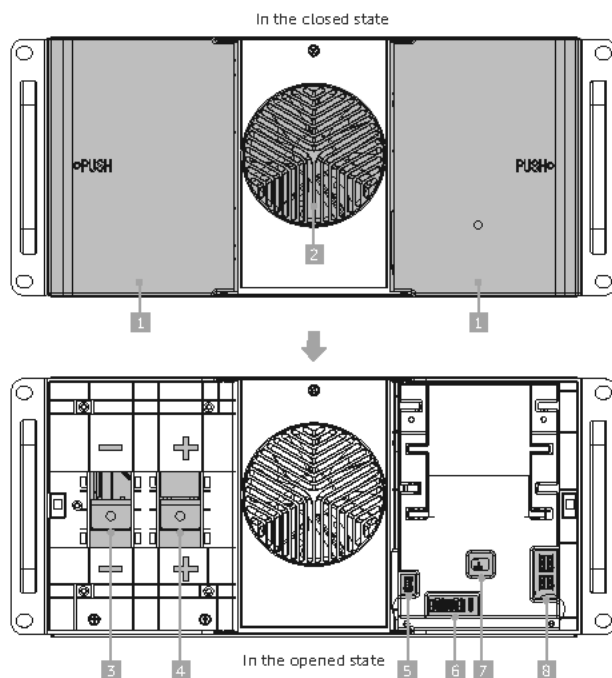

Figure 2-10 Front panel of battery pack

Table 2-5 Description of front panel

No.	Item	Description
1	Left/right cover	Please open the cover while wiring.
2	Fan	To keep components cool in the battery pack.
3	Negative terminal	To connect negative terminal of high-voltage box or battery pack.
4	Positive terminal	To connect positive terminal of high-voltage box or battery pack.

No.	Item	Description
5	Cable connection port (for fan)	To connect the fan.
6	Power connector (for fan)	To provide power to the fan.
7	BMS's status light	To display the running status of BMS.
8	Communication port	To connect communication cable of high-voltage box or the next battery pack.

Bracket

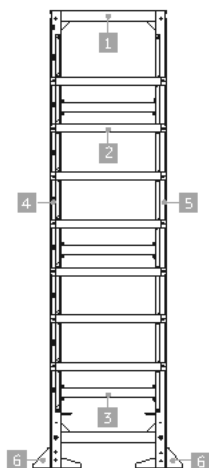

Figure 2-11 Appearance of bracket

Table 2-6 Description of bracket

No.	Item	Description
1	Bracing	To connect and secure the upper and lower parts of the left frame and right frame of bracket.
2	Protection bar	/
3	Beam	To connect and secure the middle parts of the left frame and right frame of bracket.
4	Left frame	/
5	Right frame	/
6	Angle support	To secure the bottom of bracket.

2.6 Indicator

Inverter LED panel

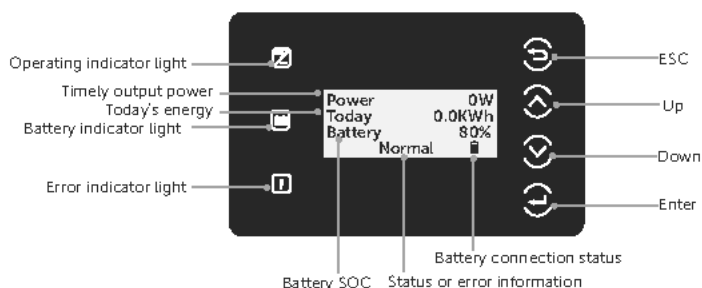













Figure 2-12 LED panel

Table 2-7 Description

LED indicator	Status	Definition
 Operating	 Solid blue	The inverter is in a normal state.
	 Blue blinking	The inverter is in a waiting or checking state.
 Error	 Solid red	The inverter is in a fault state.
	 Green blinking	Both of the batteries are in an idle state.
 Battery	 Solid green	Either of the battery is in normal state.
	 Green blinking	Both of the batteries are in an idle state.
 /	 Solid display	Either of the battery is connected normally.
	 Blinking	Both of the batteries are disconnected.

High-voltage box

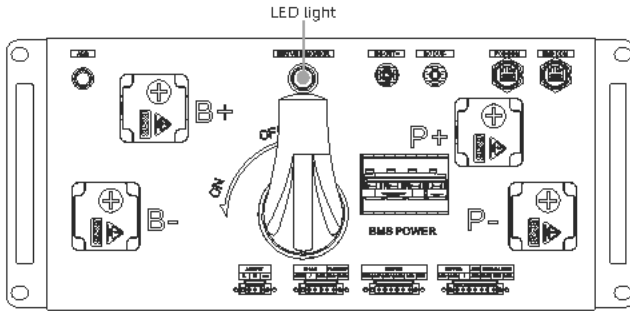







Figure 2-13 High-voltage box LED light

Table 2-8 Description

Status	Definition
	Solid green Start up ¹
	Solid green Standby
	Green blinking Charging ²
	Green blinking Discharging ³
/	Off Shut down
	Solid red Fault
	Solid green → Green blinking Black Start

NOTICE!

- ¹ The battery system will assign each battery pack in a communication loop a unique address (battery number) during the "Start up" state. In the meantime, the LED light flashes green fast every 0.1 seconds.
- ² When the device is in the "Charging" state, the LED light flashes green every 0.85 seconds.
- ³ When the device is in the "Discharging" state, the LED light turns on green for 2 seconds and off for 0.85 seconds.

Black start

The equipment can provide **Black Start** capacity, meaning that our energy storage inverter and battery can continue to run even if the power grid and photovoltaic panel are out of service. The startup procedure for **Black Start** is as follows:

- Press the "ADD" button 3 times, with every press within 2 seconds, to activate Black Start. Meanwhile, the status light turns green blinking from solid green.

NOTICE!

- If the interval between every two presses is over 2 seconds, the button needs to be re-pressed 3 times.

Battery pack

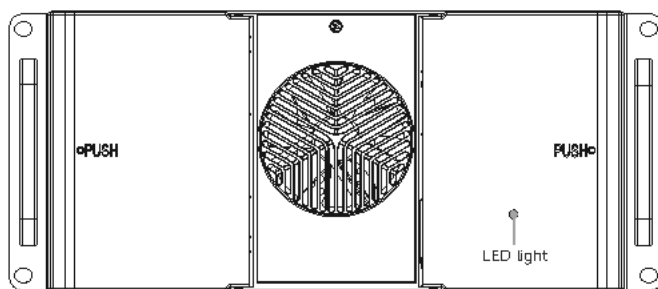



















Figure 2-14 Battery pack light



Table 2-9 Description

Status	Definition
 Green slow blinking	In normal operation
 Green blinking	CAN communication loss for 300 seconds
 Solid red	CAN communication loss for 30 seconds
 Yellow slow blinking	AFE communication loss
 Red slow blinking	Disconnection of battery cell's voltage sampling cable

2.7 Symbols on the Label and Inverter

Table 2-10 Description of symbols

Symbol	Description
	CE mark. The inverter complies with the requirements of the applicable CE guidelines.
	TUV certified.
	RCM mark. The inverter complies with the requirements of the applicable RCM guidelines.
	The battery system must be disposed of at a proper facility for environmentally-safe recycling.
	Additional grounding point
	The battery pack may explode. The rechargeable battery can become hot during operation. Avoid contact during operation.
	Beware of hot surface. Do not touch a running inverter, as the inverter becomes hot during operation!
	Risk of electric shock. High voltage exists after the device is powered on!
	Risk of danger Potential hazards exist after the device is powered on!
	Observe enclosed document.
	The device can not be disposed together with the household waste.
	Do not operate this inverter until it is isolated from battery, mains and on-site PV generation source.
	Keep the battery system away from children.

Symbol	Description
	Keep the battery system away from open flames or ignition sources.
 	Danger to life due to high voltage. Residual voltage exists after the inverter is powered off, which needs 5 minutes to fully discharge. Wait 5 minutes before attempting any service.

2.8 Working State

The series inverter has Waiting, Checking, Normal, EPS Checking, EPS, Fault, Idle and Standby state.

Table 2-11 Description of working state

State	Description
Waiting	The inverter is waiting for the conditions to be met in order to enter the Checking state.
Checking	<ul style="list-style-type: none"> The inverter is checking for conditions to enter Normal state.
Normal	<ul style="list-style-type: none"> The inverter is working normally.
EPS Checking	<ul style="list-style-type: none"> The inverter is checking for conditions to enter EPS state.
EPS	<ul style="list-style-type: none"> The inverter is working in off-grd state.
Fault	<ul style="list-style-type: none"> The inverter detects error occurred and prompts error code.
Idle	<ul style="list-style-type: none"> A standby state when the the battery SOC reaches the minimum SOC and there is no sufficient PV input voltage.
Standby	<ul style="list-style-type: none"> A standby state when the power of load is extremely low and there is no sufficient PV input voltage, or a state when the battery SOC is less than or equal to 10% and there is no sufficient PV input voltage. In this state, it detects PV connection, load power, battery forced charged, etc to determine whether to exit Standby state and enter Normal state.

NOTICE!

- When the inverter is in an Idle state, you can reset the work mode, the Min SOC and the charging periods through the inverter LCD or the SolaX APP to charge the battery to the Min SOC in the charging periods and then awaken the inverter. Please make sure that the actual battery SOC - the modified Min SOC \geq 2% under a specific work mode, so that other modifications are effective. When the current system time is within the new charging periods you reset, the battery begins charging.

2.9 Working Mode

Six working modes are available for use to choose in on-grid status, i.e Self use, Feed-in priority, Backup, Peak shaving, Schedule and Manual. You can choose the working modes according to your lifestyle and environment.

When the power supply from the electric power company is stopped due to a power outage, it automatically switches to EPS mode and connects to the distribution board for a specific load, thereby providing power to important electrical appliances.

For how to set the working mode, please refer to the section "9.8.1 User Setting".

2.9.1 Self-use Mode (Priority: Loads > Battery > Grid)

The self-use mode is suitable for areas with low feed-in subsidies and high electricity prices. The power of PV will supply the loads first, and the surplus power will charge the battery, then the remaining power will feed into the grid.

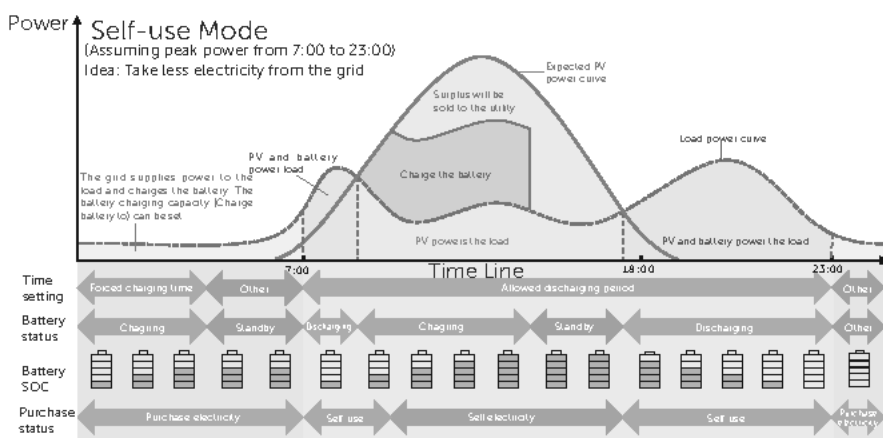

Figure 2-15 Self-use mode

Table 2-12 Description of self-use mode

Time period	Inverter working status
Forced charging period	<ul style="list-style-type: none"> Charge the battery firstly until the battery SOC reaches the specified Charge battery to value. You can configure the inverter to either draw power from the grid or not.

Time period	Inverter working status
Allowed discharging period	PV is sufficient (PV → load → battery → grid) <ul style="list-style-type: none"> The power generated from PV prioritizes supplying the load. Any excess power is then directed towards charging the battery, and if there is still surplus electricity, it can be sold to the grid. In the event that the local utility restricts the sale of electricity to the grid, the export control value can be set on the inverter.
	PV is insufficient (PV+battery → load) <ul style="list-style-type: none"> The battery discharges power to the load, and once its capacity reaches Min SOC, it automatically ceases discharging.

Note:

Charge battery to: The battery SOC charged from grid. 10% by default, the settable range is 10%~100%.

Min SOC: Minimum SOC of the battery under grid connection. 10% by default, the settable range is 10%~100%.

Charge & Discharge period

You can set two configurable working periods: forced charging period and allowed discharging period. The interval not in the charging & discharging period belongs to other time periods.

- Forced charging period (Default period: 00:00~00:00, closed by default)

The priority of forced charging period is higher than all working modes. In the forced charging period, the inverter will charge the battery first until the battery SOC reaches the specified **Charge battery to** value set in each working mode. You have the option to configure the inverter to either draw power from the grid or not.

- Allowed discharging period (Default period: 00:00~23:59)

In the allowed discharging period, the inverter will allow the battery to discharge and charge power in accordance with the working mode and load conditions.

- Period not set as forced charging or allowed discharging period

In this period, the inverter will allow the battery to charge but can not discharge power.

NOTICE!

- The charging and discharging period is only applicable for self-use mode, feed-in priority and backup mode.

2.9.2 Feed-in Priority (Priority: Loads > Grid > Battery)

The feed-in priority mode is suitable for areas with high feed-in subsidies, but has feed-in power limitation. The power generated from PV is directed towards supplying the loads. Any excess power beyond the load requirements will be fed into the grid.

Note: If the amount of electricity sold to the grid is limited, the remaining power will be utilized to charge the battery.

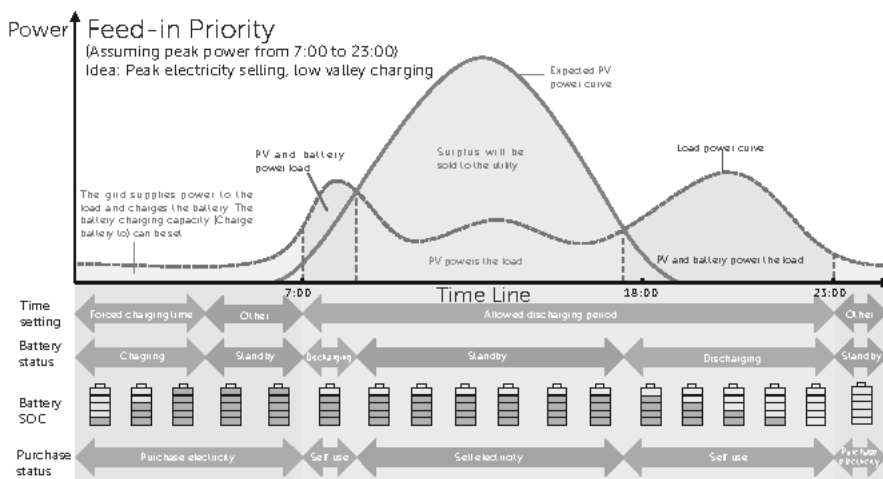

Figure 2-16 Feed-in priority

Table 2-13 Description of feed-in priority

Time period	Inverter working status
Forced charging period	<ul style="list-style-type: none"> Charge the battery firstly until the battery SOC reaches the specified Charge battery to value. You can configure the inverter to either draw power from the grid or not.
Allowed discharging period	PV is sufficient (PV → load → grid)
	<ul style="list-style-type: none"> The power generated from PV is directed towards supplying the loads. Any excess power beyond the load requirements will be fed into the grid,
	PV is insufficient (PV+battery → load)
	<ul style="list-style-type: none"> PV and battery supply power to the load at the same time, and once the battery capacity reaches Min SOC, it automatically ceases discharging.

Note:

Charge battery to: The battery SOC charged from grid. 50% by default, the settable range is 10%~100%.

Min SOC: Minimum SOC of the battery under grid connection. 10% by default, the settable range is 10%~100%.

NOTICE!

- You can set two configurable working periods: forced charging period and allowed discharging period in feed-in priority mode. Please refer to "Charge & Discharge Period" for details.

2.9.3 Backup Mode (Priority: Loads > Battery > Grid)

The backup mode is suitable for areas with frequent power outages.

This mode will maintain the battery capacity at relatively high level to ensure that the emergency loads can be used when grid is off. Same working logic with self-use mode.

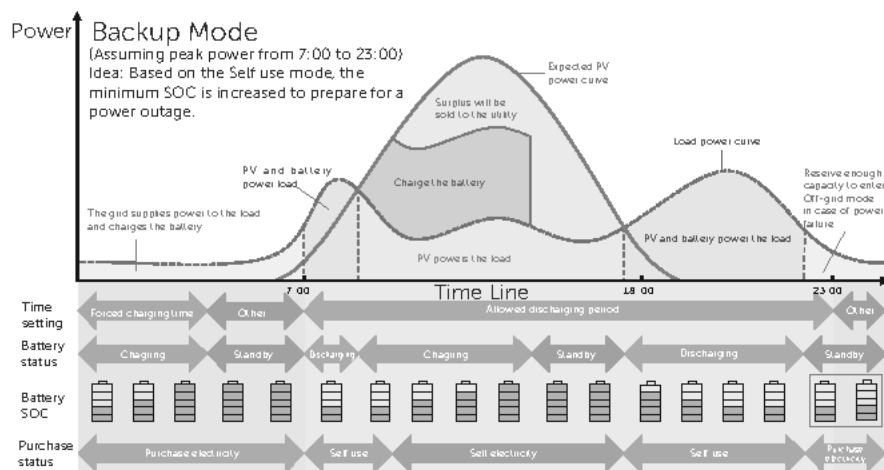

Figure 2-17 Backup mode

Table 2-14 Description of backup mode

Time period	Inverter working status
Forced charging period	<ul style="list-style-type: none"> Charge the battery firstly until the battery SOC reaches the specified Charge battery to value. You can configure the inverter to either draw power from the grid or not.
Allowed discharging period	<ul style="list-style-type: none"> The working logic remains the same as for self-use mode, but it enters a standby state when PV input is not available and the battery SOC reaches Min SOC (on-grid min SOC). In the event of a grid outage, it will switch to EPS mode until the battery discharges to Min SOC (Off-grid min SOC).

Note:

Min SOC (on-grid min SOC): Minimum SOC under grid connection. 30% by default, the settable range is 30%~100%.

Min SOC (off-grid min SOC): Minimum SOC under off-grid conditions. 10% by default, the settable range is 10%~100%.

NOTICE!

- You can set two configurable working periods: forced charging period and allowed discharging period in backup mode. Please refer to "Charge & Discharge Period" for details.

2.9.4 Peak Shaving Mode

Peak shaving mode is set for leveling out peaks in electricity use. The system is intelligently controlled to ensure charging takes place during off-peak hours and discharging occurs during peak hours.

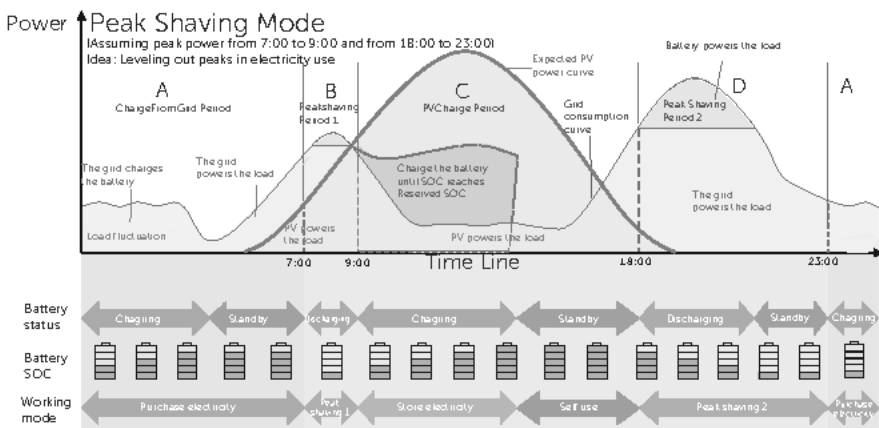

Figure 2-18 Peakshaving mode

Table 2-15 Description of peakshaving mode

Time Period	Inverter working status
Period A	<ul style="list-style-type: none"> The grid can charge the battery to MaxSOC within the set ChargePowerLimits. In this period, the battery will not discharge power.

Time Period	Inverter working status
Period B & D	Grid consumption power < PeakLimits (PV+grid → load) <ul style="list-style-type: none"> The PV and grid will power the load. The battery will not charge or discharge power.
	Grid consumption power > PeakLimits (PV + battery+grid → load) <ul style="list-style-type: none"> The battery will discharge energy for loads and thus reduce the amount of energy purchased from the grid.
Period C	(PV → battery → load → grid) <ul style="list-style-type: none"> The battery does not discharge power. The PV charges the battery up to the Reserved SOC before supplying power to the loads. Any excess power beyond the load requirements is fed into the grid.

Note:

MaxSOC: The energy taken from grid to charge the battery. 50% by default, the settable range is 10%-100%.

ChargePowerLimits: The charging power from grid. 1000 W by default, the settable range is 0-60000 W

PeakLimits: The load consumption from grid side. 0 W by default, the settable range: 0-60000 W.

Reserved SOC: The lower limit of battery SOC required for later peak shaving period. 50% by default, the settable range is 10~100%.

2.9.5 TOU Mode

In the TOU mode, different working modes, i.e Self-use, Feedin-priority, Peaking shaving, Charging and Discharging can be set for different time periods in accordance with actual needs and environment conditions through SolaXCloud App or Web.

The day can be divided into up to 24 time slots, and the minimum time slot is 15 minutes, independent working mode can be set for each time slot. Please refer to Web Guide or App Guide for details about how to set the TOU mode.

Time Slot	Working Mode
x:xx~x:xx (e.g 0:00~0:15)	Choose one mode from Self-use / Feedin-priority / Peaking shaving / Charging / Discharging

Note:

Self-use: Same working logic with "Self-use Mode", but it is not limited by the charging and discharging time slots. The priority of PV: Loads > Battery > Grid.

Feedin-priority: Same working logic with "Feedin-priority Mode", but it is not limited by the charging and discharging time slots. The priority of PV: Loads > Grid > Battery.

Peak Shaving: The working logic is that when the power consumption from the grid exceeds the set **PeakLimit** value, the battery is allowed to discharge power. The excess power beyond the limit is provided by the combination of photovoltaic and battery to ensure that the maximum power purchased from the grid does not exceed the set limit. You need to set the **PeakLimit** value through Web or App when choosing Peak Shaving mode.

Charging: The power of PV will charge the battery as much as possible to the set SOC of **Charge BAT to (%)**. You can set whether to Charge from grid. The default value of **Charge BAT to (%)** is 100%. When the battery reaches the set SOC, the surplus power will perform "Self-use Mode" or supply to the grid (based on the system setup), at this point, **Charge from grid** is not allowed.

Discharging: If allowed by the battery, the system outputs a specified power from the grid based on the set output percentage, controlling the power at the AC port. You need to set the **RatePower (%)** through Web or App when choosing Discharging mode. When the battery **Discharge to (%)** reaches the set SOC, the inverter performs "Self-use Mode".

2.9.6 EPS Mode (Priority: Loads > Battery)

During a power failure, the system will provide uninterrupted power supply to the EPS loads using the power from PV and the battery. It is important to ensure that a battery is installed, and the EPS loads should not exceed the maximum output power of the battery.

The power generated by PV will prioritize supplying power to the loads, while any surplus power will be utilized to charge the battery.

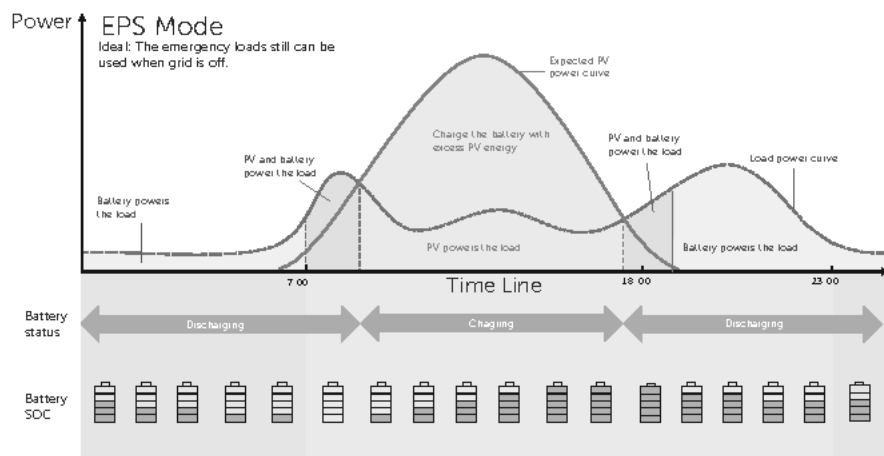

Figure 2-19 EPS mode

Table 2-16 Description of EPS mode

Battery SOC	Inverter working status
Battery SOC > Min SOC (off-grid min SOC)	<p>PV is sufficient (PV → load → battery)</p> <ul style="list-style-type: none"> The PV prioritizes supplying power to the load, with any excess energy being directed towards charging the battery.
Battery SOC < Min SOC (off-grid min SOC)	<p>PV is insufficient (PV+battery → load)</p> <ul style="list-style-type: none"> The PV prioritizes supplying power to the load. If the energy is not enough, the battery will discharge power until the battery SOC reaches Min SOC and then error of BatPowerLow will be reported.
Battery SOC < Min SOC (off-grid min SOC)	<p>The inverter reports BatPowerLow. When there is PV, it will charge the battery first. After charging to the set Min ESC SOC value, it will be automatically recovered and enter EPS mode again.</p>

Note:

Min SOC: Minimum SOC of the battery under off-grid conditions. 10% by default, the settable range: 10%-100%.

Min ESC SOC: The minimum SOC of the battery to enter EPS mode. 30% by default, the settable range: 15%-100%.

2.9.7 Manual Mode

This working mode is only for the after-sales team to do after-sales maintenance. It includes **Forced Discharge**, **Forced Charge** and **Stop chrg&dischrg**. The system will restore to the original working mode after six hours Manual mode set.

2.9.8 Export Control Function

Solar export control is a limit on the amount of energy that your solar system can export into the grid. You have a set limit on how much energy you can export to the grid.

How Export Control works

- CT/meter required
- Correct setting of the limit value of **Export Control** through inverter. (For parallel system, set on the master inverter)

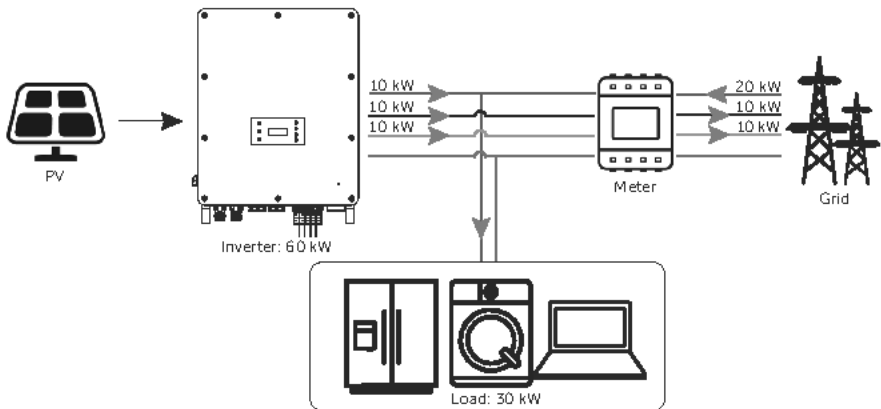

Figure 2-20 Zero export control with **Phase Unbalance** disabled

NOTICE!

- The power taken from the grid is equal to the power fed into the grid.

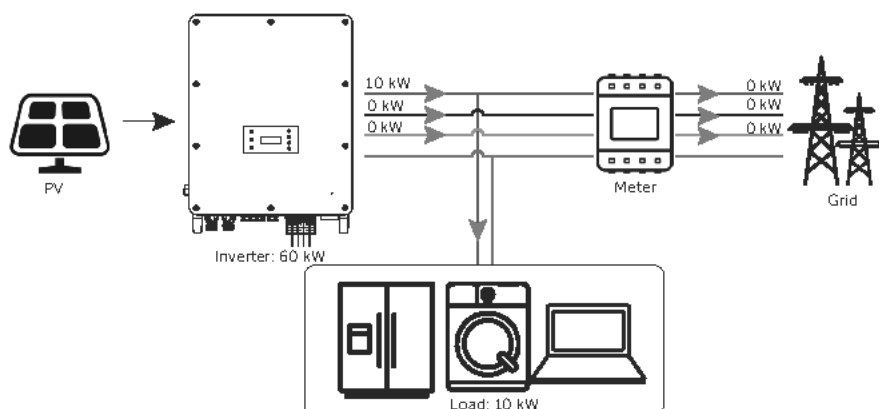

Figure 2-21 Zero export control with **Phase Unbalance** enabled

Note:

Export Control value can be set from 0W to more than the rated output power.

For how to set the **Export Control** function, please refer to "Setting Export Control".

2.10 Working Principle

2.10.1 Circuit Diagram

The inverter is equipped with multi-channel MPPT for DC input to ensure maximum power even under different photovoltaic input conditions. The inverter unit converts direct current into alternating current that meets the requirements of the power grid and feeds it into the power grid. The lightning arrester at AC / DC side realizes the function of surge protection.

The TSYS-HR143 battery system is equipped with a high-voltage box for optimal performance and maximises energy efficiency, and supports 7 to 14 battery packs for high capacity. The principle design of AELIO+HR140 system is shown in the figure below:

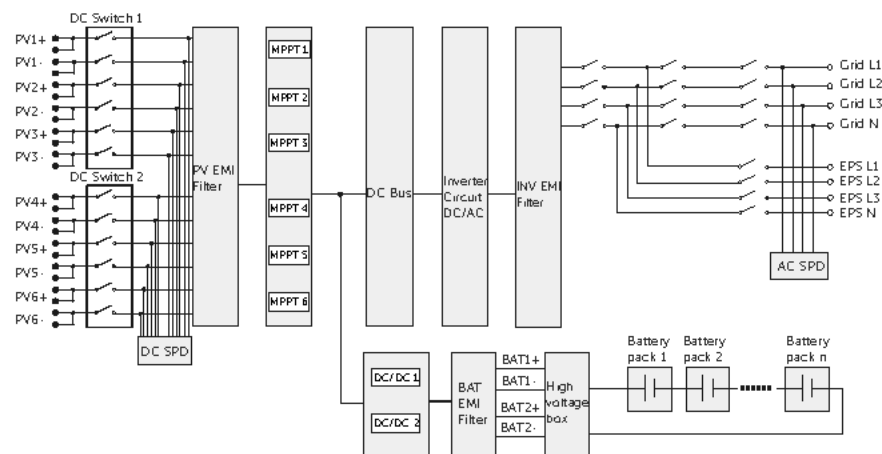

Figure 2-22 Circuit diagram for AELIO+HR140 system

NOTICE!

- MPPT 6 is unavailable for the X3-AELIO-49.9K and X3-AELIO-50K inverter but available for the X3-AELIO-60K inverter.

2.10.2 Application Schemes

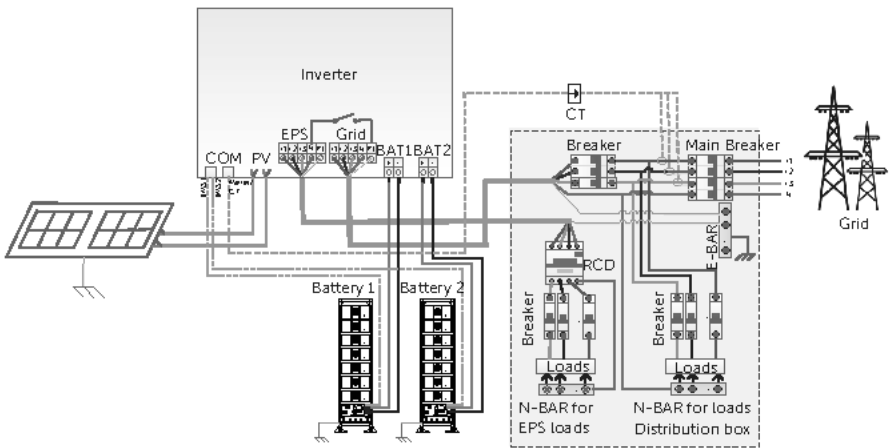

Figure 2-23 Partial home backup for Europe

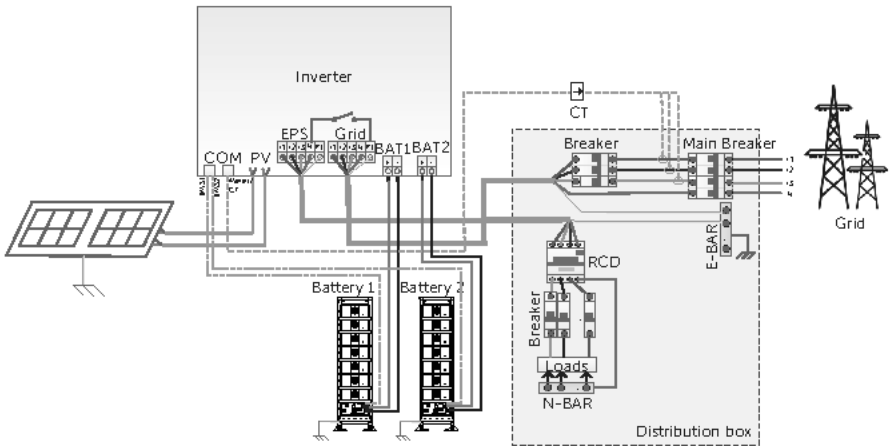

Figure 2-24 Whole home backup for Europe

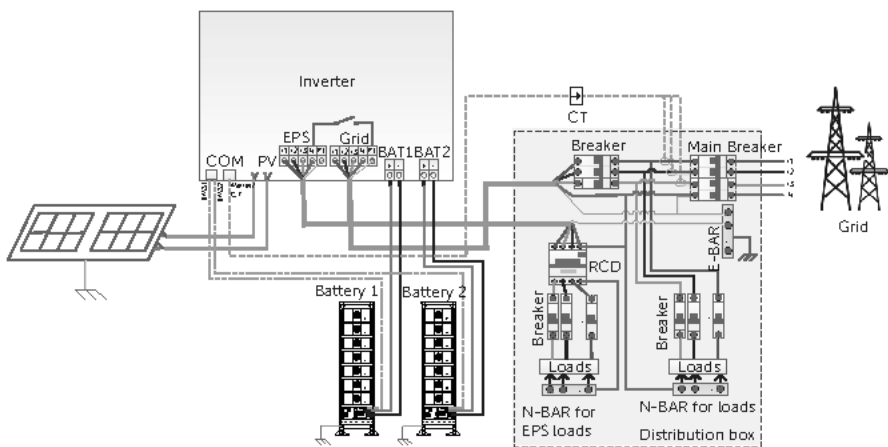

Figure 2-25 Partial home backup for Australia

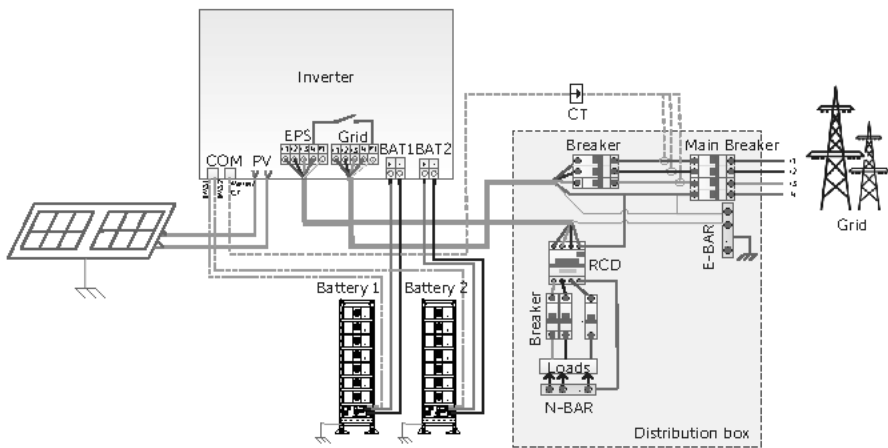

Figure 2-26 Whole home backup for Australia

NOTICE!

- The BAT 1 and BAT2 terminals of the inverter are positioned vertically, with the positive pole on the left side and the negative pole on the right side.

3 Transportation and Storage

3.1 Transportation

3.1.1 Inverter Transportation

If the inverter is not put into use immediately, the transportation and storage requirements needs to be met:

- The inverter must be transported in its original packaging. SolaX will not be held responsible for any damage to the inverter caused by improper transportation or by transportation after it has been installed.
- Observe the caution signs on the packaging of inverter before transportation.
- Pay attention to the weight of inverter. Be cautious to avoid injury when carrying X3-AELIO (gross weight: 130 kg). Lifting device is recommended.
- The inverter with a package should be transported by forklift to the location where it needs to be placed.

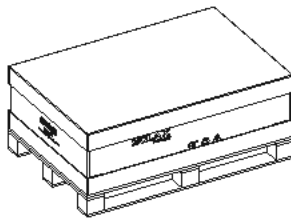

Figure 3-1 Caution signs on the packaging

3.1.2 Battery Transportation



- Please be careful to avoid physical collisions during transportation. Do not place the equipment upside down, be exposed to water, etc., which may result in equipment damage, or even a fire or an explosion.

NOTICE!

- Please strictly comply with the transportation requirements of the warning signs on the packaging and equipment.
- To reduce product damage caused by shocking, tilting or impacting during transportation, it is recommended to consider sea or road (with better conditions) transport instead of rail and air transports.

NOTICE!

Transportation requirements for battery:

- Relevant qualifications for the transport of dangerous goods must be obtained by the forwarding agent engaged in such businesses, and they must strictly abide by the local regulations for the transport of dangerous goods.
- Please check the battery before transportation. If a battery leaks, smells, or is damaged, do refuse to transport it.
- Please handle gently in the process of loading and unloading, transportation, and moving a battery to prevent bumping, and take effective moisture-proof measures to prevent personal injuries and battery damage.
- Unless otherwise specified, do not transport the batteries, which are classified as dangerous goods, together with food, medicine, or other additives on the same means of transport.

Manual handling

- Please choose an appropriate transport method based on site conditions and device weight.
- Please wear PPE (eg. protective gloves, shoes, belt, etc.) and lift the device with proper postures, to prevent personal injuries and device damage.
- Please reasonably arrange the number of workers and the handling position to achieve distributing weight and balancing load when moving the device.
- Please hold the handles or the bottom of the device when moving, to avoid device damage.
- Please pay attention to the surrounding environment when moving, such as obstacles, slippery ground, etc., to avoid personal injuries and device damage.

Forklift

- Please confirm the forklift's load-bearing capacity shall be > 2 t before using it.
- Before moving the device, please pay attention to the center of gravity position of the load, and fully secure the load on the forklift by securing measures, such as ropes or bindings. In addition, please designate a person to supervise for safety concerns during transportation.

3.2 Storage

3.2.1 Inverter Storage

- The inverter must be stored indoors.
- Do not remove the original packaging material and check the outer packaging material regularly.
- The storage temperature should be between -40°C and $+70^{\circ}\text{C}$. The humidity should be between 0% and 65%.
- Stack the inverter in accordance with the caution signs on the inverter carton to prevent their falling down and device damage. Do not place it upside down.

3.2.2 Battery Storage

DANGER!

- The battery must be stored indoors, which the environment should meet the following requirements: 1. Avoiding direct sunlight and keeping out of rain; 2. Dry and well-ventilated; 3. Keeping away from heat and fire sources; 4. Keeping away from radiation; 5. Keeping away from chemicals; 6. Keeping away from dust and metal conductive dust; 7. Being equipped with fire facilities.
- Batteries must be stored in accordance with the requirements of the warning signs and other information on the packaging.
- Do not store with any other electronic equipment, chemicals, or other items that may cause interference or danger.
- Please pay attention to the height when stacking batteries to avoid deforming or damaging the battery at the bottom.

NOTICE!

- Do not store the batteries for a long time. If long periods of storage are unavoidable, please recharge it periodically to avoid battery damage.

- Regarding with the storage information, see the following table:

Table 3-1 Storage information

Storage temperature range	Storage time
30°C to 50°C	6 months
-20°C to 30°C	12 months

- Relative humidity for device storage: 5% ~ 95% (packaged storage).
- if the battery has been stored for more than 1 year, it must be checked and tested

by professionals before use.

Table 3-2 Maintenance of battery pack

Circumstance	Measure
If the ambient temperature for storage is between 30°C and 50°C	Recharge the battery packs at least once every 6 months
If the ambient temperature for storage is between -20°C and 30°C	Recharge the battery packs at least once every 12 months.
In the first installation	The interval among manufacture dates of battery packs shall not be exceed 3 months.
If a battery module is replaced or added for capacity expansion	Each battery's SOC should be consistent. The max. SOC difference should be $\pm 5\%$.
If users want to increase their battery system capacity	Ensure that the SOC of the existing system capacity is about 40%. The manufacture date of the new battery pack shall not exceed 6 months. If the manufacture date of the new one exceeds 6 months, please charge it to around 40%.

4 Preparation before Installation

4.1 Installation Options

NOTICE!

- AELIO+HR140 system can match 7~14 battery packs. "Option A" is for one bracket and "option B / C / D / E / F / G / H" is for dual bracket.

There are 8 installation options available, with details as follows:

One bracket

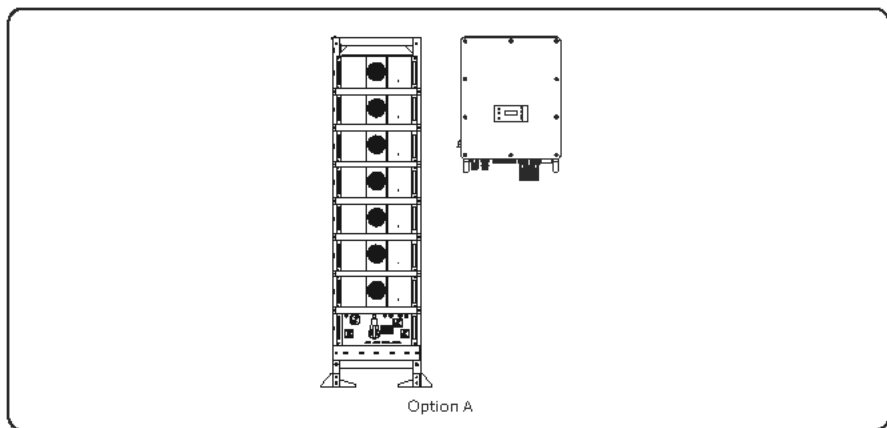

Figure 4-1 Installation options for one bracket

Dual bracket

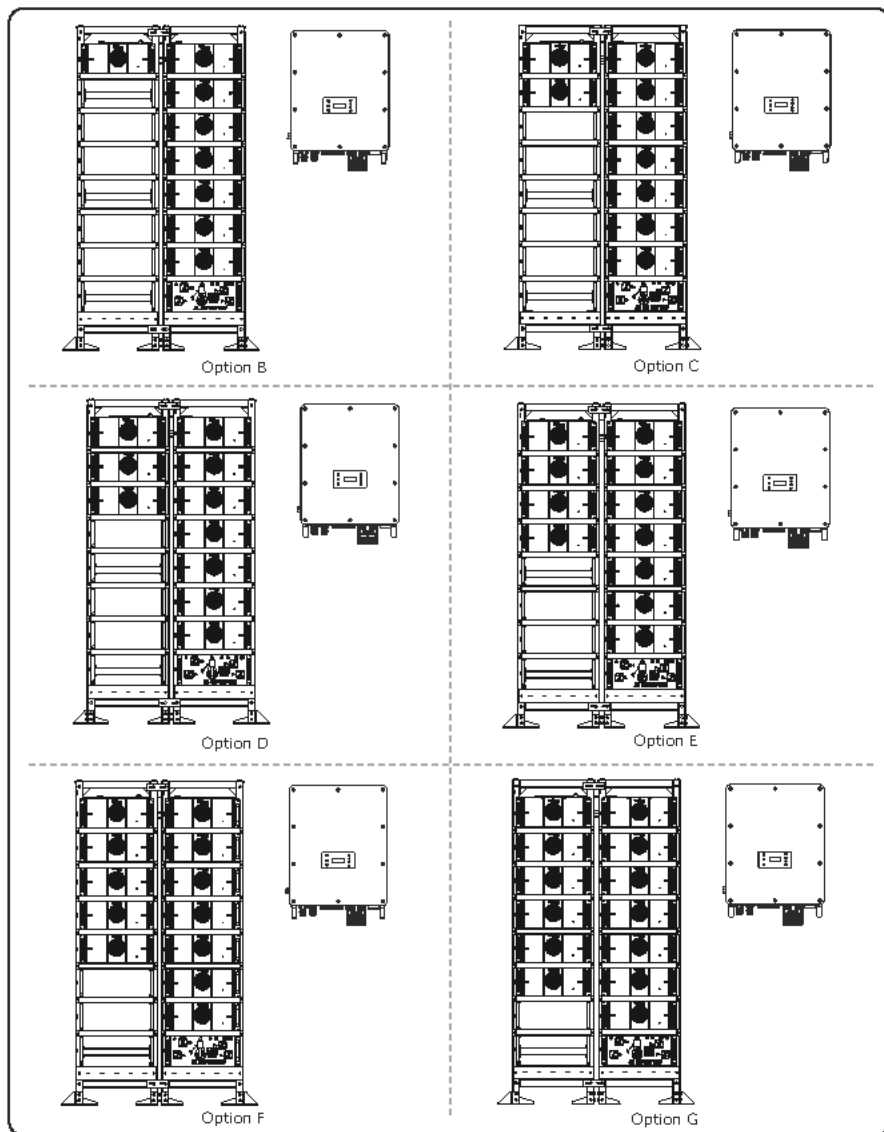

Figure 4-2 Installation options for dual bracket

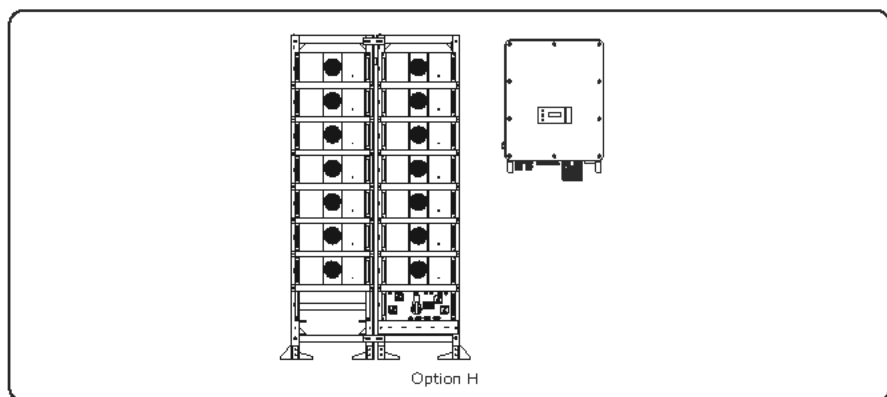

Figure 4-3 Installation options for dual bracket

Table 4-1 Number of components

	Option A	Option B	Option C	Option D	Option E	Option F	Option G	Option H
Inverter	1	1	1	1	1	1	1	1
Battery system model	T-HR100.1	T-HR114.4	T-HR128.7	T-HR143.0	T-HR157.3	T-HR171.6	T-HR185.9	T-HR200.2
High-voltage box	1	1	1	1	1	1	1	1
Battery packs	7	8	9	10	11	12	13	14
Bracket	1	2	2	2	2	2	2	2

Table 4-2 Net weight of one bracket

	Option A
Net weight [kg]	1050

Table 4-3 Net weight of dual bracket

	Option B	Option C	Option D	Option E	Option F	Option G	Option H
Net weight [kg]	1146.6	1261.6	1376.6	1491.6	1606.6	1721.6	1836.6

4.2 Selection of Installation Location

The installation location selected for the device is quite critical in the aspect of the guarantee of machine safety, service life and performance, which shall be convenient for wiring connection, operation and maintenance.

Inverter environment requirement

Make sure the installation site meets the following conditions:

- The ambient temperature: -35°C to $+60^{\circ}\text{C}$;
- The relative humidity shall be between 0-100%RH;
- Do not install the inverter in the areas where the altitude exceeds 3000 m;
- Install the inverter in a well-ventilated environment for heat dissipation. You are recommended to install an awning over the inverter if it is installed on a support outdoors;
- X3-AELIO series inverter has the IP66 ingress protection, which allows it to be installed outdoors;
- Do not install the inverter in areas with flammable, explosive and corrosive materials or near antenna.

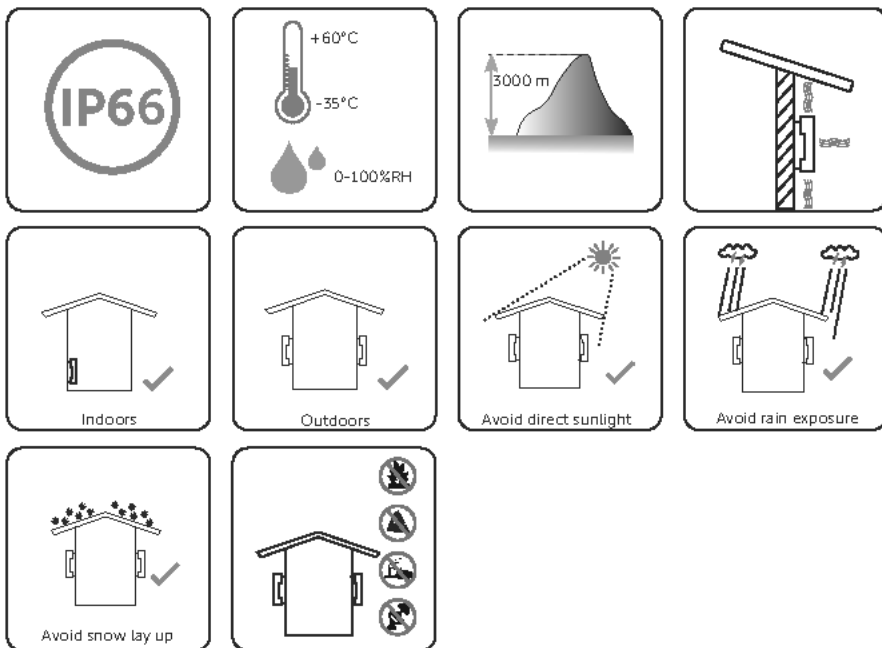

NOTICE!

- For outdoor installation, precautions against direct sunlight, rain exposure and snow accumulation are recommended.
- Exposure to direct sunlight raises the temperature inside the device. This temperature rise poses no safety risks, but may impact the device performance.
- Install the inverter at least 500 meters away from the coast and avoid sea breeze directly hit.

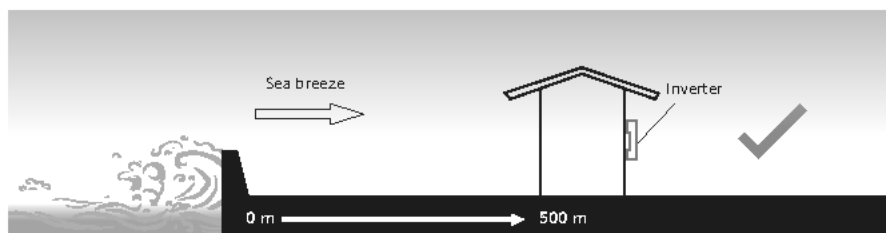

Figure 4-4 Recommended installation position

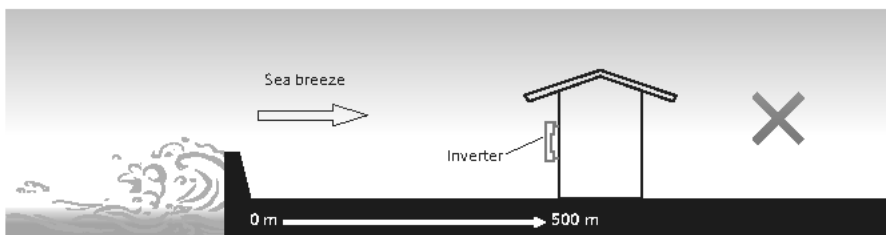
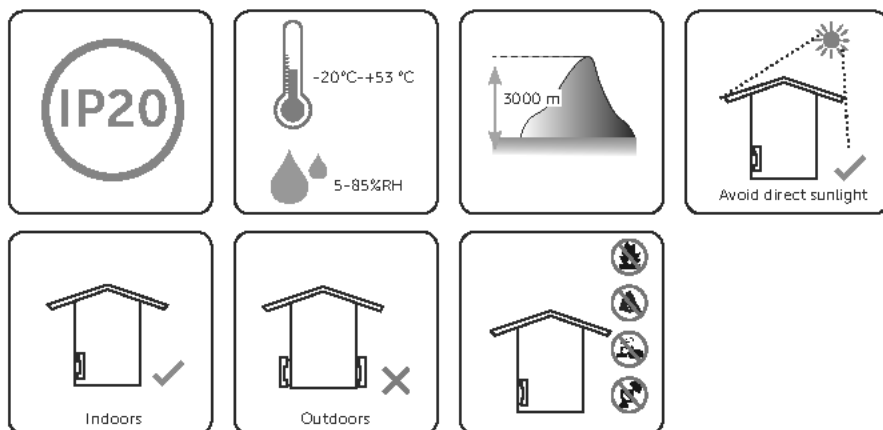

Figure 4-5 Incorrect installation position

Battery environment requirement

Make sure the installation site meets the following conditions:

- The ambient temperature: -20°C to $+53^{\circ}\text{C}$;
- The humidity shall be between 5-85%;
- Do not install the battery in the areas where the altitude exceeds 3000 m;
- Area accessible only to electrically skilled persons and electrically instructed persons with the proper authorization;
- Avoid direct sunlight;
- Flaunting an IP20 enclosure, the battery can only be used indoors;
- Do not install the battery in areas with flammable, explosive and corrosive materials or near antenna.



NOTICE!

- In a high temperature environment above 45°C , the battery may shed load during operation.

4.2.1 Installation Carrier Requirement

Inverter installation carrier requirement

The installation carrier must be made of a non-flammable material, such as solid brick, concrete, etc. and be capable of supporting the weight of the inverter and suitable of the dimensions of the inverter. If the wall strength is not enough, (such as wooden wall, the wall covered by thick layer of decoration) it must be strengthened additionally.

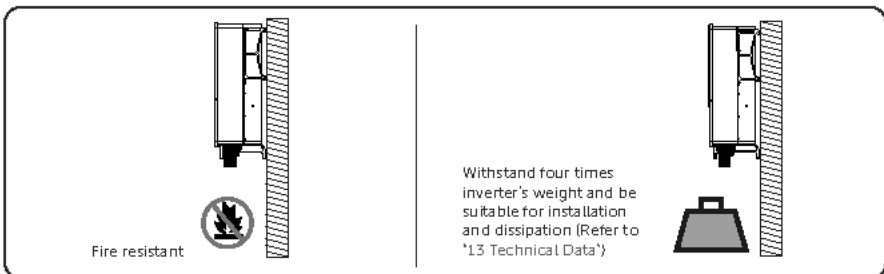

Figure 4-6 Installation carrier requirement

NOTICE!

- Please take the weight of battery into account when wall-mounting the whole system.

Battery installation carrier requirement

The mounting location must be suitable for the weight and dimensions of the product and the support surface for installation must be made of a non-flammable material.

- Solid brick/concrete, or mounting surface with equivalent strength;
- Please ensure that the thickness of any part of the wall should not be less than 150 mm;
- The bearing capacity of the ground for one bracket must be over 1500 kg; The bearing capacity of the ground for dual bracket must be over 3000 kg.
- The device must not be installed on the wood wall.

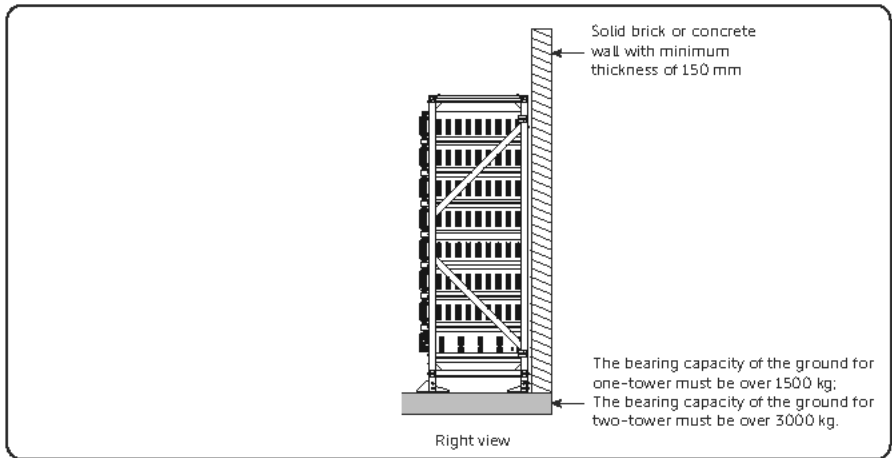

Figure 4-7 Installation carrier requirement

4.2.2 Clearance Requirement

Inverter clearance requirement

The minimum clearance reserved for the connected terminal at the bottom of inverter and the bending radius of the wires should be no less than 80 cm.

To guarantee proper heat dissipation and ease of disassembly, the minimum space around the inverter must meet the standards indicated below.

For installations with multiple inverters, two installation modes are taken for an example below. When the space is sufficient, Figure 4-9 is recommended. When the space is insufficient, Figure 4-10 is recommended. Please make sure to leave the minimum space among inverters marked on the figure below. In areas with high ambient temperatures, increase the clearances between the inverters and provide adequate fresh air ventilation if feasible.

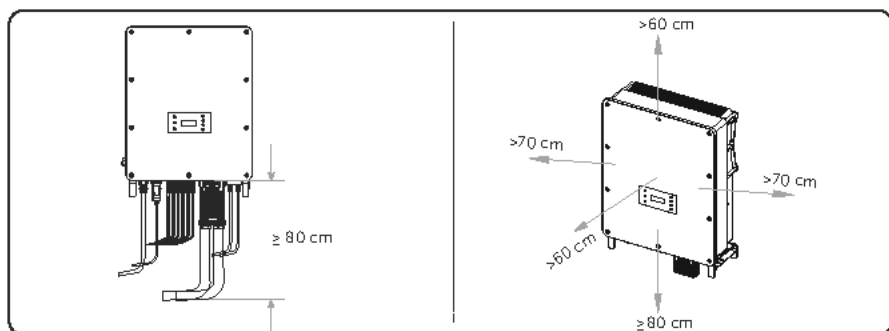

Figure 4-8 Clearance requirement for single inverter

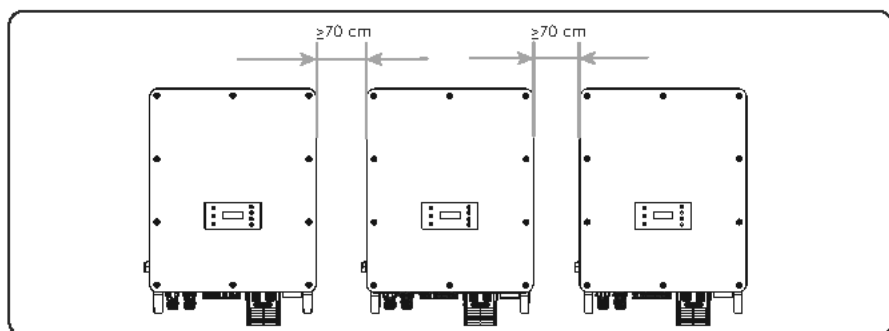

Figure 4-9 Clearance requirement for multiple inverters

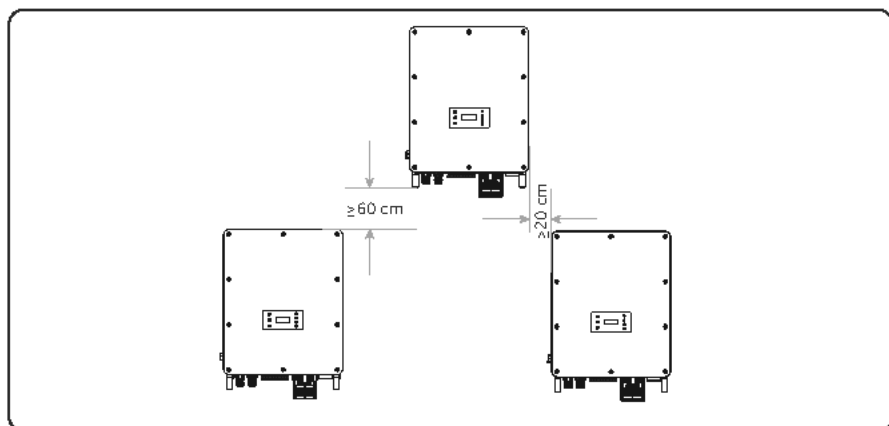

Figure 4-10 Clearance requirement for multiple inverters

Battery clearance requirement

To guarantee proper heat dissipation and ease of disassembly, the minimum space around the bracket must meet the standards indicated below.

- At least a distance not less than 830 mm shall be provided to give access to the bracket for installation and maintenance.
- At least a distance between 13 and 30 mm shall be provided between the wall and the bracket for heat dissipation.

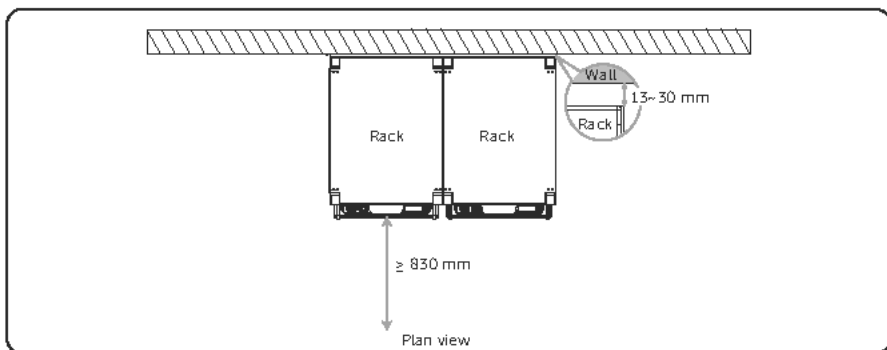
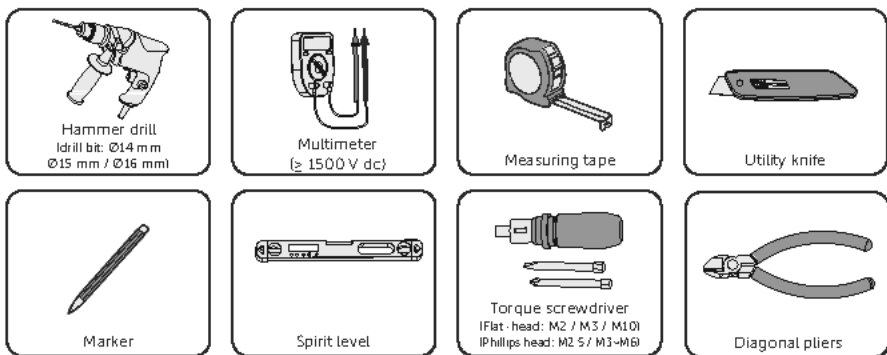

Figure 4-11 Installation space

4.3 Tools Requirement









Installation tools include but are not limited to the following recommended ones. If necessary, use other auxiliary tools on site.





4.4 Additionally Required Materials

Table 4-4 Additionally required wires

No.	Required Material	Type	Conductor Cross-section
1	PV wire	 Dedicated PV wire with a voltage rating of 1000 V, a temperature resistance of 105°C, a fire resistance grade of VW-1	6 mm ²
2	Communication wire 1	 Network cable CAT5E	/
3	Communication wire 2	 Four-core signal cable	0.25 mm ² -0.3 mm ²
4	Grid and EPS wire	 Five-core copper cable	35 mm ²
5	Additional PE wire	 Conventional yellow and green wire	25 mm ²
6*	Battery power cable (for capacity expansion only)	 One-core copper cable	26.7±2 mm ²
7	Grounding plate	 Copper bar	Width: 40 mm Depth: 4mm
8	Protective pipe	 /	Inner diameter: Over 50 mm

NOTICE!

- The battery power cable needs to be prepared when the system needs capacity expansion.

Table 4-5 Circuit breaker recommended for Grid connection

Model	49.9 kW	50 kW	60 kW
Circuit breaker 	> 100A	> 100A	> 125A

Table 4-6 Micro-breaker recommended for EPS connection



Model	49.9 kW	50 kW	60 kW
Circuit breaker 	> 100A	> 100A	> 125A

Table 4-7 RCD recommended

Model	49.9 kW	50 kW	60 kW
RCD 	< 500 mA	< 500 mA	< 600 mA

5 Unpacking and Inspection

5.1 Battery Unpacking

Please check whether the number of cartons received are correct before unpacking. For details, please refer to the following table.

Table 5-1 Number of cartons

Configuration		Cartons	
One bracket	One bracket carton	A high-voltage box carton	battery cartons
Dual bracket	Two bracket cartons	A high-voltage box carton	battery cartons

NOTICE!

- The number of battery cartons depends on how many battery packs the users purchased.

5.1.1 Unpacking

- Unpack cartons according to the following figures.

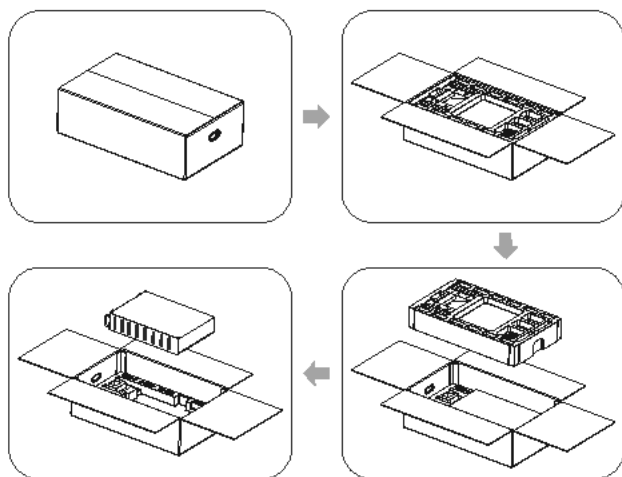

Figure 5-1 Unpacking cartons

- The rechargeable battery packs undergoes 100% testing and inspection before

shipping from the manufacturing facility. However, transport damage may still occur. Before unpacking, please verify that the model and outer packing materials for damage, such as holes and cracks.

- Be careful when dealing with all package materials which may be reused for storage and relocation in the future.
- Upon opening the package, check whether the appearance is damaged or lack of accessories. If any damage is found or any parts are missing, contact your dealer immediately.

5.1.2 Scope of Delivery

Bracket

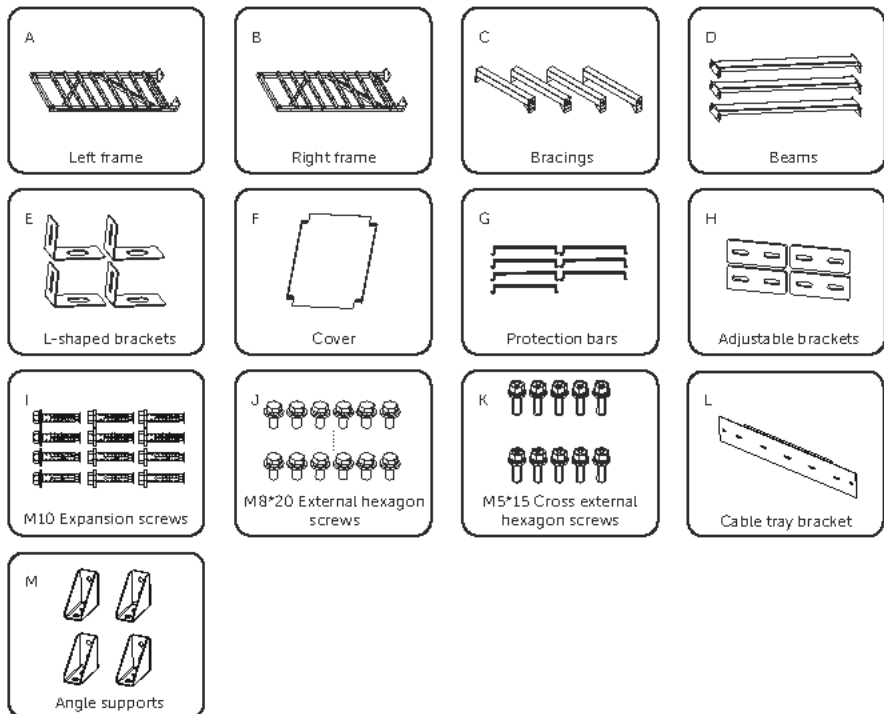

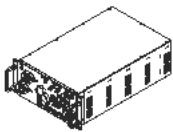
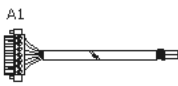





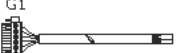

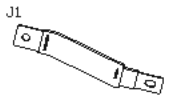

Table 5-2 Packing list of bracket

Item	Description	Quantity
A	Left frame	1pc

Unpacking and Inspection

Item	Description	Quantity
B	Right frame	1 pc
C	Bracing	4 pcs
D	Beam	3 pcs
E	L-shaped bracket	4 pcs
F	Cover	1 pc
G	Protection bar	7 pcs
H	Adjustable bracket	4 pcs
I	M10 Expansion screw	15 pcs
J	M8*20 External hexagon screw	70 pcs
K	M5*15 Cross external hexagon screw	70 pcs
L	Cable tray bracket	1 pc
M	Angle support	4 pcs

High-voltage box

 <p>High-voltage box</p>	 <p>A1 Communication cable (high-voltage box to battery pack) (550 mm)</p>	 <p>B1 Communication cable (high-voltage box to inverter) (19.6±5mm³) (2000 mm)</p>	 <p>C1 Fan power cable (AC input port) (36.2±1.5mm³) (2000 mm)</p>
 <p>D1 Power cable (+) (high-voltage box to inverter) (91.5±10mm³) (2300 mm)</p>	 <p>E1 Power cable (-) (high-voltage box to inverter) (91.5±10mm³) (2300 mm)</p>	 <p>F1 Grounding cable (for rack) (55±5mm³) (1000 mm)</p>	 <p>G1 Fan power cable (high-voltage box to battery pack) (117.3±1.5*3mm³) (2300 mm)</p>
 <p>H1 Power cable (-) (high-voltage box to battery pack) (151±10mm³) (2300 mm)</p>	 <p>I1 Terminal resistance</p>	 <p>J1 Copper bar (high-voltage box to battery pack)</p>	 <p>K1 Removal tool for PV connectors</p>

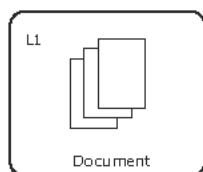

Table 5-3 Packing list of high-voltage box

Item	Description	Quantity
/	High-voltage box	1 pc
A1	Communication cable (high-voltage box to battery pack) (550 mm)	1 pc
B1	Communication cable (high-voltage box to inverter) ($19.6 \pm 5 \text{mm}^2$) (2000 mm)	1 pc
C1	Fan power cable (AC input port) ($36.2 \pm 1.5 \text{mm}^2$) (2000 mm)	1 pc
D1	Power cable (+) (high-voltage box to inverter) ($91.5 \pm 10 \text{mm}^2$) (2300 mm)	1 pc
E1	Power cable (-) (high-voltage box to inverter) ($91.5 \pm 10 \text{mm}^2$) (2300 mm)	1 pc
F1	Grounding cable (for bracket) ($55 \pm 5 \text{mm}^2$) (1000 mm)	1 pc
G1	Fan power cable (high-voltage box to battery pack) [$(17.3 \pm 1.5) \times 3 \text{mm}^2$] (2300 mm)	1 pc
H1	Power cable (-) (high-voltage box to battery pack) ($151 \pm 10 \text{mm}^2$) (2300 mm)	1 pc
I1	Terminal resistance	1 pc
J1	Copper bar (high-voltage box to battery pack)	1 pc
K1	Removal tool for PV connectors	1 pc
L1	Document	/

Battery pack

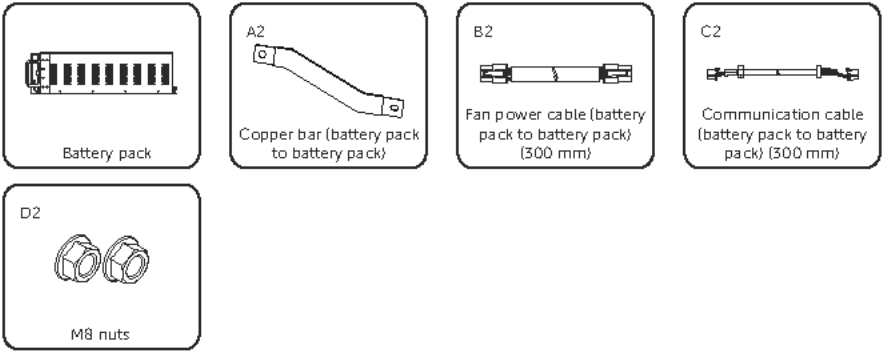

Table 5-4 Packing list of battery pack

Item	Description	Quantity
/	Battery pack	1 pc
A2	Copper bar (battery pack to battery pack)	1 pc
B2	Fan power cable (battery pack to battery pack) (300 mm)	1 pc
C2	Communication cable (battery pack to battery pack) (300 mm)	1 pc
D2	M8 nut	2 pcs

Accessory kit for dual bracket battery system (optional)

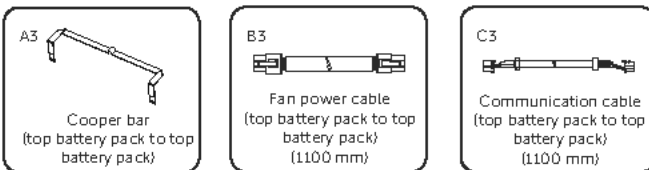

Table 5-5 Packing list of accessory kit for dual bracket battery system

Item	Description	Quantity
A3	Copper bar	1 pc
B3	Fan power cable (top battery pack to top battery pack) (1100 mm)	1 pc
C3	Communication cable (top battery pack to top battery pack) (1100 mm)	1 pc

NOTICE!

- When the system is dual bracket system, the accessory kit for dual bracket battery system is standard.

Accessory kit for dual battery cluster (optional)

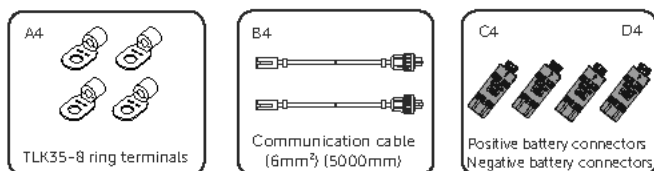

Table 5-6 Packing list of accessory kit for dual battery cluster

Item	Description	Quantity
A4	TLK35-8 ring terminal	4 pcs
B4	Communication cable (6mm ²) (5000mm)	2 pcs
C4	Positive battery connector	2 pcs
D4	Negative battery connector	2 pcs

NOTICE!

- When the system needs capacity expansion, the accessory kit for dual battery cluster is standard.
- For capacity expansion procedure, please refer to "14.3 Capacity Expansion".

5.2 Inverter Unpacking

5.2.1 Unpacking

- The inverter undergoes 100% testing and inspection before shipping from the manufacturing facility. However, transport damage may still occur. Before unpacking the inverter, please check the outer packing materials for damage, such as holes and cracks.
- Unpacking the inverter according to the following figure.

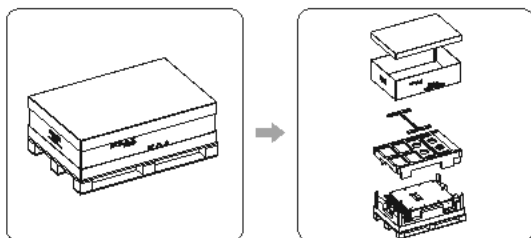
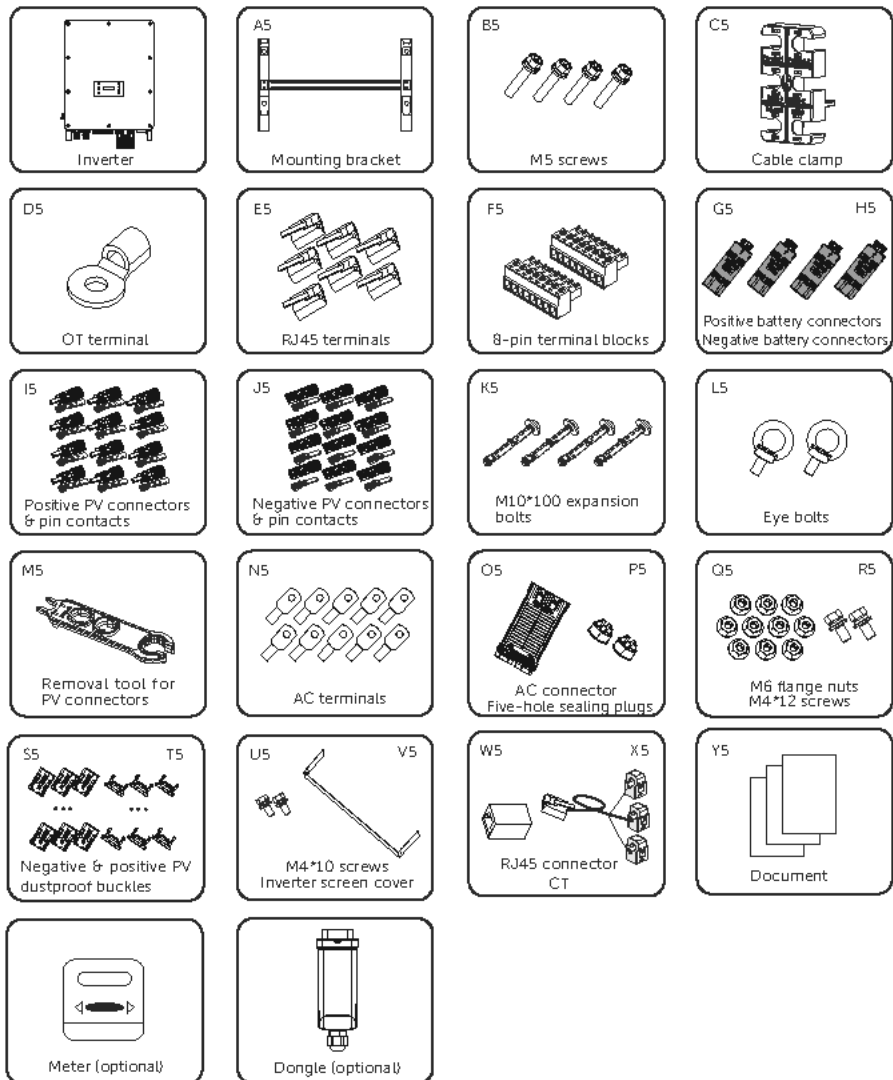

Figure 5-2 Unpacking the inverter

- Be careful when dealing with all package materials which may be reused for storage and relocation of the inverter in the future.
- Upon opening the package, check whether the appearance of the inverter is damaged or lack of accessories. If any damage is found or any parts are missing, contact your dealer immediately.

5.2.2 Scope of Delivery



* Refer to the actual delivery for the optional accessories.

Table 5-7 Packing list

Item	Description	Quantity
/	Inverter	1 pc

Unpacking and Inspection

Item	Description	Quantity
A5	Mounting bracket	1 pc
B5	M5 screw	4 pcs
C5	Cable clamp	1 pc
D5	OT terminal	1 pc
E5	RJ45 terminal	7 pcs
F5	8-pin terminal block	2 pcs
G5	Positive battery connector	2 pcs
H5	Negative battery connector	2 pcs
I5	Positive PV connector & pin contact	10 pairs for X3-AELIO-49.9K and X3-AELIO-50K 12 pairs for X3-AELIO-60K
J5	Negative PV connector & pin contact	10 pairs for X3-AELIO-49.9K and X3-AELIO-50K 12 pairs for X3-AELIO-60K
K5	M10*100 expansion bolt	4 pcs
L5	Eye bolt	2 pcs
M5	Removal tool for PV connectors	1 pc
N5	AC terminal	10 pcs
O5	AC connector	1 pc
P5	Five-hole sealing plug	2 pcs
Q5	M6 screw	10 pcs
R5	M4*12 screw	2 pcs
S5	Negative PV dustproof buckle	12 pcs
T5	Positive PV dustproof buckle	12 pcs
U5	M4*10 screw	2 pcs
V4	Inverter screen cover	1 pc
W5	RJ45 connector	1 pc
X5	CT	1 pc
Y5	Document	/
/	Meter (optional)	1 pc
/	Dongle (optional)	1 pc

6 Mechanical Installation

WARNING!

- Only the qualified personnel can perform the mechanical installation following the local standards and requirements.
- Check the existing power cables or other piping in the wall to prevent electric shock or other damage.

CAUTION!

- Always be aware of the weight of the battery. Personal injuries may result if the battery is lifted improperly or dropped while being transported or mounted.
- Use insulated tools and wear individual protective tools when installing the battery.

NOTICE!

- For installation dimension, please refer to "2.4 Appearance and Dimension".
- For device handling requirements, please refer to "3.1 Transportation".
- It is recommended to organize two people to push the battery pack into the bracket due to its net weight of 115 kg.
- **If the battery pack is carried manually, it is recommended to organize four people to lift, and install it from the down to the top.**
- **The site for installing the battery pack must be level (no slope, no pothole).**

6.1 Screws and Torques

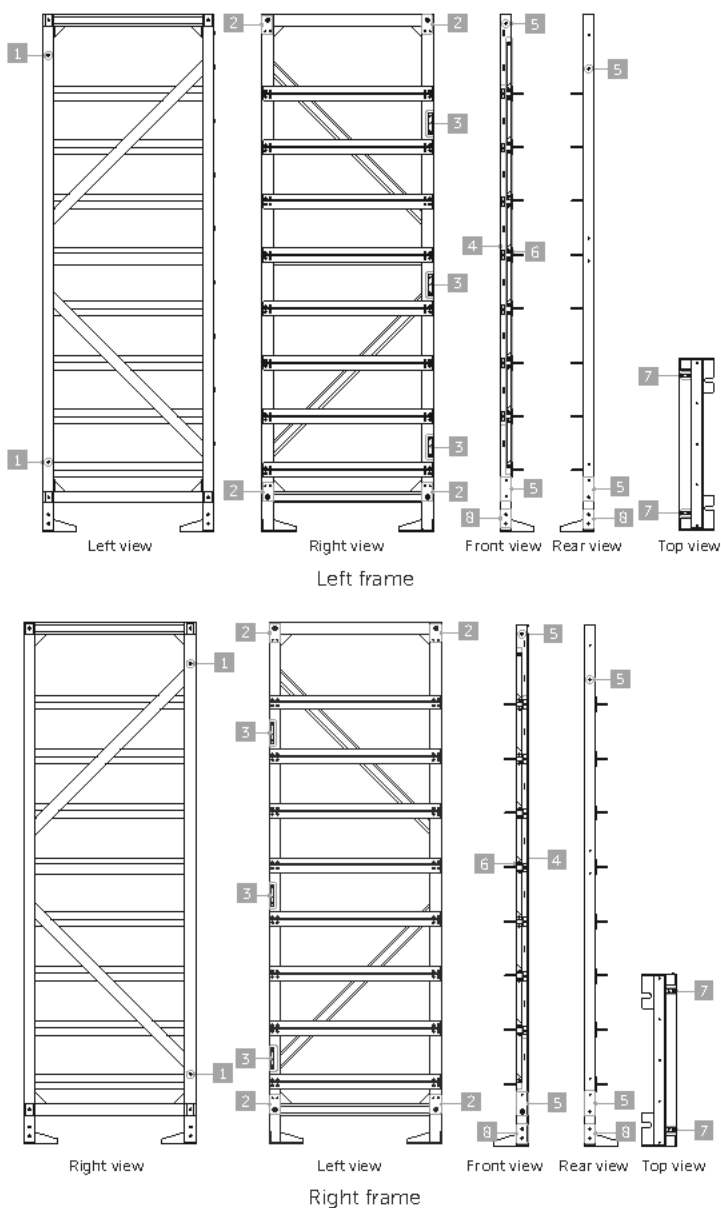

Figure 6-1 Screws for assembling the bracket

Table 6-1 Screws and torques

No.	Description	Screw Size	Torque (N.m)
1	To secure L-shaped bracket	M8 (to the frame)	12±1.2
		M10 (to the wall)	24±2.4
2	To secure the bracing	M5	3±0.3
3	To secure beam	M5	3±0.3
4	To secure protection bar	M5	3±0.3
5	To secure adjustable bracket	M8	12±1.2
6	To secure high-voltage box or battery pack	M8	12±1.2
7	To secure cover	M5	3±0.3
8	To secure angle support	M8 (to the frame)	12±1.2
		M10 (to the ground)	24±2.4

NOTICE!

- For dual bracket battery system installation procedure, please refer to "6.3 Dual bracket Battery System Installation".

6.2 One bracket Battery System Installation

- Step 1:** Attach left and right bracket frame (Part A and B) and bracing (Part C) (4 pcs). Firstly, secure M5 screws (Part K) into screw holes on both sides of bracket and bracing, but not fully tighten the screws on one side. Secondly, secure and fully tighten the screws on the other side. Finally, fully tighten all the screws with a torque wrench (torque: 3 ± 0.3 N·m).
- Step 2:** Attach left and right bracket frame (Part A and B) and beam (Part D) (3 pcs). Firstly, secure M5 screws (Part K) into screw holes on both sides of bracket and beam, but not fully tighten the screws on one side. Secondly, secure and fully tighten the screws on the other side. Finally, fully tighten all the screws with a torque wrench (torque: 3 ± 0.3 N·m).

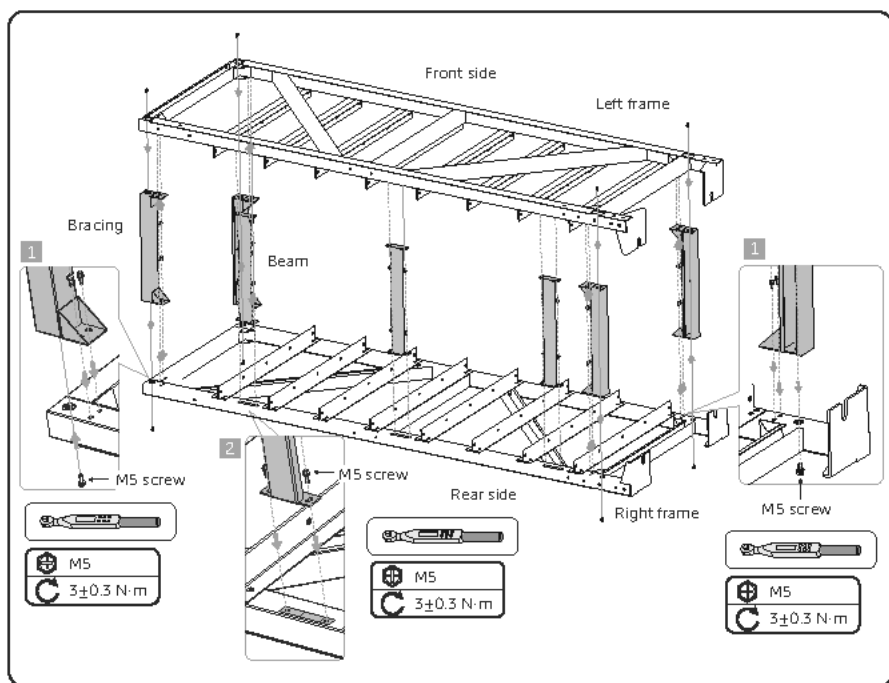

Figure 6-2 Assembling the bracket

Step 3: Attach the cover (Part F) by inserting and tightening M5 screws (Part K) (8 pcs) with a torque wrench (torque: 3 ± 0.3 N·m).

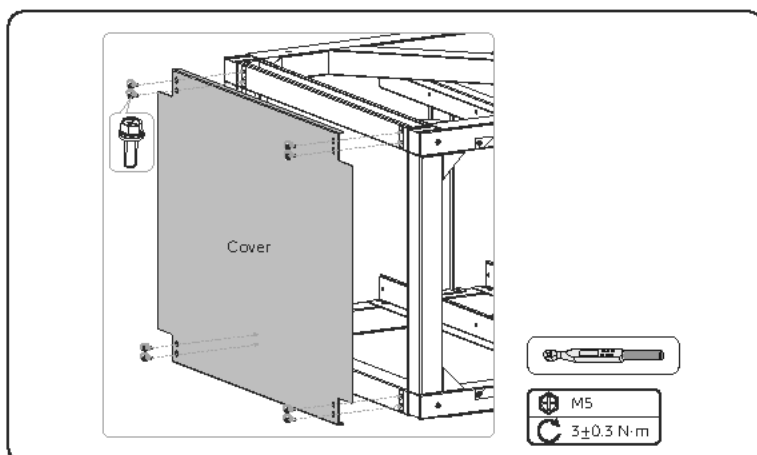

Figure 6-3 Attaching the cover

NOTICE!

- When attaching the cover, press the cover by hand to ensure that the holes can be correctly aligned and screws can be securely inserted into the holes on the bracket.

- Step 4:** After determining the installation position of the bracket, align the holes on the angle support (Part M) with the holes on the bracket, and secure M8 screws (Part J) (8 pcs), but do not fully tighten them.
Draw circles on the bottom of angle supports.
There are totalling four angle supports for a bracket.

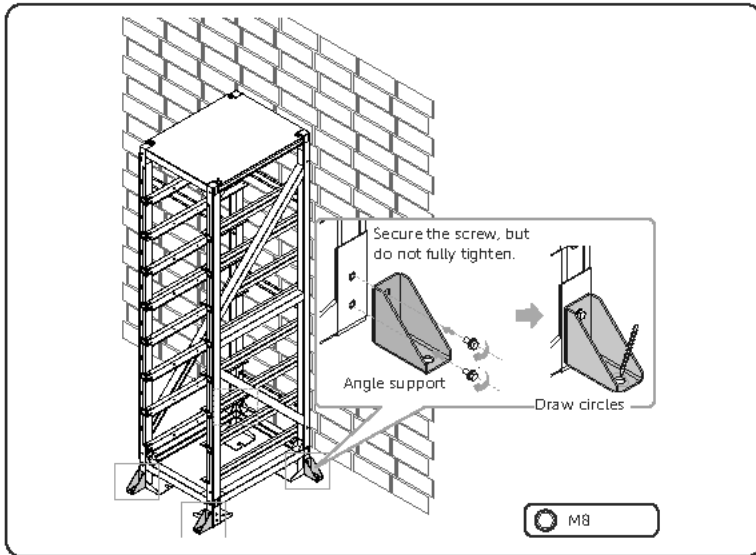

Figure 6-4 Drawing circles

NOTICE!

Installation options of angle supports:

- One bracket (not installed against the wall): all angle supports can be left or right.
- One bracket (installed against the wall):
 - Option a: all angle supports can be left or right.
 - Option b: two angle supports against the wall are left or right, and the remaining angle supports in the front side are forward.

If the bracket is not installed against the wall, please skip Step 5, 6, 8 and 11.

- Step 5:** Attach the L-shaped bracket (Part E) to the bracket, and insert M8 screws (Part J) (4 pcs), but do not fully tighten.
There are totalling four L-shaped brackets for a bracket.

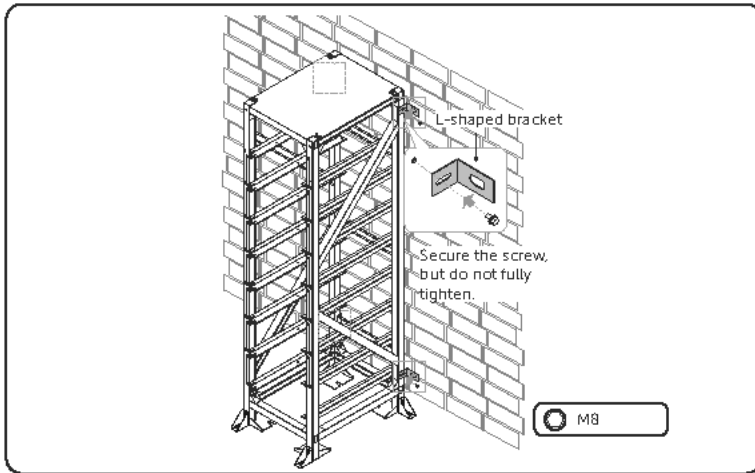

Figure 6-5 Securing M8 screws

- Step 6:** Place a spirit level to check whether L-shaped brackets are even. Draw circles along the inner ring of the holes on L-shaped brackets on the wall.

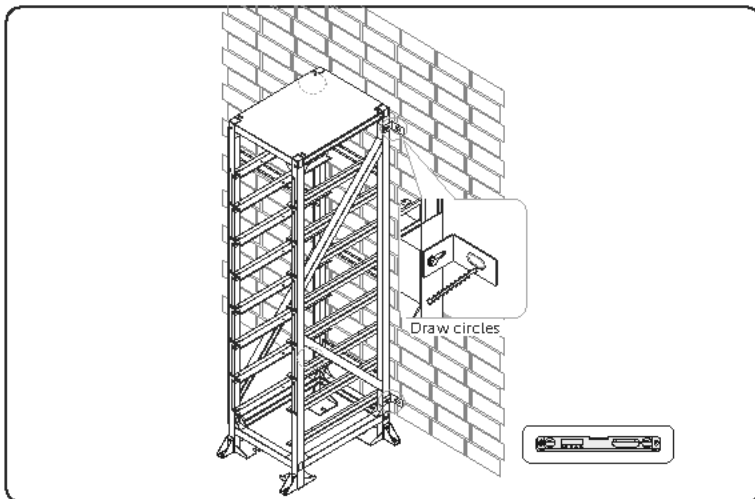

Figure 6-6 Drawing circles

NOTICE!

- Please ensure that L-shaped brackets on the rear side are flush with the wall before tightening screws.

Step 7: Remove the angle support and bracket, and then drill holes at the previously marked position (drill bit: $\varnothing 14$ mm; hole depth: 100 mm).

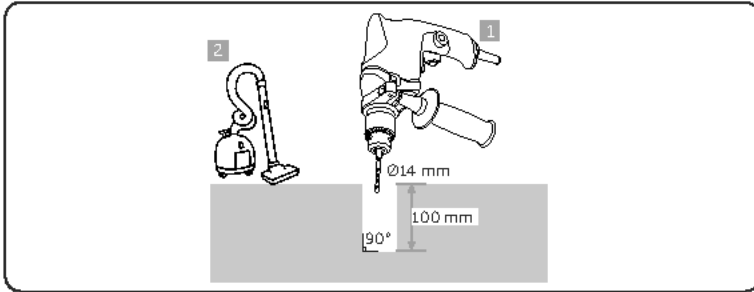

Figure 6-7 Drilling holes

Step 8: Remove the L-shaped bracket, and then drill holes at the previously marked position (drill bit: $\varnothing 16$ mm; hole depth: > 50 mm).

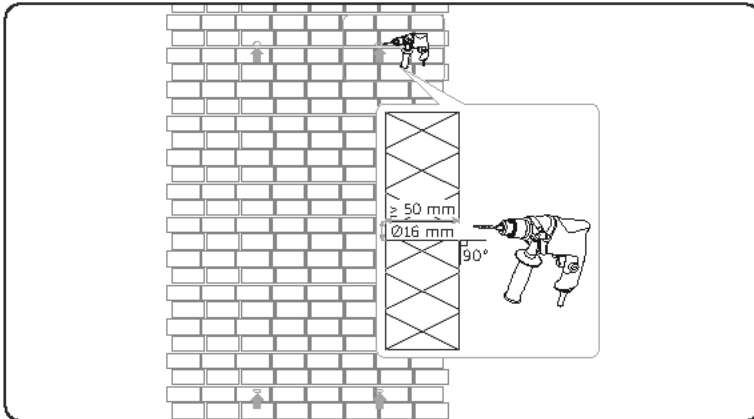

Figure 6-8 Drilling holes

NOTICE!

- Ladders are needed for drilling the holes on the wall.
- To prevent dust from falling on the bracket when drilling holes, users may use the package bag of the device or other materials to fully cover the bracket.
- Please clean the dust on the bracket, wall and foundation timely after drilling.

CAUTION!

- When using a ladder, it is prohibited to use a straight ladder. If electrical operations are involved, wooden ladders or insulated ladders must be selected.
- When in standby mode, the equipment shall not be used in the following scenarios:
 - a. Equipment directly related to life;
 - b. Sensitive precision instruments;
 - c. Electrical appliances that may malfunction due to power outages during use.

Step 9: Attach the angle support to the bracket by inserting and fully tightening M8 screws (Part J) (8 pcs) with a torque wrench (torque: 12 ± 1.2 N·m).

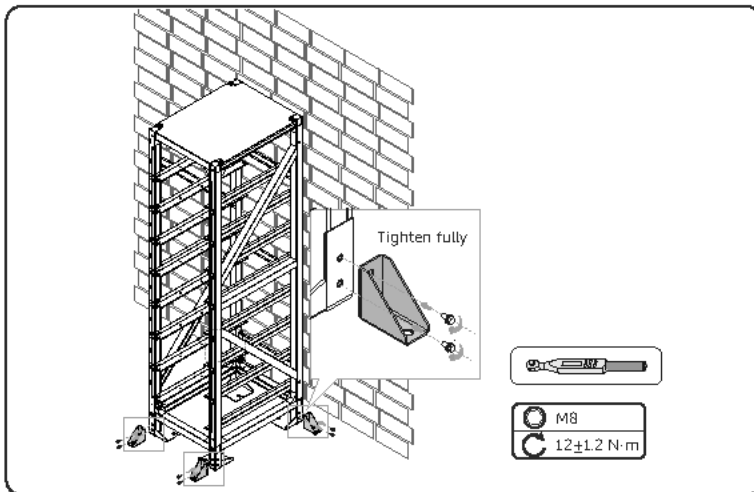

Figure 6-9 Tightening M8 screws

NOTICE!

- When tightening screws, ensure that the screw holes on the angle support align with the screw holes on the bracket and foundation.

Step 10: Use a rubber hammer to drive M10 expansion screws (Part I) (8 pcs) into the foundation screw holes, and then tighten them clockwise with a torque wrench (24 ± 2.4 N·m).

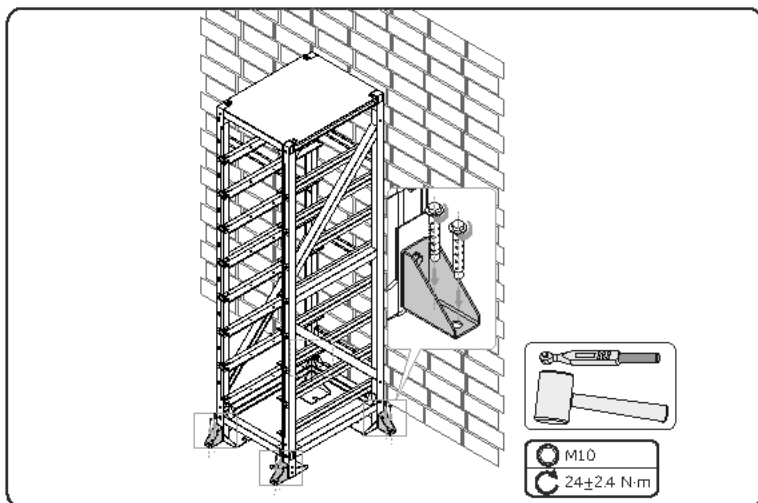

Figure 6-10 Tightening M10 expansion screws

Step 11: Use a rubber hammer to drive M10 expansion screws (Part I) (8 pcs) into the wall screw holes, and then tighten them clockwise with a torque wrench (24 ± 2.4 N·m). Fully tighten M8 screws (Part J) (8 pcs) (torque: 12 ± 1.2 N·m).

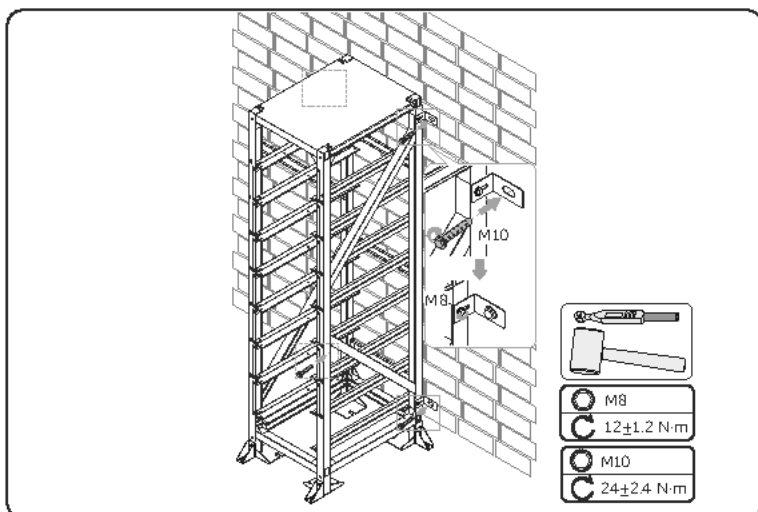

Figure 6-11 Tighten M8 and M10 screws

Step 12: Place the high-voltage box on the bottom layer of the bracket. Insert and tighten M8 screws (Part J) (x 4 pcs) with a torque wrench (torque: 12 ± 1.2 N·m) to secure the high-voltage box.

NOTICE!

- The high-voltage box weights 37.5 kg, and the battery pack weights 115 kg.

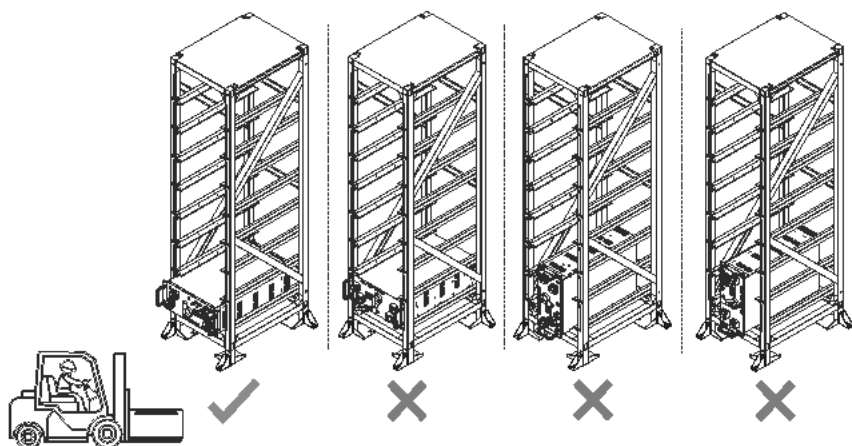

Figure 6-12 Forklift requirement

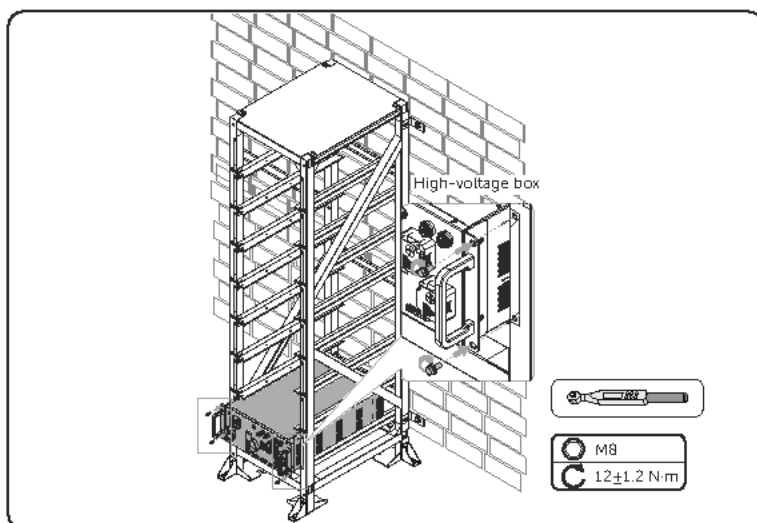

Figure 6-13 Securing the high-voltage box

Step 13: Attach the cable tray bracket (Part L) to the rack, and insert M5 screws (Part K) (2 pcs) and fully tighten them clockwise with a torque wrench (torque: 3 ± 0.3 N·m).

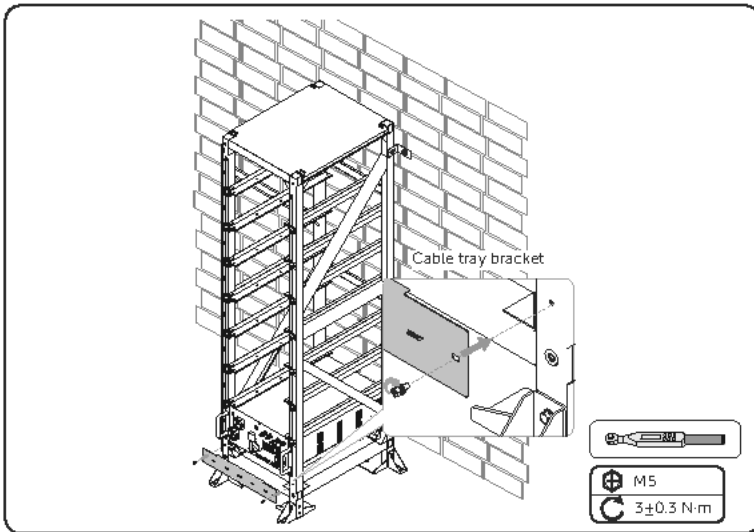

Figure 6-14 Attaching the cable tray bracket

Step 14: Place the battery pack on the layer above the high-voltage box. Insert and tighten M8 screws (Part J) (x 4 pcs) with a torque wrench (torque: 12 ± 1.2 N·m).

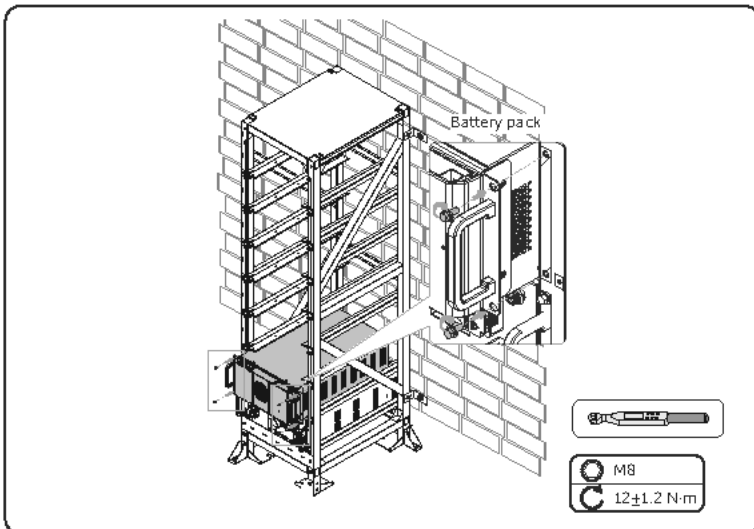

Figure 6-15 Securing the battery pack

Step 15: Place the second, third battery packs on the bracket.

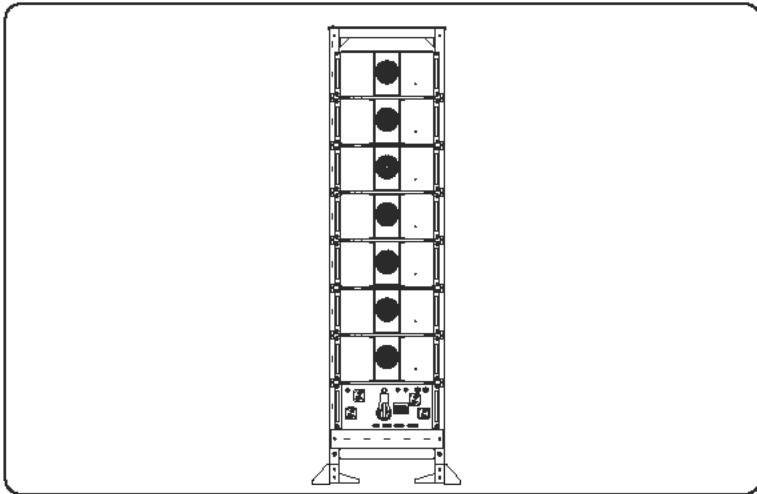

Figure 6-16 Well installed one bracket battery system

6.3 Dual bracket Battery System Installation

NOTICE!

- The battery system configuration of dual bracket system takes T-HR200.2 as an example.

- Step 1:** Attach left and right bracket frame (Part A and B) and bracing (Part C) (4 pcs). Firstly, secure M5 screws (Part K) into screw holes on both sides of bracket and bracing, but not fully tighten the screws on one side. Secondly, secure and fully tighten the screws on the other side. Finally, fully tighten all the screws with a torque wrench (torque: 3 ± 0.3 N·m).
- Step 2:** Attach left and right bracket frame (Part A and B) and beam (Part D) (3pcs). Firstly, secure M5 screws (Part K) into screw holes on both sides of bracket and beam, but not fully tighten the screws on one side. Secondly, secure and fully tighten the screws on the other side. Finally, fully tighten all the screws with a torque wrench (torque: 3 ± 0.3 N·m).

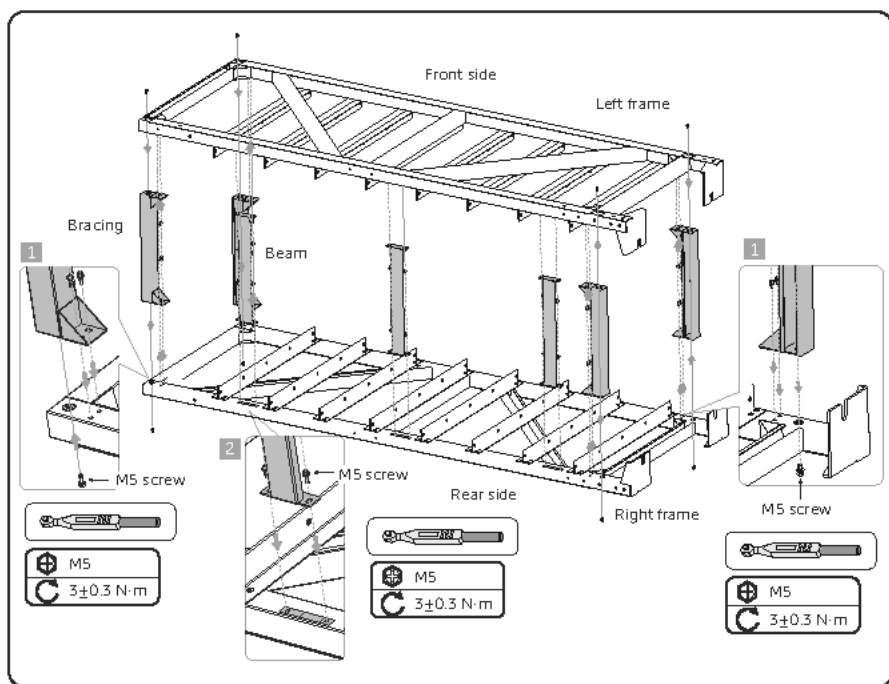

Figure 6-17 Assembling the bracket

Step 3: Attach the cover (Part F) by inserting and tightening M5 screws (Part K) (x 8 pcs) with a torque wrench (torque: 3 ± 0.3 N·m).

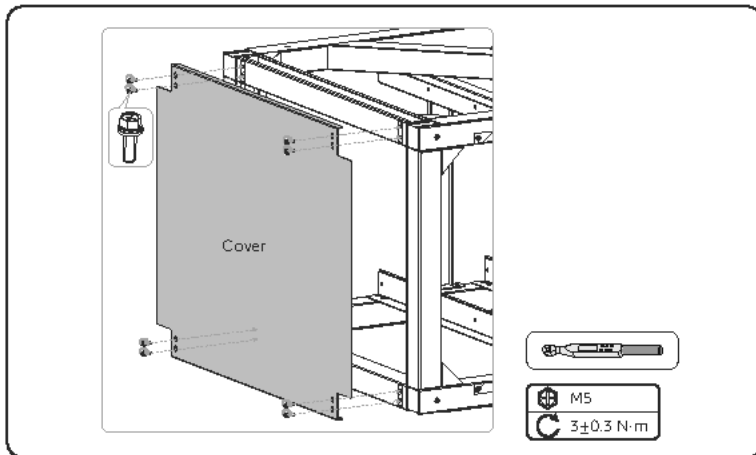

Figure 6-18 Attaching the cover

NOTICE!

- When attaching the cover, press the cover by hand to ensure that the holes can be correctly aligned and screws can be securely inserted into the holes on the bracket.

Step 4: Attaching the adjustable bracket (Part H) on both the front and rear sides of the brackets by inserting and tightening M8 screws (Part J) (8 pcs) with a torque wrench (torque: 12 ± 1.2 N·m). There are totalling four adjustable brackets for two racks.

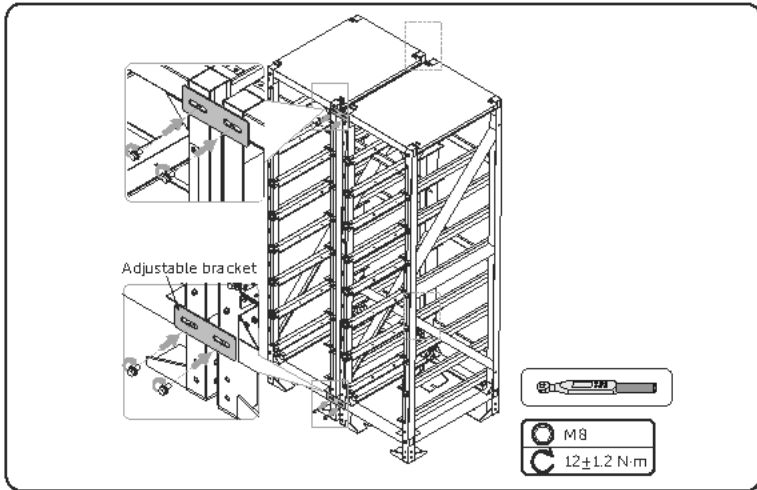

Figure 6-19 Attaching adjustable brackets

NOTICE!

- One side of the adjustable bracket has been fully coated with paint, and users need to secure screws on this side.

- Step 5:** After determining the installation position of the bracket, align the holes on the angle support (Part M) with the holes on the bracket, and secure M8 screws (Part J) (8 pcs), but do not fully tighten them.
 Draw circles on the bottom of angle supports.
 There are totalling six angle supports for two brackets. Only two angle supports need to be installed at the rear side of the brackets.

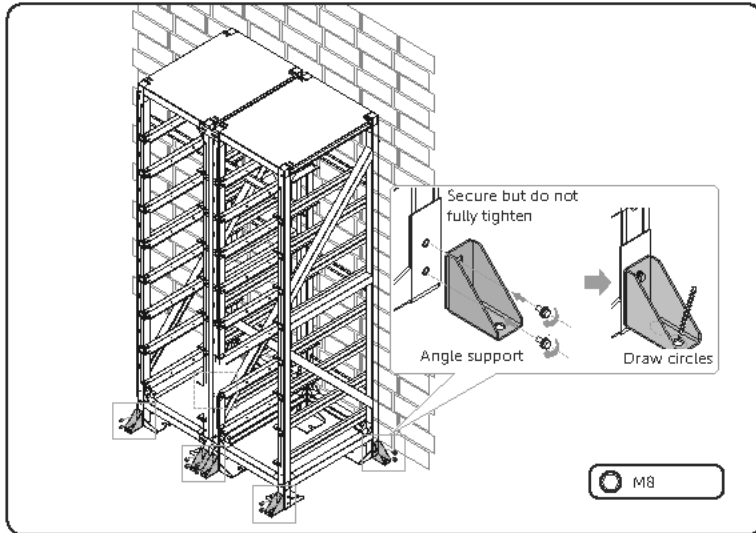

Figure 6-20 Drawing circles

NOTICE!

Installation options of angle supports:

- Two brackets (not installed against the wall): all angle supports can be left or right.
- Two brackets (installed against the wall):
 Option a: all angle supports can be left or right.
 Option b: two angle supports against the wall are left or right, and the remaining angle supports in the front side are forward.

If the bracket is not installed against the wall, please skip Step 6, 7, 9 and 12.

Step 6: Attach the L-shaped bracket (Part E) and insert M8 screws (Part J) (4 pcs), but do not fully tighten. There are totalling four L-shaped brackets for two brackets.

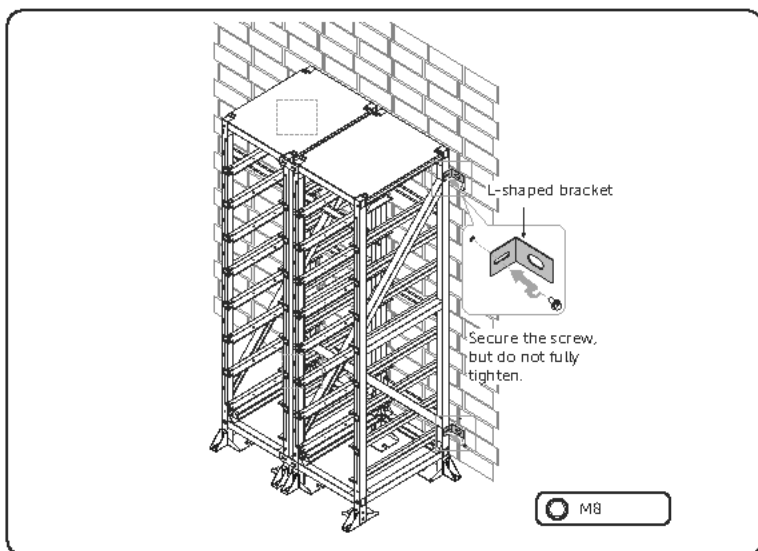

Figure 6-21 Securing M8 screws

Step 7: Place a spirit level to check whether L-shaped brackets are even. Draw circles along the inner ring of the holes on L-shaped brackets on the wall.

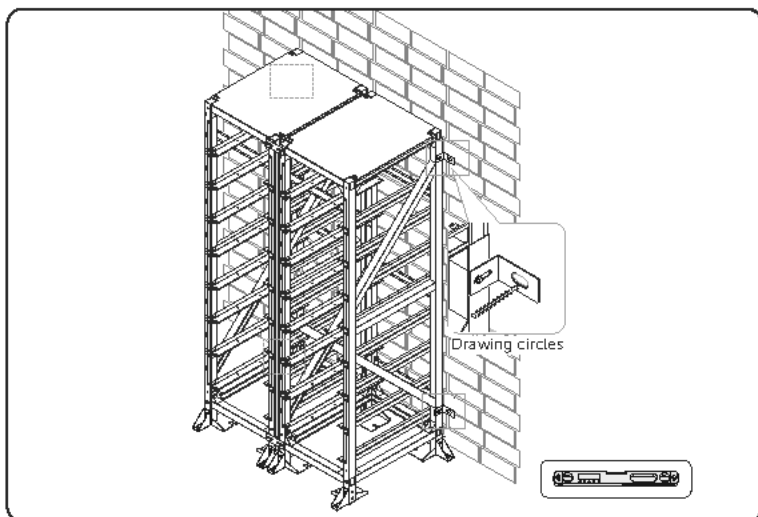

Figure 6-22 Drawing circles

NOTICE!

- Please ensure that L-shaped brackets on the rear side are flush with the wall before tightening screws.

Step 8: Remove the angle support and bracket, and then drill holes at the previously marked position (drill bit: $\varnothing 14$ mm; hole depth: 100 mm).

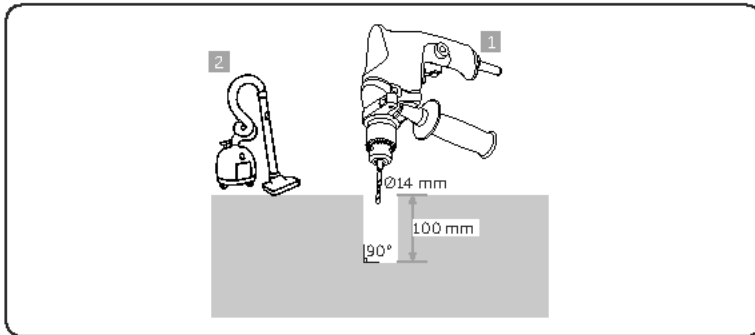

Figure 6-23 Drilling holes

Step 9: Remove the L-shaped bracket, and then drill holes at the previously marked position (drill bit: $\varnothing 16$ mm; hole depth: > 50 mm).

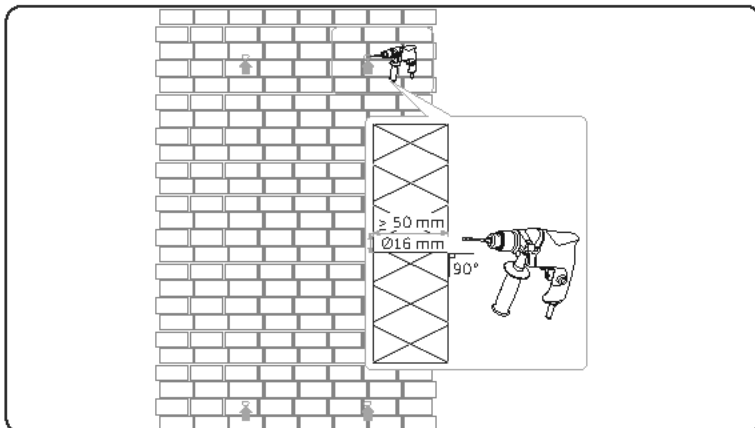

Figure 6-24 Drilling holes

NOTICE!

- Ladders are needed for drilling the holes on the wall.
- To prevent dust from falling on the bracket when drilling holes, users may use the package bag of the device or other materials to fully cover the bracket.
- Please clean the dust on the bracket, wall and foundation timely after drilling.

CAUTION!

- When using a ladder, it is prohibited to use a straight ladder. If electrical operations are involved, wooden ladders or insulated ladders must be selected.
- When in standby mode, the equipment shall not be used in the following scenarios:
 - a. Equipment directly related to life;
 - b. Sensitive precision instruments;
 - c. Electrical appliances that may malfunction due to power outages during use.

Step 10: Attach the angel support to the bracket by inserting and fully tightening M8 screws (Part J) (12 pcs) with a torque wrench (torque: 12 ± 1.2 N·m).

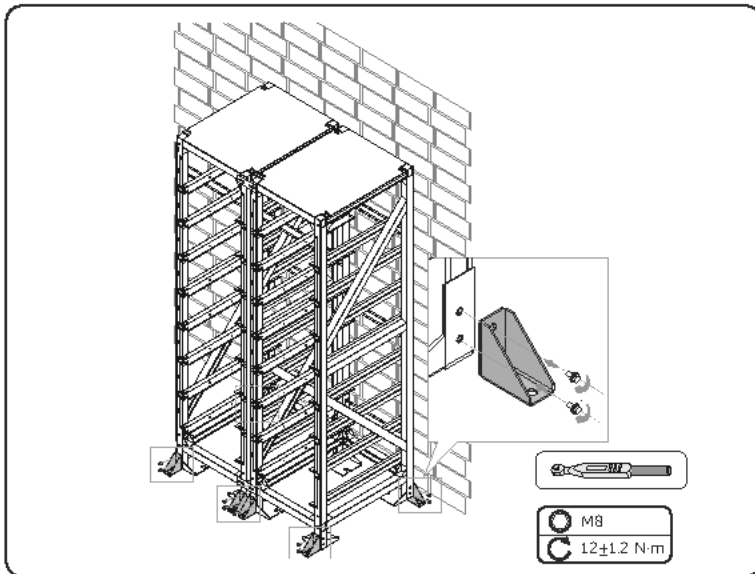

Figure 6-25 Tightening M8 screws

NOTICE!

- When tightening screws, ensure that the screw holes on the angle support align with the screw holes on the bracket and foundation.

Step 11: Use a rubber hammer to drive M10 expansion screws (Part I) (12 pcs) into the foundation screw holes, and then tighten them clockwise with a torque wrench (24 ± 2.4 N·m).

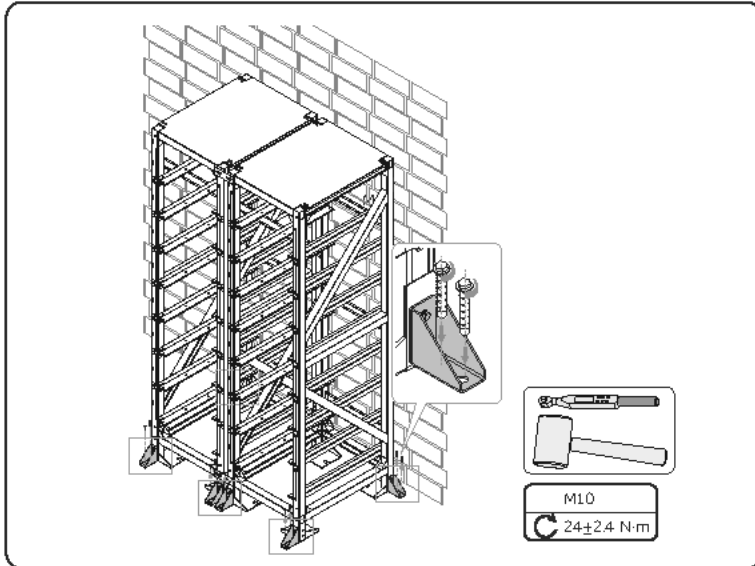

Figure 6-26 Tightening M10 expansion screws

Step 12: Use a rubber hammer to drive M10 expansion screws (Part I) (8 pcs) into the wall screw holes, and then tighten them clockwise with a torque wrench (24 ± 2.4 N·m). Fully tighten M8 screws (Part J) (8 pcs) (torque: 12 ± 1.2 N·m).

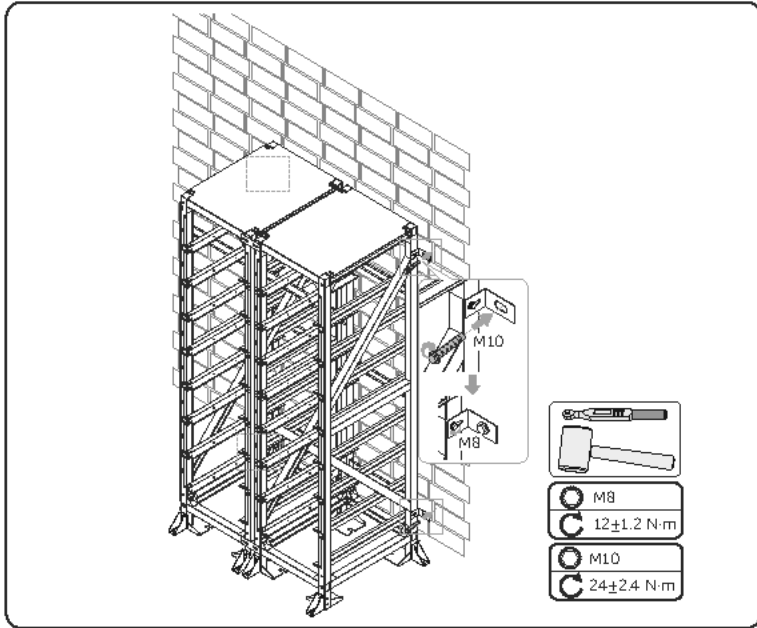

Figure 6-27 Tighten M8 and M10 screws

Step 13: Place the high-voltage box on the bottom layer of the right bracket. Insert and tighten M8 screws (Part J) (4 pcs) with a torque wrench (torque: 12 ± 1.2 N·m) to secure the high-voltage box.

NOTICE!

- The high-voltage box weights 37.5 kg, and the battery pack weights 115 kg.

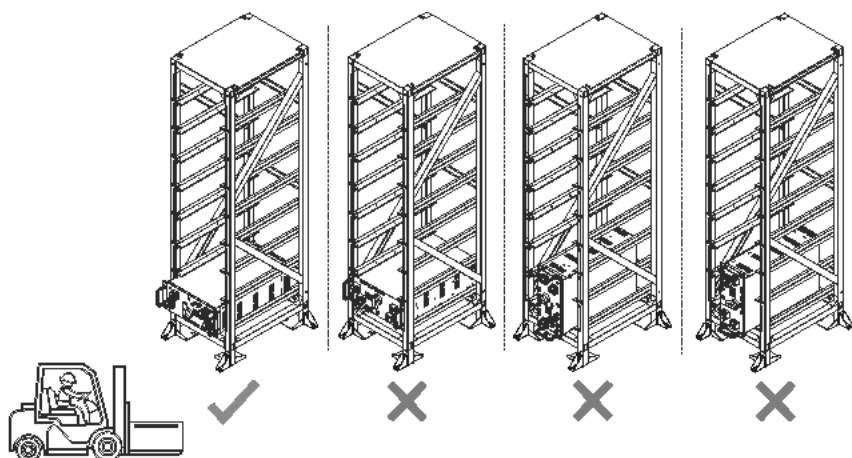

Figure 6-28 Forklift requirement

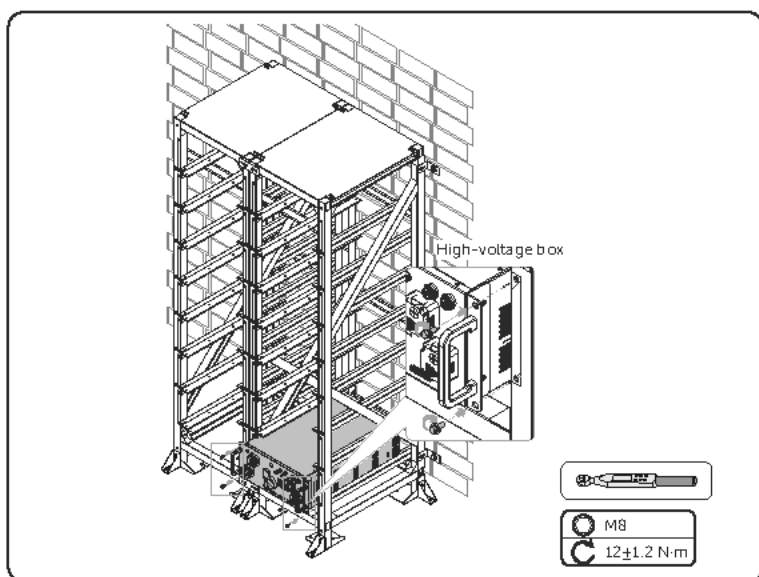

Figure 6-29 Securing the high-voltage box

Step 14: Attach the cable tray bracket (Part L) to the bracket, and insert M5 screws (Part K) (2 pcs) and fully tighten them clockwise with a torque wrench (torque: 3 ± 0.3 N·m).

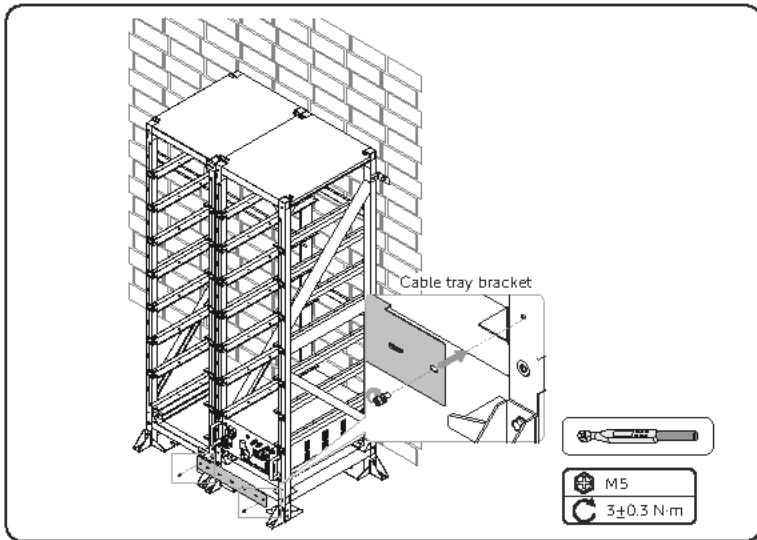

Figure 6-30 Attaching the cable tray bracket

Step 15: Place the battery pack on the layer above the high-voltage box. Insert and tighten M8 screws (Part J) (× 4 pcs) with a torque wrench (torque: 12 ± 1.2 N·m).

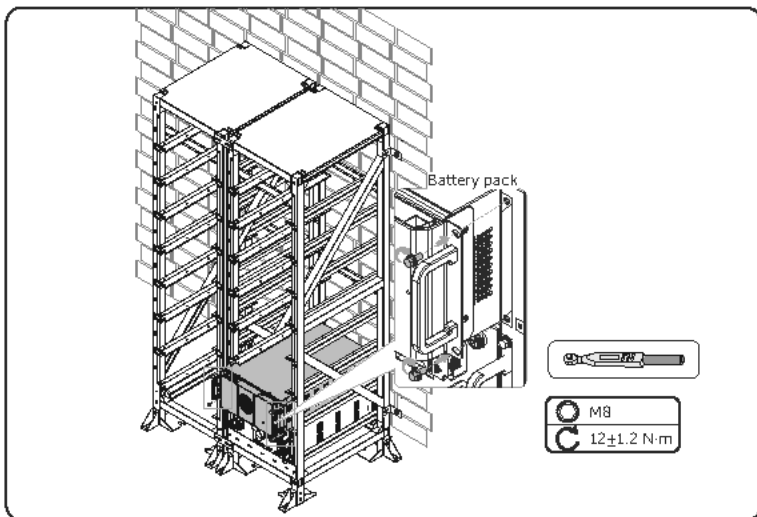

Figure 6-31 Securing the battery pack

Step 16: Place the second, third battery packs on the bracket.

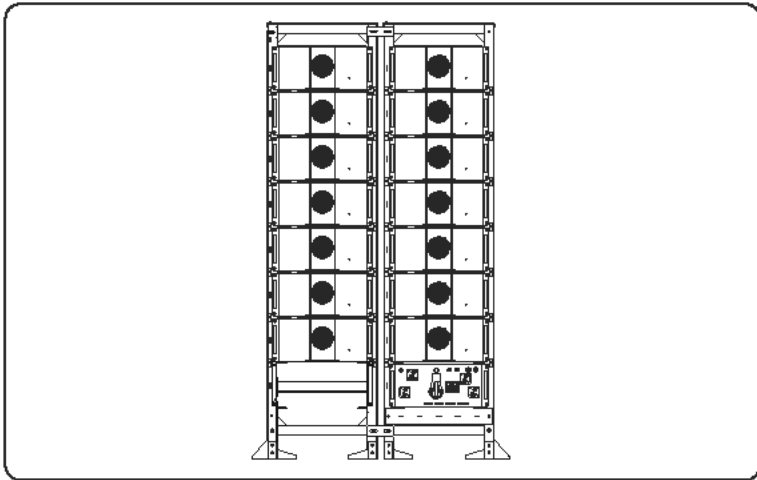

Figure 6-32 Well installed dual bracket battery system

6.4 Inverter Installation

⚠ WARNING!

- Only the qualified personnel can perform the mechanical installation following the local standards and requirements.
- Check the existing power cables or other piping in the wall to prevent electric shock or other damage.

⚠ CAUTION!

- Always be aware of the weight of the inverter. Personal injuries may result if the inverter is lifted improperly or dropped while being transported or mounted.
- Use insulated tools when installing the inverter. Personal protective equipment must be worn during installation and maintenance.

NOTICE!

- Install the inverter at a maximum back tilt of 5 degrees and avoid forward tilted, side tilted, or upside down.

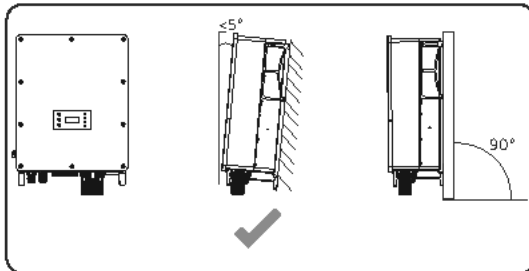

Figure 6-33 Correct installation

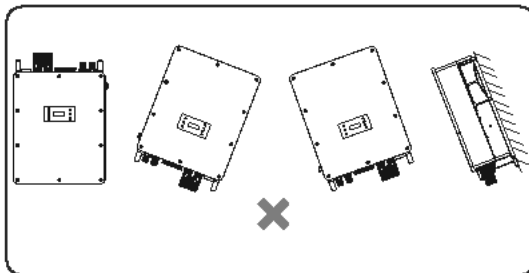

Figure 6-34 Incorrect installation

6.4.1 Installation Dimensions

Check the dimensions of the wall mounting bracket before mounting and reserve sufficient space for heat dissipation and installation of the whole system.

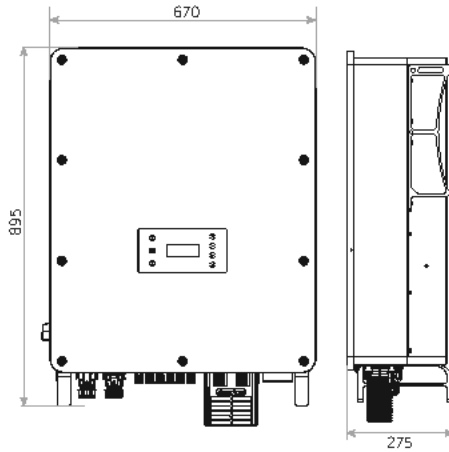

Figure 6-35 Dimensions 1 (unit: mm)

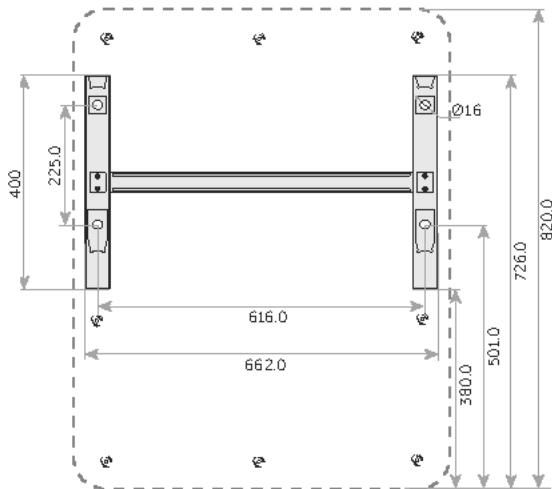

Figure 6-36 Dimensions 2 (unit: mm)

6.5 Installation Procedures

The device can choose to be installed on the wall or on the battery cabinet.

6.5.1 Wall Mounting Procedures

Step 1: Mark one of the position of drill holes at least 175 cm perpendicular to the ground. Align the mounting bracket (Part A5) horizontally on the wall and mark the rest positions of the drill holes in sequence.

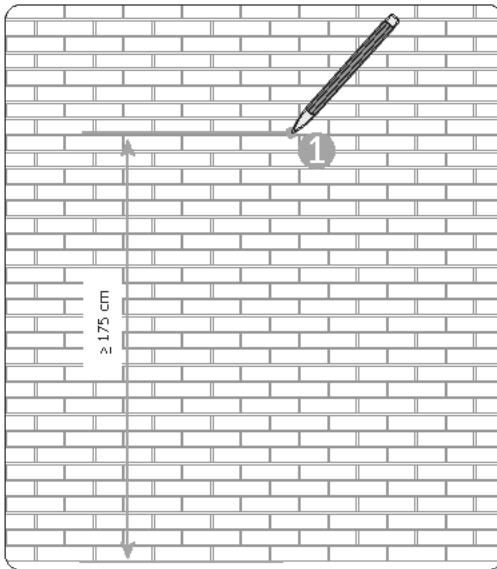

Figure 6-37 Marking the first hole

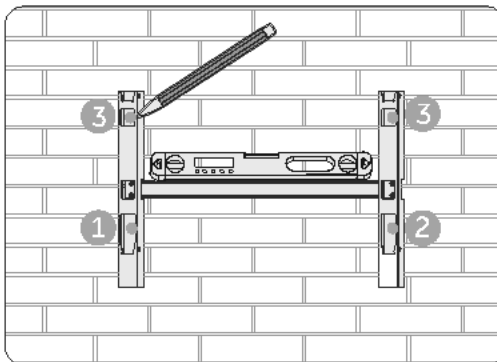

Figure 6-38 Marking the rest holes

NOTICE!

- Take the height of the battery into account when mounting the mounting bracket.
- Observe the bubble of spirit level and adjust the mounting bracket until the bubble stays in the middle.

Step 2: Set the mounting bracket aside and drill holes with $\varnothing 15$ mm drill bit. The depth of the holes should be deeper than 100 mm.

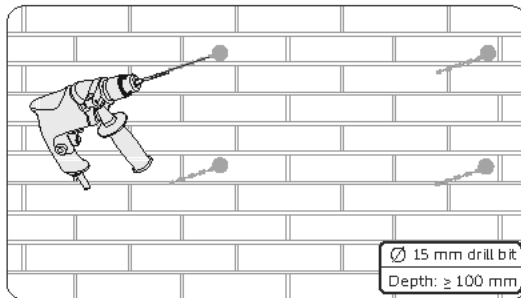

Figure 6-39 Drilling holes

Step 3: Attach the mounting bracket on the wall again. Knock the expansion screws (Part K5) through the bracket and into the holes and secure it to the wall by torque wrench. (Torque: 24 N·m)

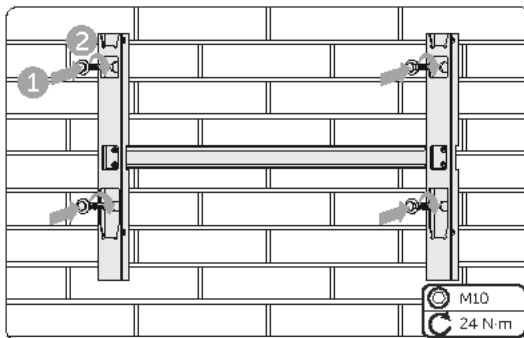

Figure 6-40 Securing the mounting bracket

Step 4: Open the anti-static bag and take out the machine.

NOTICE!

- If the inverter is temporarily needed to be placed on the ground, use foam or other protective materials to prevent any damage to the inverter.

Step 5: Remove the carton, loosen and pull out the M10 screws on the sides of the inverter with a flat-head screwdriver. Tighten the two eye bolts (Part L5) on the two sides of the inverter and tie them with a sling. Lift up the inverter with a crane and hang the device on the mounting bracket. The keyways of the inverter must be hooked into the buckles of the mounting bracket.

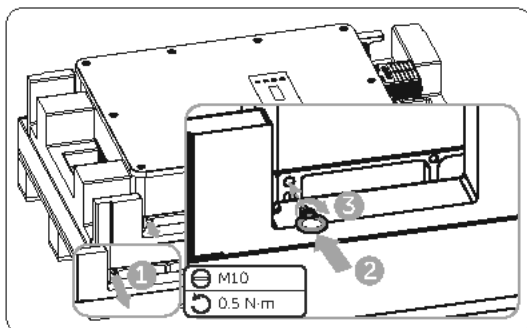

Figure 6-41 Installing the eye bolts

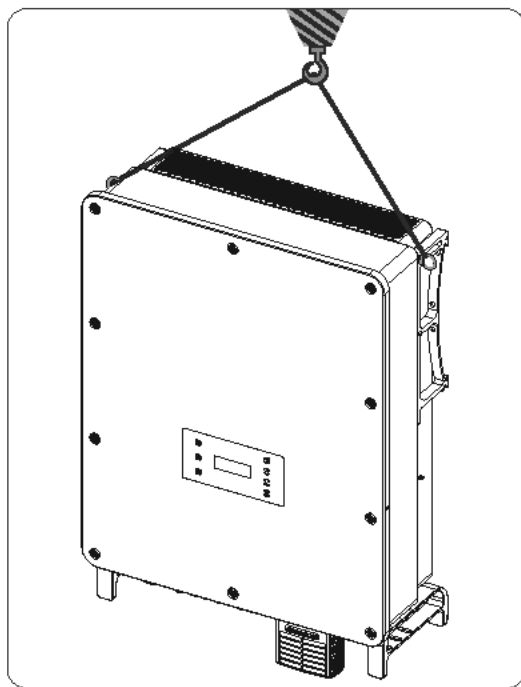

Figure 6-42 Hanging the inverter

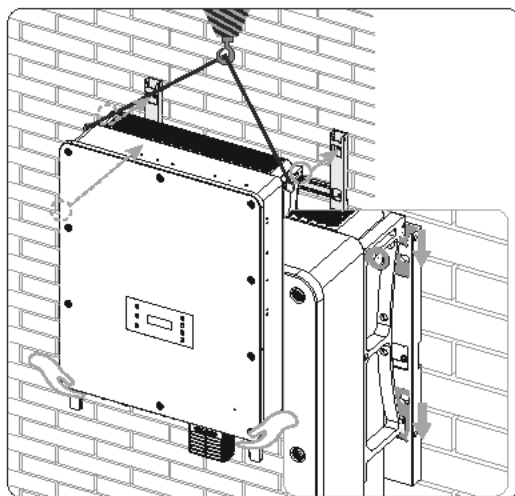

Figure 6-43 Hooking the inverter on the bracket

NOTICE!

- When the inverter is lifted up from the carton or the inverter is close to the mounting bracket, use hands to adjust the inverter position to prevent any damage to the inverter.
- Ladders will be helpful for installers to stand in a proper position and adjust the inverter position.

Step 6: Remove the eye bolts when the inverter is hooked on the mounting bracket and tighten the M10 screws with a flat-head screwdriver.

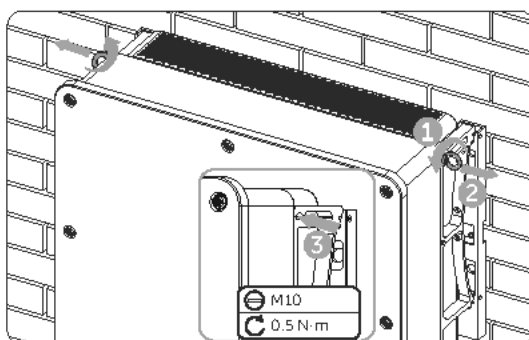

Figure 6-44 Removing the eye bolts

NOTICE!

- After removing the eye bolts from the inverter, keep them in a safe place. They are needed when the inverter is relocated or disassembled.

Step 7: Secure the inverter to the wall mounting bracket with M5 screws (Part B5). (Torque: 2 ± 0.2 N·m)

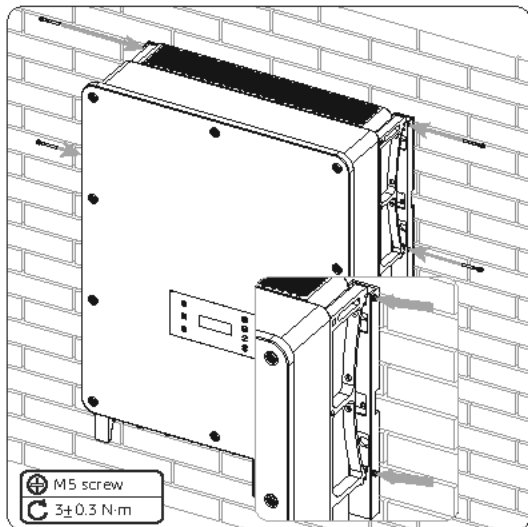

Figure 6-45 Securing the inverter

7 Electrical Connection

7.1 One bracket Battery System Wiring

Cables between the battery packs, high voltage box and inverter, as shown in the following figure.

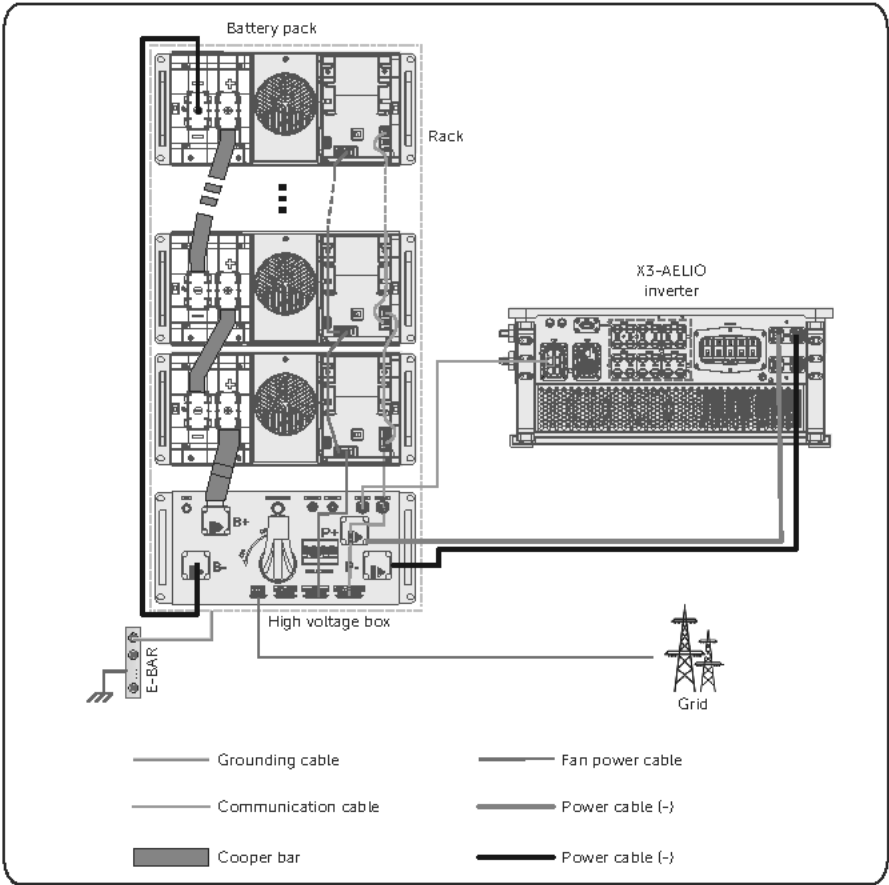

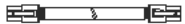

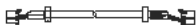
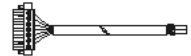

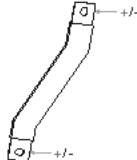
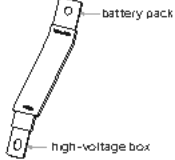





Figure 7-1 One bracket wiring diagram

Table 7-1 Cable information

Cable	Length	Description
PE connection		
Grounding cable (Part F1)		1000 mm Bracket → grounding plate
Fan power cable connection		
Fan power cable (Part B2)		300 mm FAN port of battery pack → FAN port of another battery pack
Fan power cable (Part G1)		2300 mm FAN port of battery pack → FAN port of high-voltage box
Fan power cable (Part C1)		2000 mm AC input port of high-voltage box → Grid
Communication connection		
Communication cable (Part C2)		300 mm COM port of battery pack → COM port of another battery pack
Communication cable (Part A1)		550 mm COM port of battery pack → COM port of high-voltage box
Communication cable (Part B1)		2000 mm PCS COM port of high-voltage box → COM1 port of inverter
Copper bar connection		
Copper bar (Part A2)		/ + or - terminal of battery packs → + or - terminal of another battery packs
Copper bar (Part J1)		/ + terminal of battery pack → B+ port of high-voltage box
Power cable connection		
Power cable (-) (Part H1)		2300 mm - terminal of the top battery pack → B- port of high-voltage box
Power cable (+) (Part D1)		2300 mm P+ port of high-voltage box → BAT1+ and BAT2+ port of inverter
Power cable (-) (Part E1)		2300 mm P- port of high-voltage box → BAT1- and BAT2- port of inverter

7.1.1 PE Connection

- Step 1:** Insert M8 screws (Part J) into the ring terminal at one end of the PE cable and bracket, and then tighten it (torque: 12 ± 1.2 N·m). There are two grounding ports (a and b) at the bottom of the bracket, and users need to choose one of them to connect.

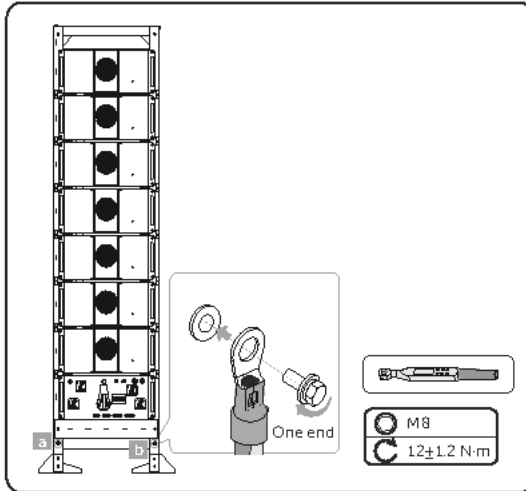

Figure 7-2 Tightening M8 screws

- Step 2:** Insert M8 screws (Part J) into the ring terminal at the other end of the PE cable and grounding plate, and then tighten it (torque: 12 ± 1.2 N·m).

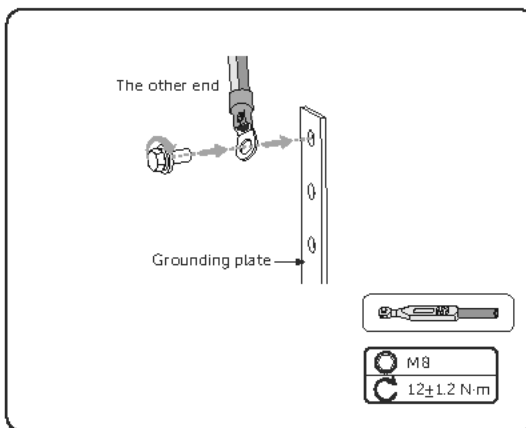

Figure 7-3 Tightening M8 screws

7.1.2 Fan Power Cable Connection

Step 1: Push the left and right covers of battery pack.

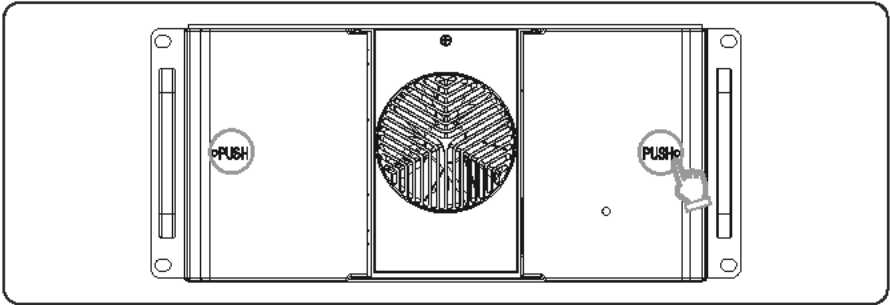

Figure 7-4 Pushing covers

Step 2: Connect and fix the fan power cable (Part B2) between battery packs.

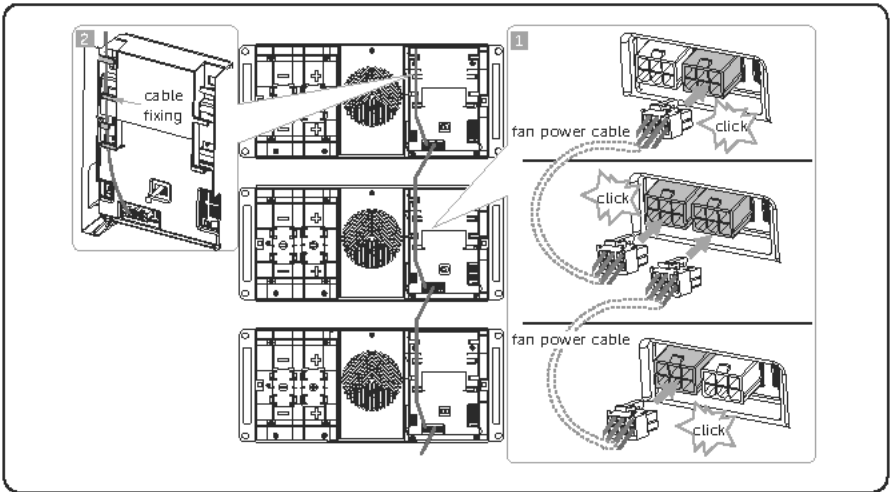

Figure 7-5 Fan power cable connection

Step 3: Connect the fan power cable (Part G1) between battery pack and high-voltage box. Thread the cables through the cable tie mount on the cable tray bracket (Part L).

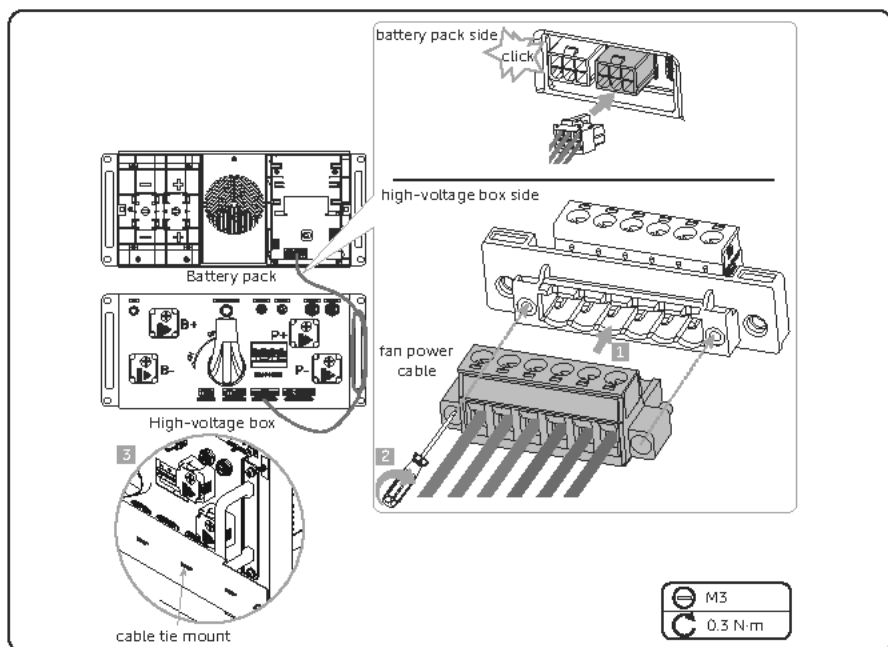

Figure 7-6 Fan power cable connection

Step 4: Connect the fan power cable (Part C1) between the high-voltage box and socket.

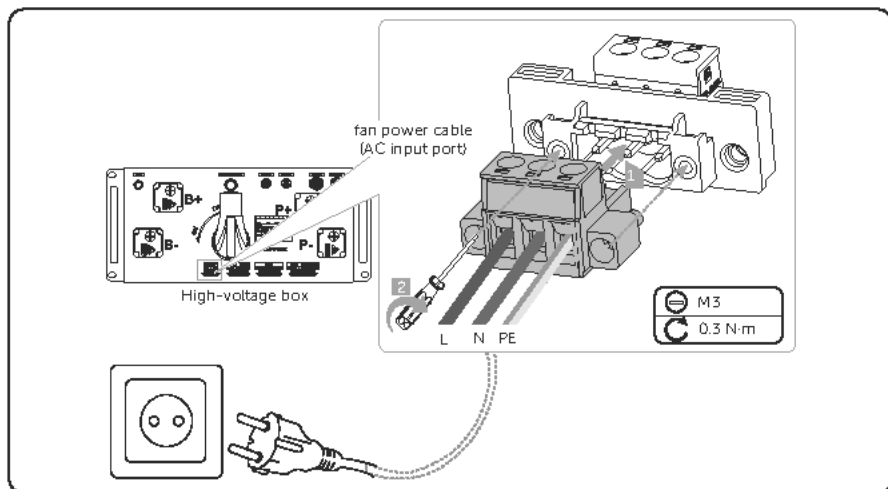

Figure 7-7 Fan power cable connection

7.1.3 Communication Connection

Step 1: Connect and fix the communication cable (Part C2) between battery packs.

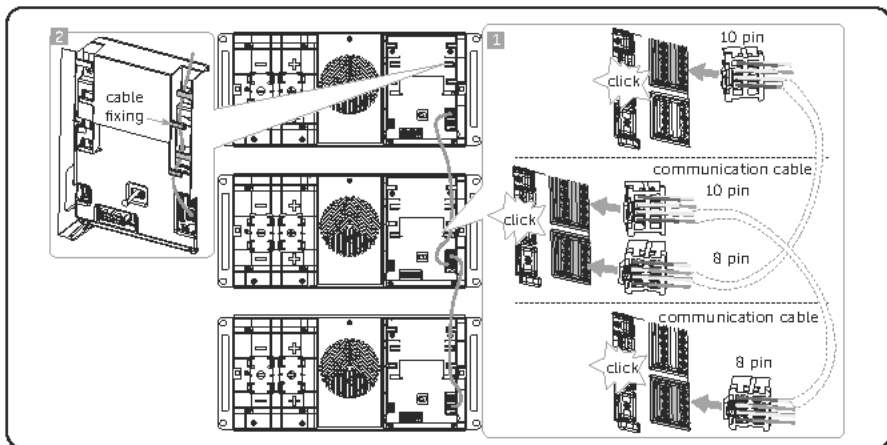

Figure 7-8 Communication cable connection

Step 2: Connect the communication cable (Part A1) between battery pack and high-voltage box. Thread the cables through the cable tie mount on the cable tray bracket (Part L).

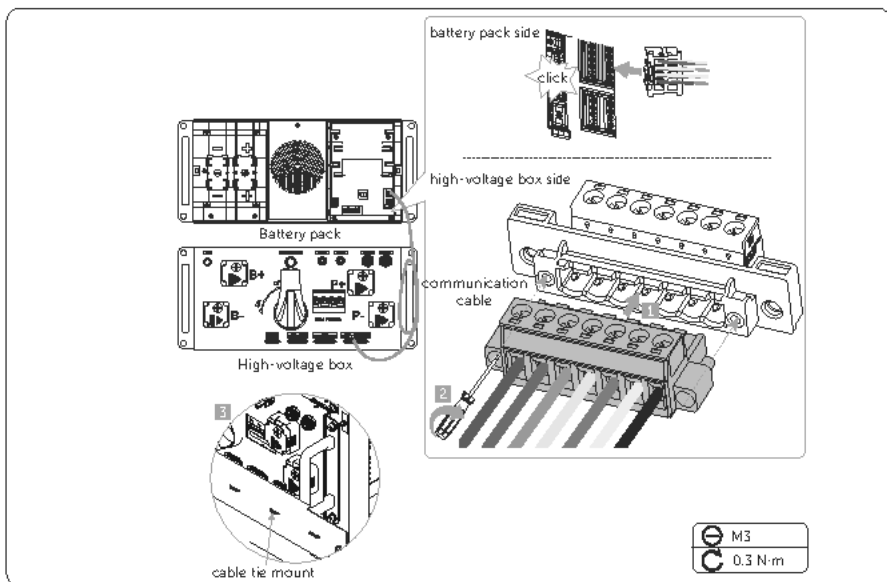

Figure 7-9 Communication cable connection

Step 3: Connect the communication cable (Part B1) between the high-voltage box and inverter.

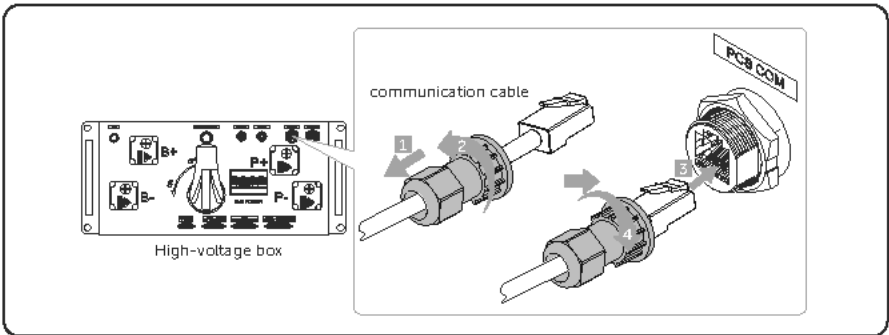

Figure 7-10 Communication cable connection

NOTICE!

- For inverter side wiring, please refer to "BMS communication connection".

Step 4: Insert the terminal resistance (Part I1) into the communication port (8 pin) in the top battery pack.

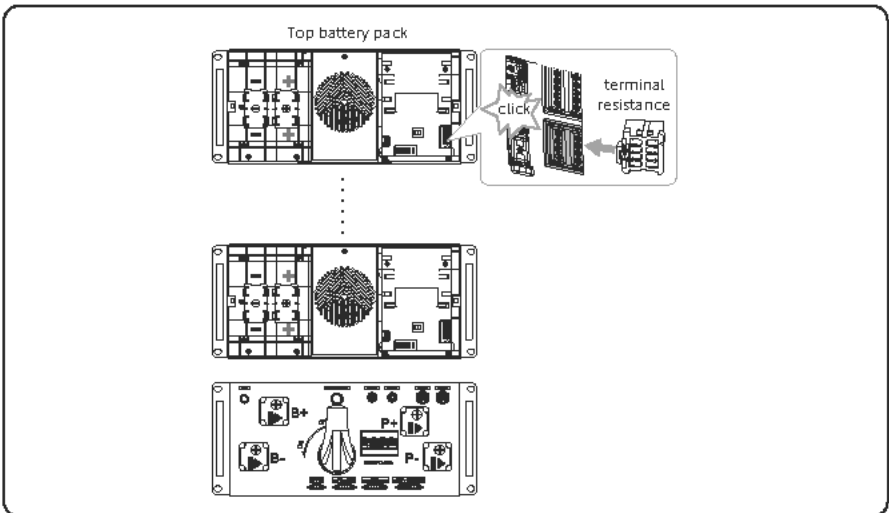

Figure 7-11 Terminal resistance connection

7.1.4 Copper Bar Connection



WARNING!

- To prevent a short circuit and avoid losing the cover, please strictly follow the steps below: **remove the cover on the negative(-) port** → **connect the copper bar/power cable to the negative(-) port** → **recover the cover to the negative(-) port** → **remove the cover on the positive(+) port** → **connect the copper bar to the positive(+) port** → **recover the cover to the positive(+) port**.

The order of copper bar connection is shown as follows:

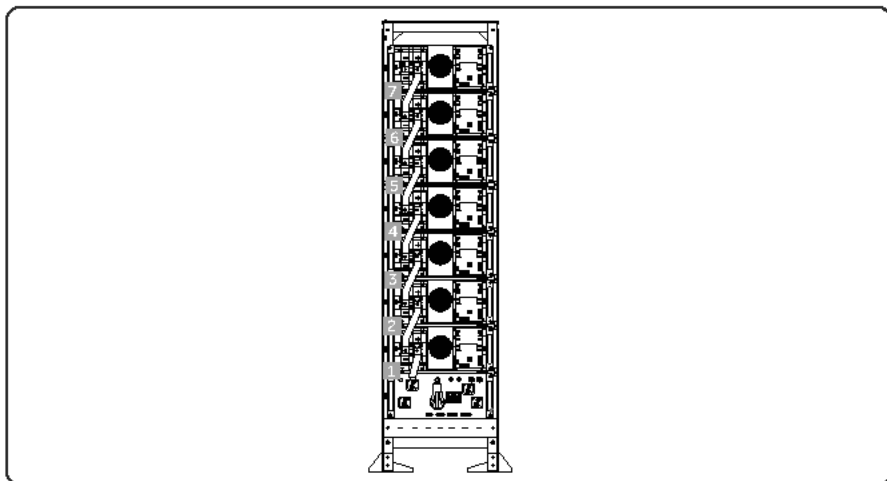

Figure 7-12 Copper bar connection sequence

Connection procedure

- Step 1:** Connect copper bar between battery packs.
- Remove the cover of positive or negative port of battery pack.
 - Secure the copper bar (Part A2) and pin by inserting and tightening M8 nut (Part D2) with a torque wrench (torque: 7~8 N·m).
 - Reinstall the terminal cover.

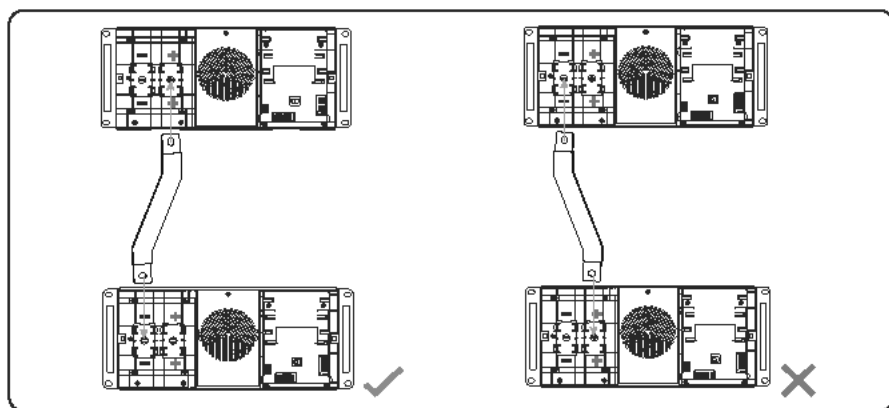

Figure 7-13 Copper bar connection

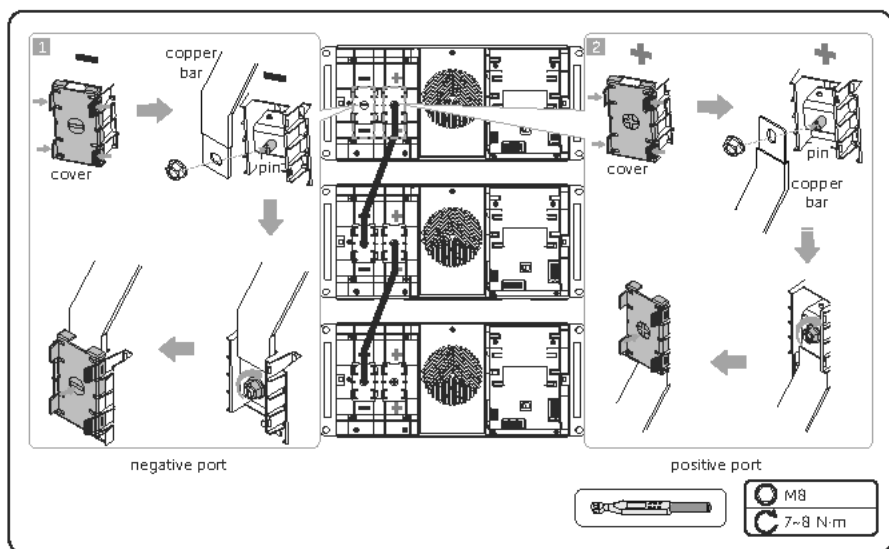

Figure 7-14 Copper bar connection

Step 2: Connect copper bar between battery pack and high-voltage box.

- Remove the cover of positive port of battery pack.
- Align the screw hole of copper bar with pin. Insert and tighten M8 nut to secure copper bar (Part J1) with a torque wrench (torque: 7~8 N·m).
- Reinstall the cover.
- Remove the cover of B+ port of high-voltage box.

- e. Unscrew M8 screw and insert copper bar into BAT+ port.
- f. Insert and tighten M8 screw to secure copper bar with a torque wrench (torque: 7~8 N·m).
- g. Reinstall the cover.

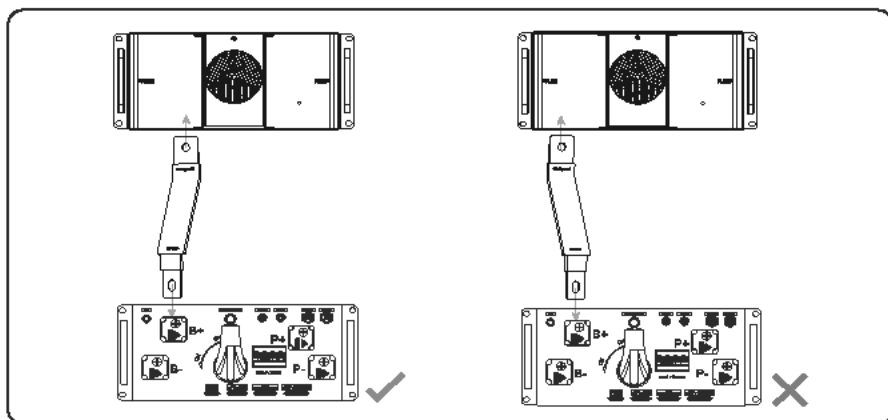

Figure 7-15 Copper bar connection

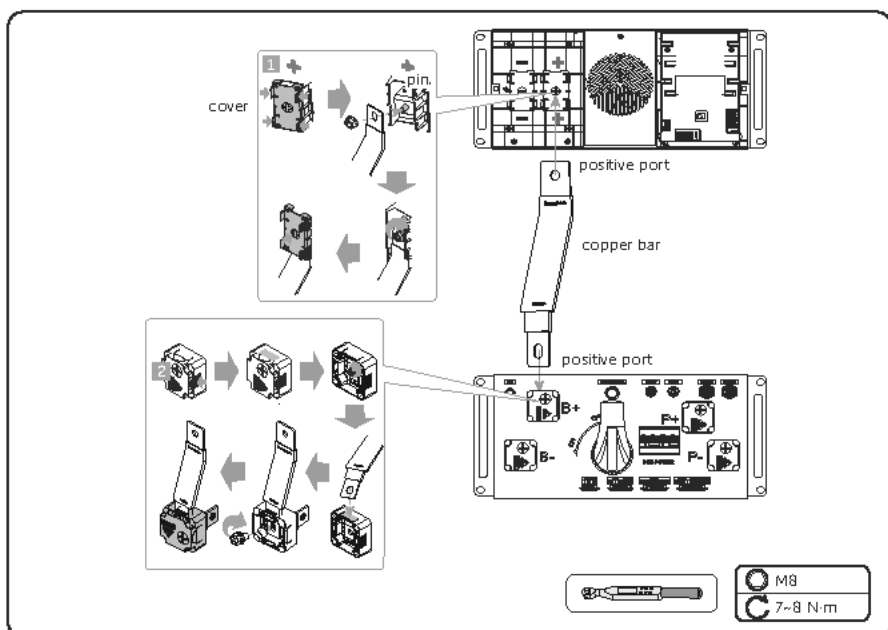

Figure 7-16 Copper bar connection

7.1.5 Power Cable Connection

- Step 1:** Connect negative power cable (Part H1) between high-voltage box and top battery pack.
- Remove the cover of negative port of top battery pack.
 - Align the terminal of negative power cable with pin. Insert and tighten M8 nut to secure negative power cable with a torque wrench (torque: 7~8 N·m).
 - Reinstall the cover.
 - Remove the cover of B- port of high-voltage box.
 - Unscrew M8 screw and insert the terminal of negative power cable into B- port. Insert and tighten M8 screw to secure negative power cable with a torque wrench (torque: 7~8 N·m).
 - Reinstall the cover.
 - Thread the cables through the cable tie mount on the cable tray bracket (Part L).

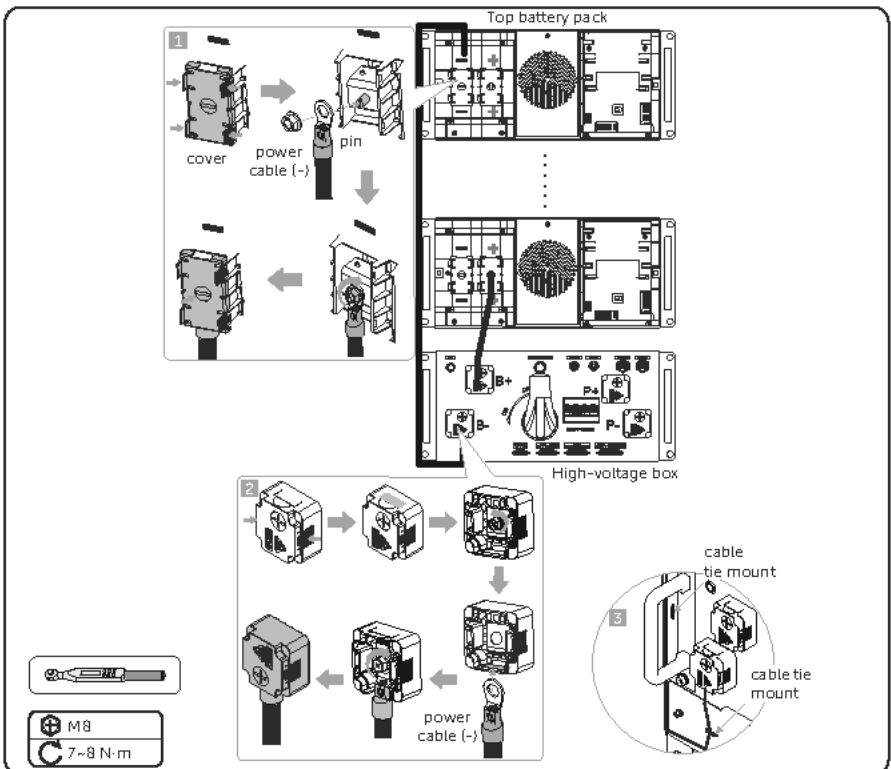

Figure 7-17 Power cable connection

- Step 2:** Connect the positive and negative power cables (Part D1 and E1) between the high-voltage box and inverter.
- Remove the cover of P+ and P- ports of high-voltage box.
 - Unscrew M8 screw and insert the terminal of negative and positive power cables into P+ and P- ports.
 - Insert and tighten M8 screw with a torque wrench (torque: 7~8 N·m). Reinstall the cover.
 - Thread the cables through the cable tie mount on the cable tray bracket (Part L).

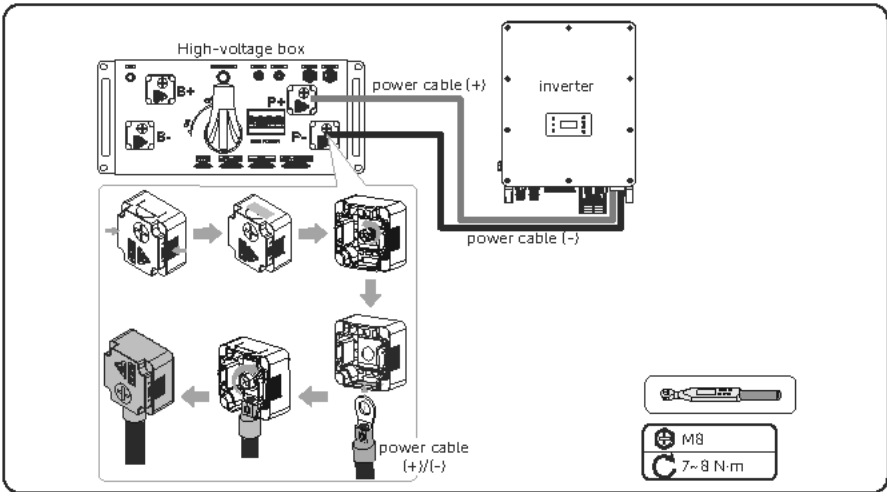

Figure 7-18 Power cables connection

NOTICE!

- For inverter side wiring, please refer to "7.3.5 Battery Power Cable Connection".

Step 3: Check if the wiring is correct according to the wiring diagram below.

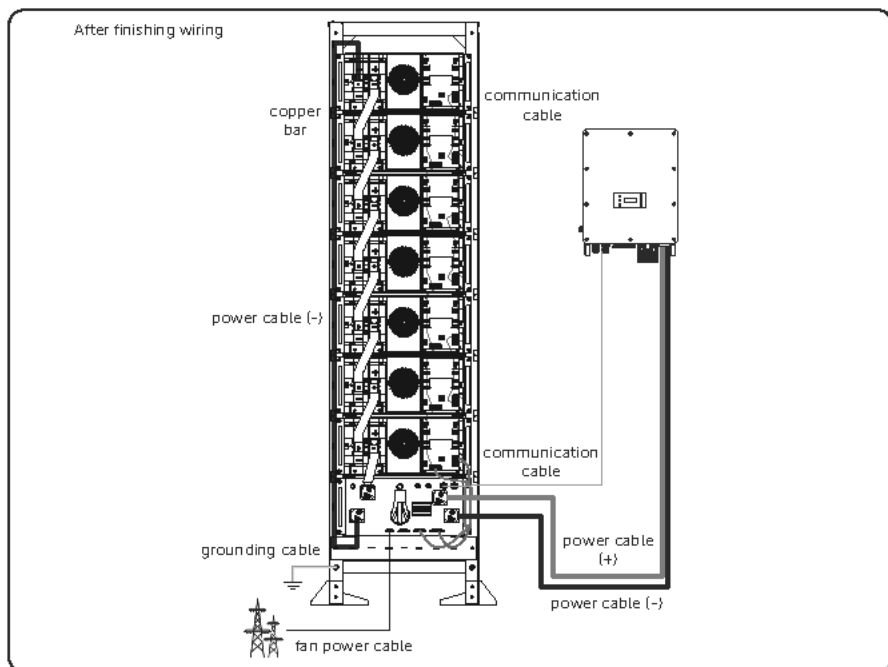

Figure 7-19 Wiring diagram (one bracket)

Step 4: Close battery pack covers.

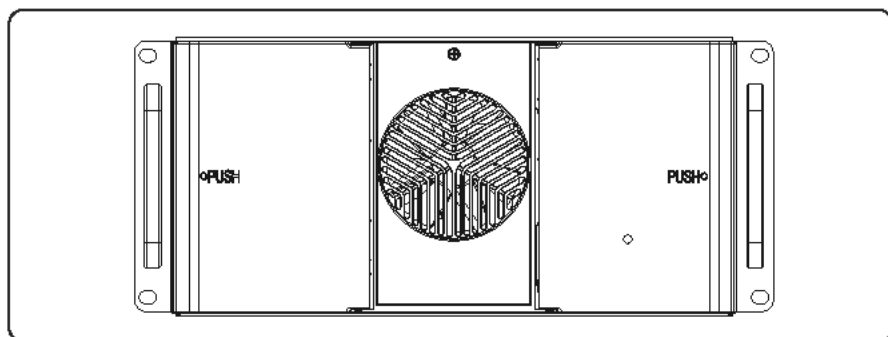

Figure 7-20 Closing battery pack cover

Step 5: Attach protection bar (Part G) (7 pcs) by inserting and tightening M5 screws (Part K) (14 pcs) with a torque wrench (Torque: 3 ± 0.3 N·m).

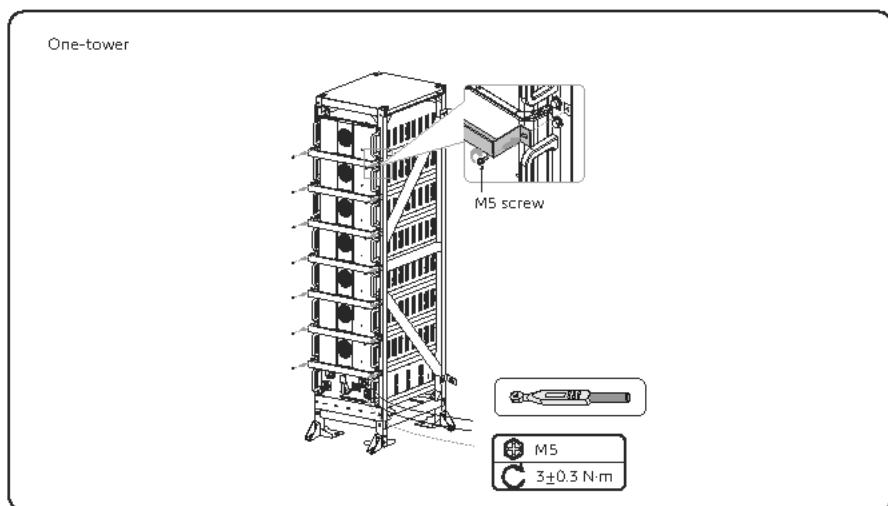

Figure 7-21 Attaching protection bar

7.2 Dual bracket Battery System Connection

NOTICE!

- The battery system configuration of dual bracket system takes T-HR200.2 as an example.

Cables between the battery packs, high voltage box and inverter, as shown in the following figure.

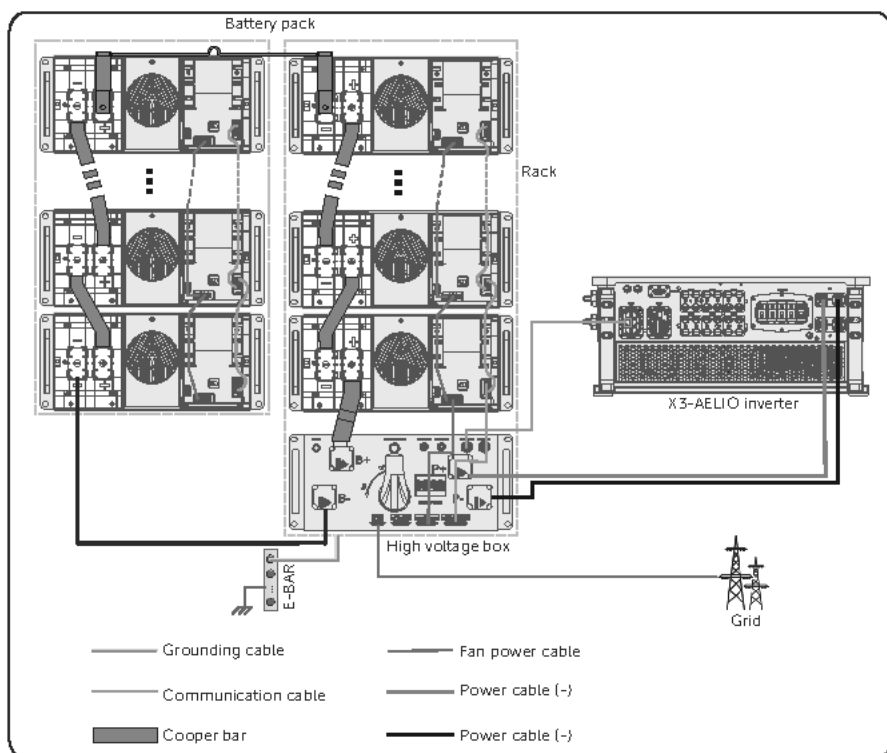
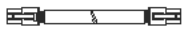
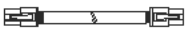

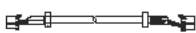

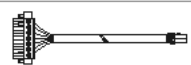

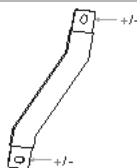
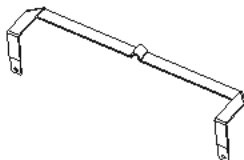
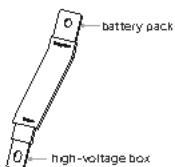





Figure 7-22 Wiring diagram

Table 7-2 Cable information

Cable	Length	Description
PE connection		
Grounding cable (Part F1)	1000 mm	Bracket → grounding plate
Fan power cable connection		

Electrical Connection

	Cable	Length	Description
Fan power cable (Part B2)		300 mm	FAN port of battery pack → FAN port of another battery pack
Fan power cable (Part B3)		1100 mm	FAN port of the top battery pack → FAN port of another top battery pack
Fan power cable (Part G1)		2300 mm	FAN port of battery pack → FAN port of high-voltage box
Fan power cable (Part C1)		2000 mm	AC input port of high-voltage box → Grid
Communication connection			
Communication cable (Part C2)		300 mm	COM port of battery pack → COM port of another battery pack
Communication cable (Part C3)		1100 mm	COM port of the top battery pack → COM port of another top battery pack
Communication cable (Part A1)		550 mm	COM port of battery pack → COM port of high-voltage box
Communication cable (Part B1)		2000 mm	PCS COM port of high-voltage box → COM1 port of inverter
Copper bar connection			
Copper bar (Part A2)		/	+ or - terminal of battery packs → + or - terminal of another battery packs
Copper bar (Part A3)		/	+ terminal of the top battery pack → - terminal of another top battery pack
Copper bar (Part J1)		/	+ terminal of battery pack → B+ port of high-voltage box
Power cable connection			
Power cable (-) (Part H1)		2300 mm	- terminal of the top battery pack → B- port of high-voltage box
Power cable (+) (Part D1)		2300 mm	P+ port of high-voltage box → BAT1+ and BAT2+ port of inverter
Power cable (-) (Part E1)		2300 mm	P- port of high-voltage box → BAT1- and BAT2- port of inverter

7.2.1 PE Connection

- Step 1:** Insert M8 screws (Part J) into the ring terminal at one end of the PE cable and bracket, and then tighten it (torque: 12 ± 1.2 N·m). There are two grounding ports (a and b) at the bottom of the bracket, and users need to choose one of them to connect.

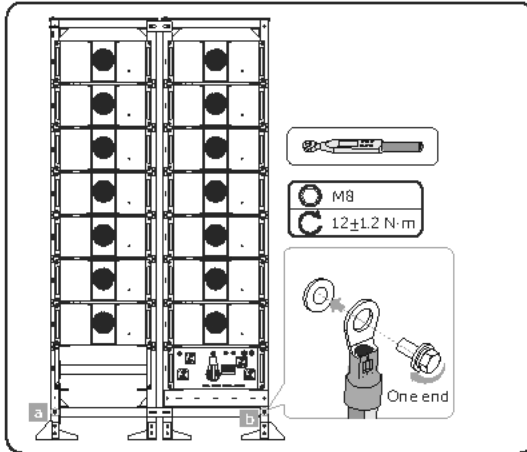

Figure 7-23 Tightening M8 screws

- Step 2:** Insert M8 screws (Part J) into the ring terminal at the other end of the PE cable and grounding plate, and then tighten it (torque: 12 ± 1.2 N·m).

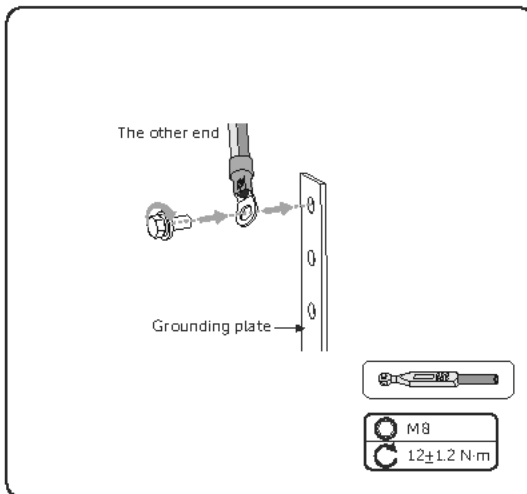

Figure 7-24 Tightening M8 screws

7.2.2 Fan Power Cable Connection

Step 1: Push the left and right covers of battery pack.

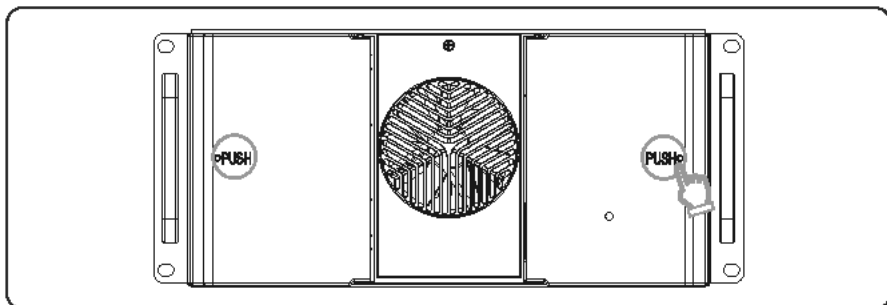

Figure 7-25 Pushing covers

Step 2: Connect and fix the fan power cable (Part B2) between battery packs (except for the two top battery packs).

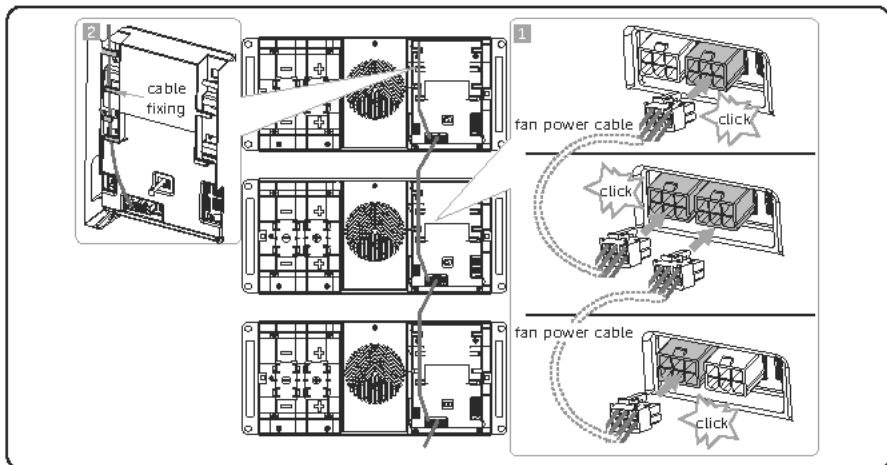

Figure 7-26 Fan power cable connection

Step 5: Connect the fan power cable (Part C1) between the high-voltage box and socket.

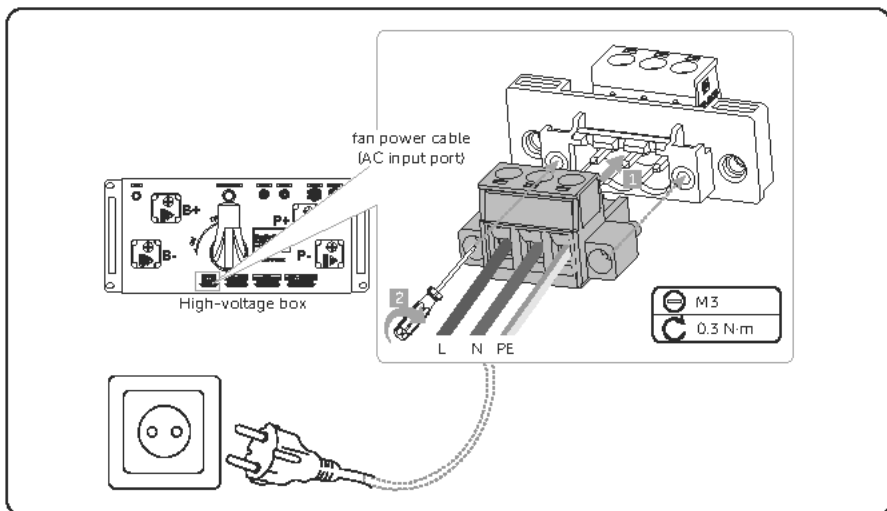

Figure 7-29 Fan power cable connection

7.2.3 Communication Connection

Step 1: Connect and fix the communication cable (Part C2) between battery packs (except for the two top battery packs).

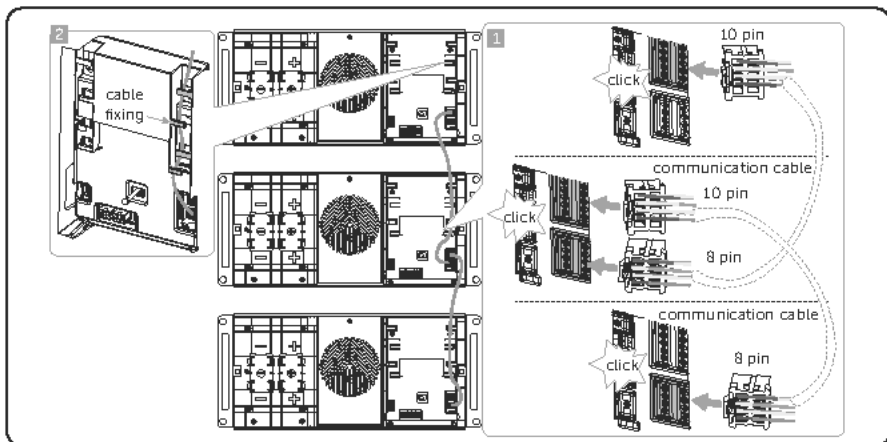

Figure 7-30 Communication cable connection

Step 2: Connect and fix the communication cable (Part C3) between two top battery packs.

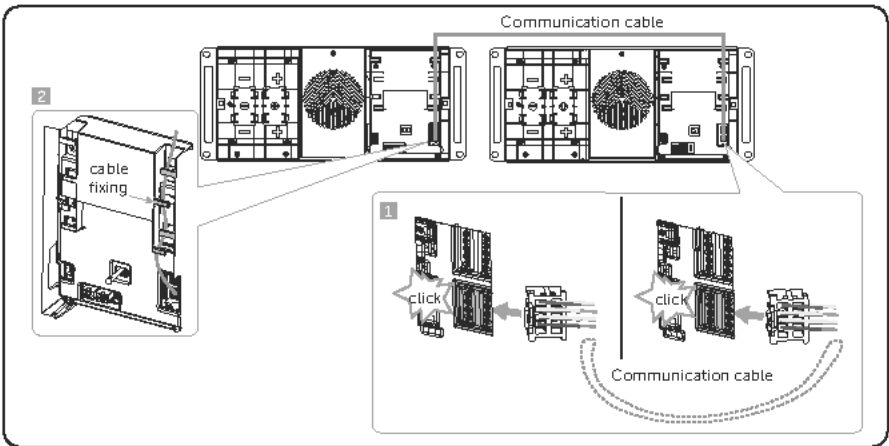

Figure 7-31 Communication cable connection

Step 3: Connect the communication cable (Part A1) between battery pack and high-voltage box. Thread the cables through the cable tie mount on the cable tray bracket (Part L).

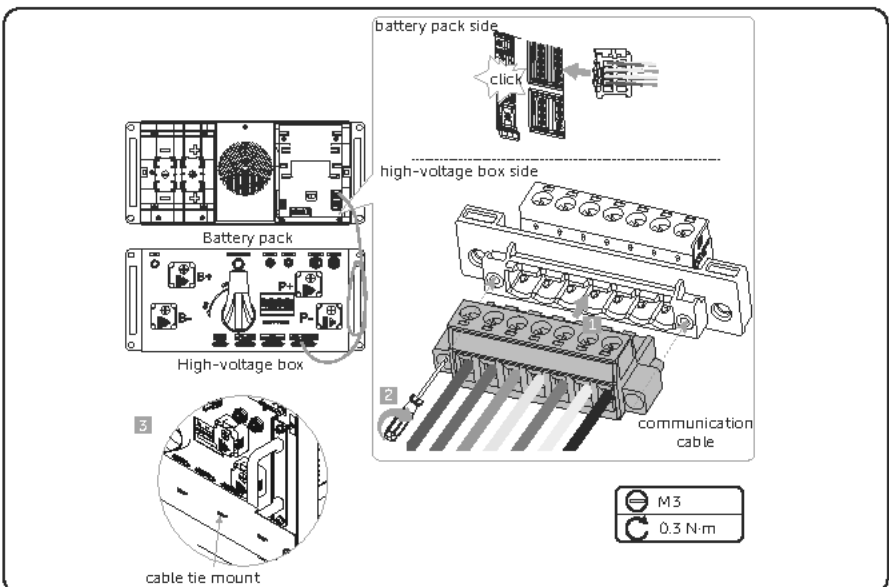

Figure 7-32 Communication cable connection

Step 4: Connect the communication cable (Part B1) between the high-voltage box and inverter.

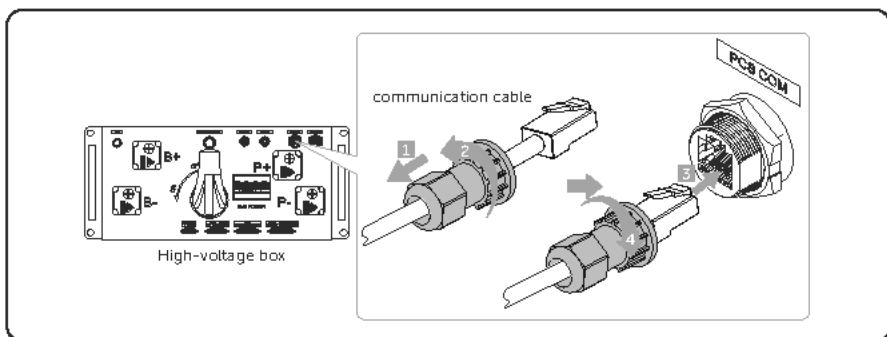

Figure 7-33 Communication cable connection

NOTICE!

- For inverter side wiring, please refer to "BMS communication connection".

Step 5: Insert the terminal resistance (Part I1) into the communication port (8 pin) in the top battery pack.

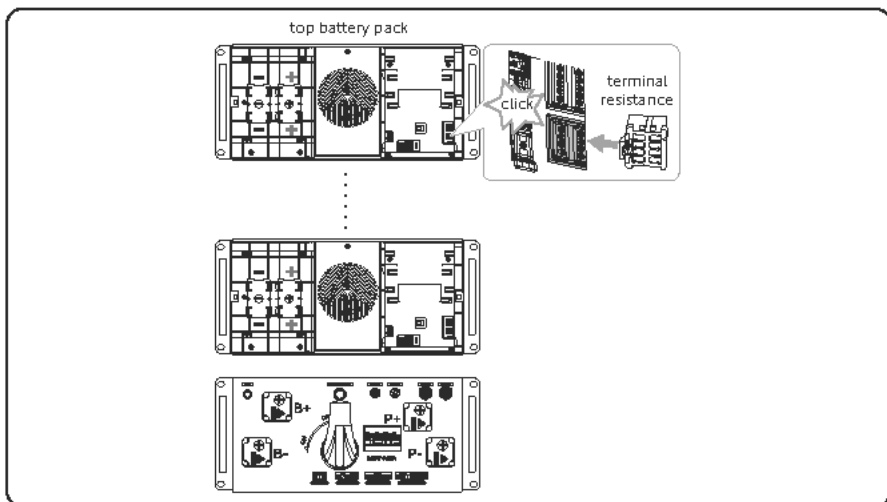

Figure 7-34 Terminal resistance connection

7.2.4 Copper Bar Connection



WARNING!

- To prevent a short circuit and avoid losing the cover, please strictly follow the steps below: **remove the cover on the negative(-) port** → **connect the copper bar/power cable to the negative(-) port** → **recover the cover to the negative(-) port** → **remove the cover on the positive(+) port** → **connect the copper bar to the positive(+) port** → **recover the cover to the positive(+) port.**

The order of copper bar connection is shown as follows:

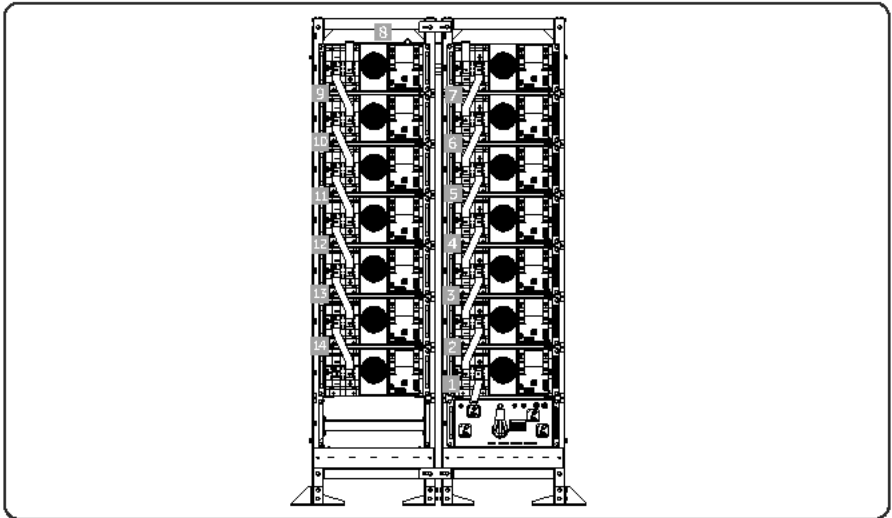

Figure 7-35 Copper bar connection sequence

Connection procedure

Step 1: Connect copper bar between battery packs.

- Remove the cover of positive or negative port of battery pack.
- Secure the copper bar (Part A2) and pin by inserting and tightening M8 nut (Part D2) with a torque wrench (torque: 7~8 N·m).
- Reinstall the terminal cover.

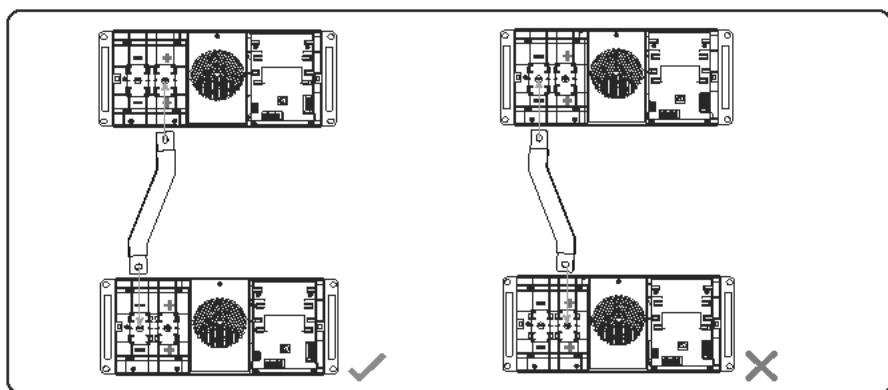

Figure 7-36 Copper bar connection on the right bracket

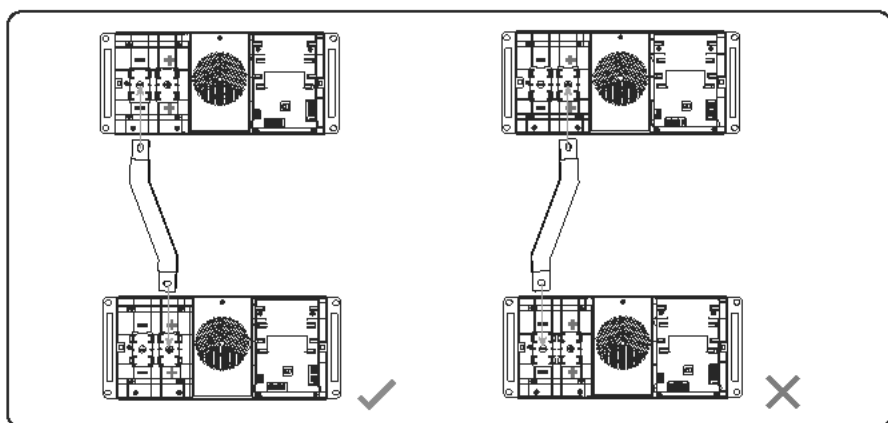

Figure 7-37 Copper bar connection on the left bracket

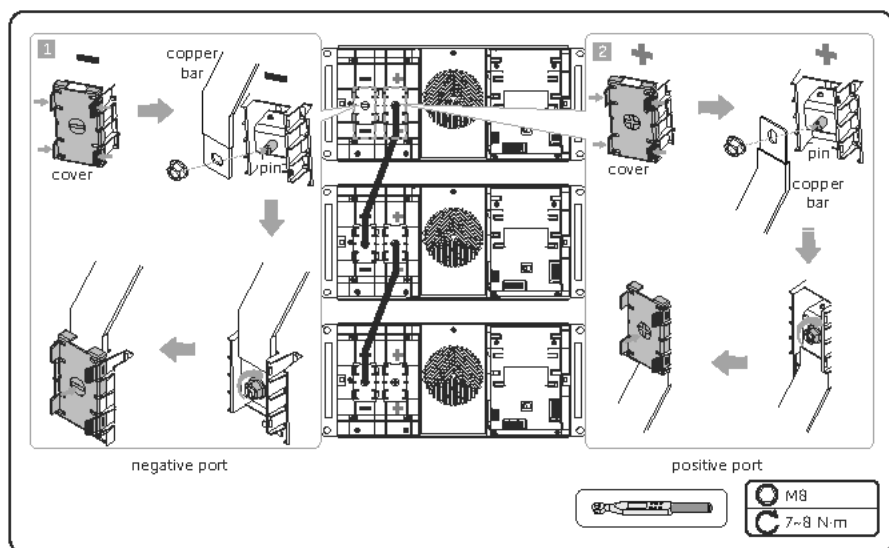

Figure 7-38 Copper bar connection

Step 2: Connect copper bar between top battery packs.

- Remove the cover of positive or negative port of top battery packs.
- Secure the copper bar (Part E2) and pin by inserting and tightening M8 nut with a torque wrench (torque: 7~8 N·m).
- Reinstall the terminal cover.

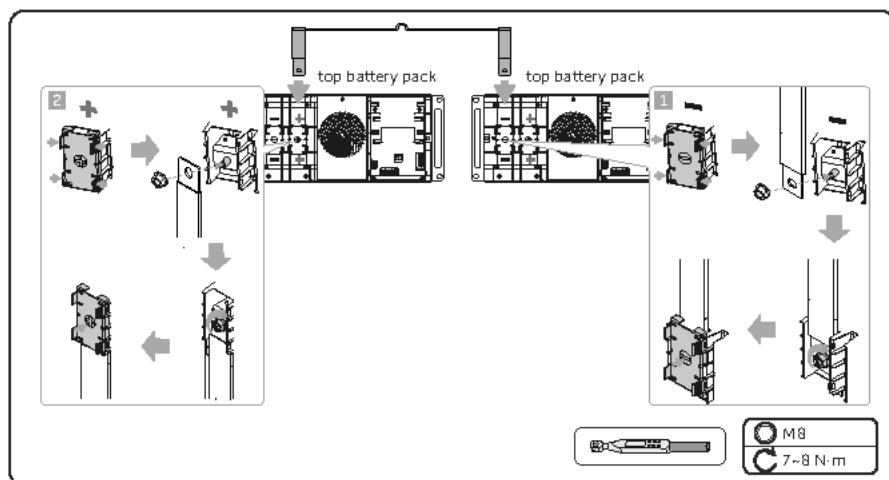

Figure 7-39 Copper bar connection

Step 3: Connect copper bar between battery pack and high-voltage box.

- a. Remove the cover of positive port of battery pack.
- b. Align the screw hole of copper bar (Part J1) with pin. Insert and tighten M8 nut to secure copper bar with a torque wrench (torque: 7~8 N·m).
- c. Reinstall the cover.
- d. Remove the cover of B+ port of high-voltage box.
- e. Unscrew M8 screw and insert copper bar into B+ port.
- f. Insert and tighten M8 screw to secure copper bar with a torque wrench (torque: 7~8 N·m).
- g. Reinstall the cover.

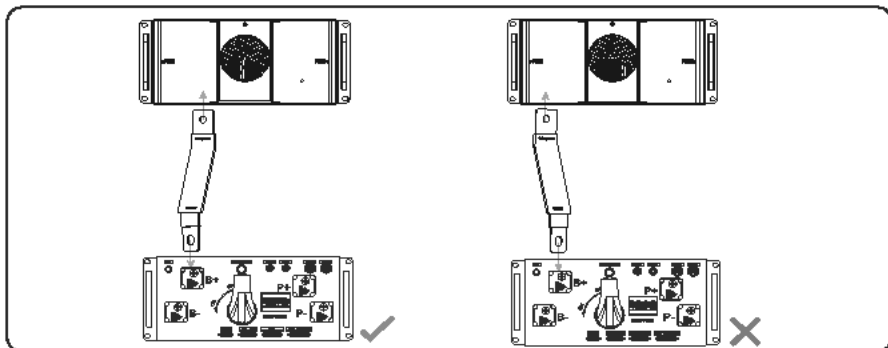

Figure 7-40 Copper bar connection

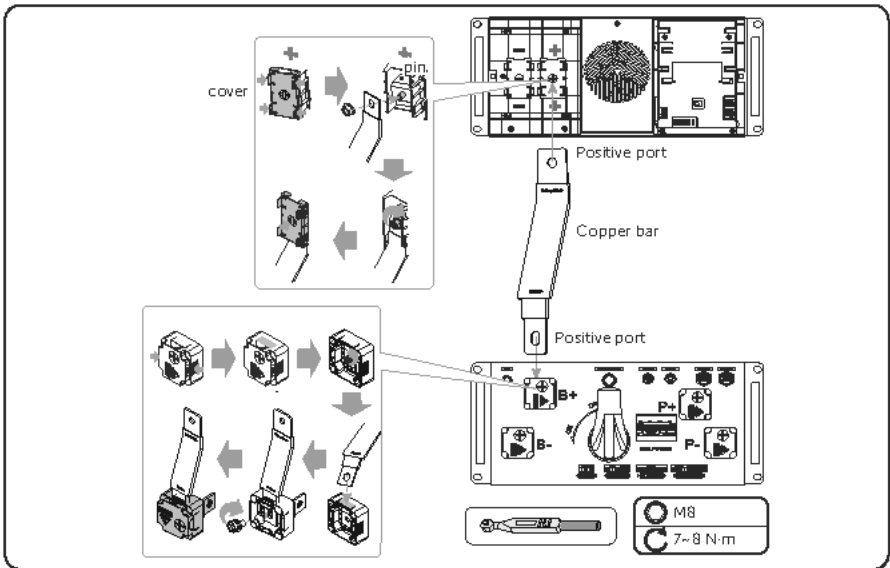

Figure 7-41 Copper bar connection

7.2.5 Power Cable Connection

Step 1: Connect negative power cable (Part H1) between high-voltage box and battery pack.

- Remove the cover of negative port of the bottom battery pack on the left bracket.
- Align the terminal of negative power cable with pin. Insert and tighten M8 nut to secure negative power cable with a torque wrench (torque: 7~8 N·m).
- Reinstall the cover.
- Remove the cover of B- port of high-voltage box.
- Unscrew M8 screw and insert the terminal of negative power cable into B- port.
- Insert and tighten M8 screw to secure negative power cable with a torque wrench (torque: 7~8 N·m).
- Reinstall the cover.
- Thread the cables through the cable tie mount on the cable tray bracket (Part L).

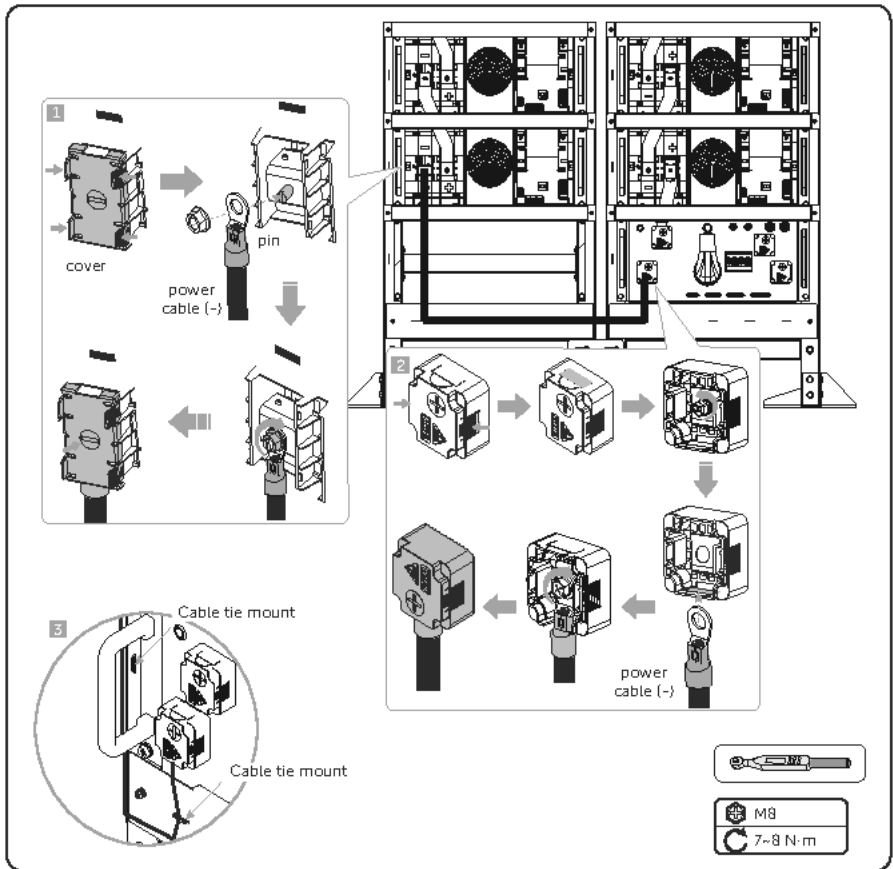

Figure 7-42 Power cable connection

- Step 2:** Connect the positive and negative power cables (Part D1 and E1) between the high-voltage box and inverter.
- Remove the cover of P+ and P- ports of high-voltage box.
 - Unscrew M8 screw and insert the terminal of negative and positive power cables into P+ and P- ports.
 - Insert and tighten M8 screw with a torque wrench (torque: 7~8 N·m).
 - Reinstall the cover.
 - Thread the cables through the cable tie mount on the cable tray bracket (Part L).

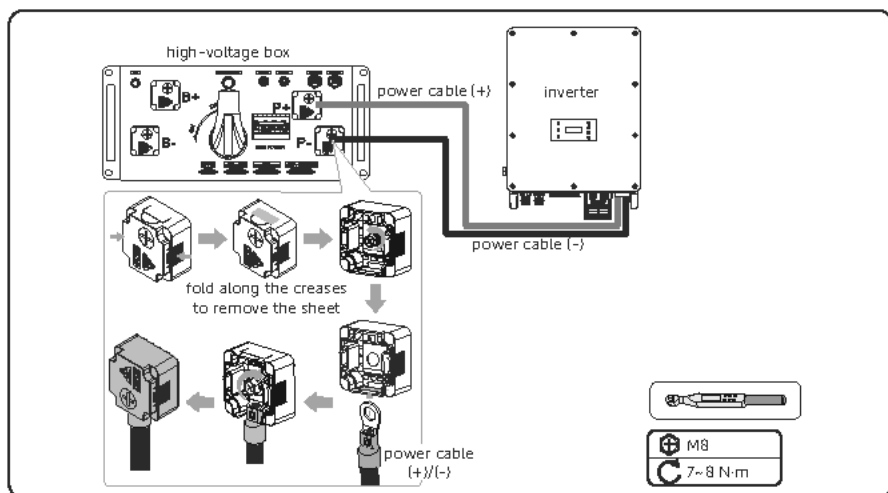

Figure 7-43 Power cables connection

NOTICE!

- For inverter side wiring, please refer to "7.3.5 Battery Power Cable Connection".

Step 3: Check if the wiring is correct according to the wiring diagram below.

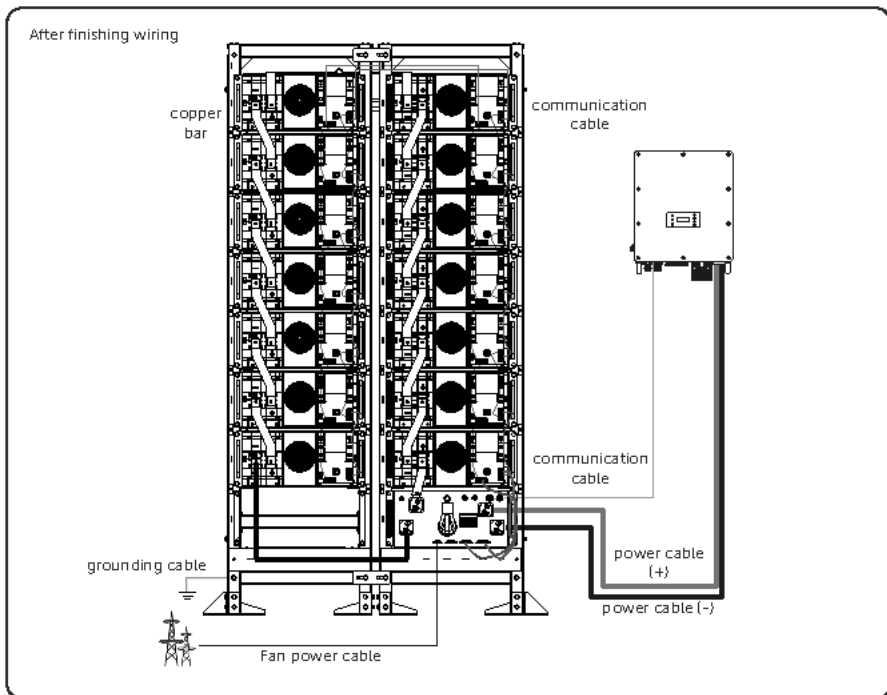

Figure 7-44 Wiring diagram (dual bracket)

Step 4: Close battery pack covers.

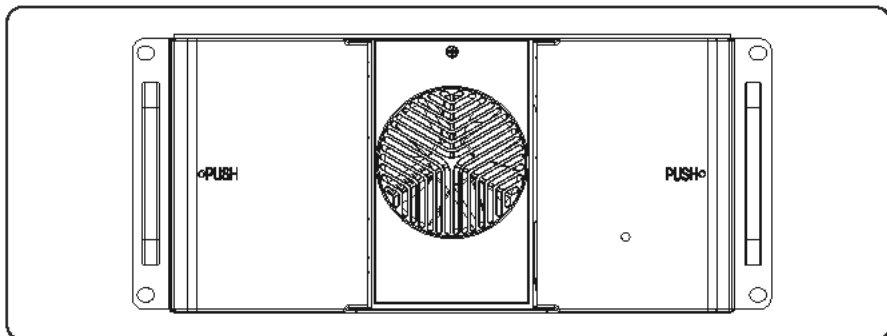

Figure 7-45 Closing battery pack cover

Step 5: Attach protection bar (Part G) (14 pcs) by inserting and tightening M5 screws (Part K) (28 pcs) with a torque wrench (Torque: 3 ± 0.3 N·m).

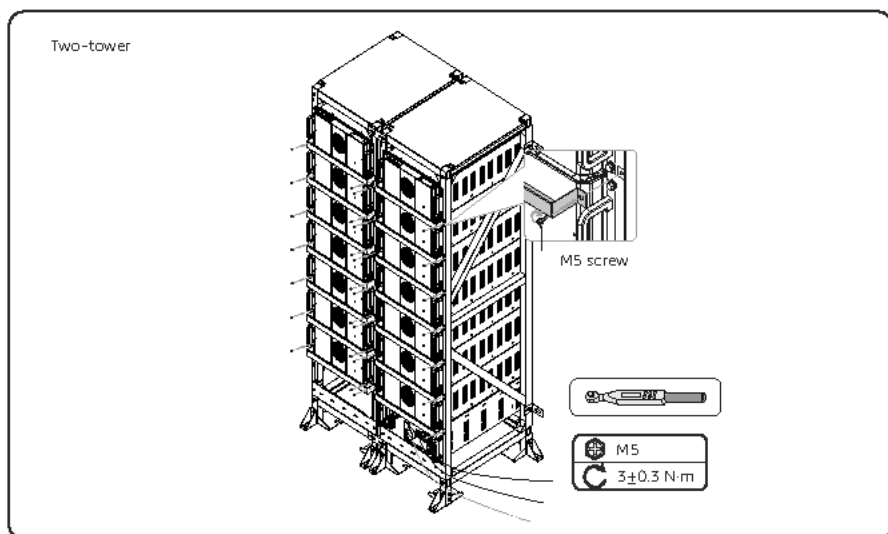

Figure 7-46 Attaching protection bar

7.3 Inverter Wiring

⚠ DANGER!

- Before electrical connection, make sure the DC switches and AC breakers are disconnected. Otherwise, electrical shock may be caused by high voltage, resulting in serious personal injury or death.

⚠ WARNING!

- Only the qualified personnel can perform the electrical connection following the local standards and requirements.
- Follow this manual or other related document to wire connection. The inverter damage caused by incorrect cabling is not in the scope of warranty.
- Use insulated tools and wear personal protective equipment throughout the electrical connection process.

NOTICE!

- When the inverter is wall-mounted or is installed on a battery cabinet, the wiring procedure and electrical connection method on the inverter are the same.

7.3.1 Terminals of Inverter

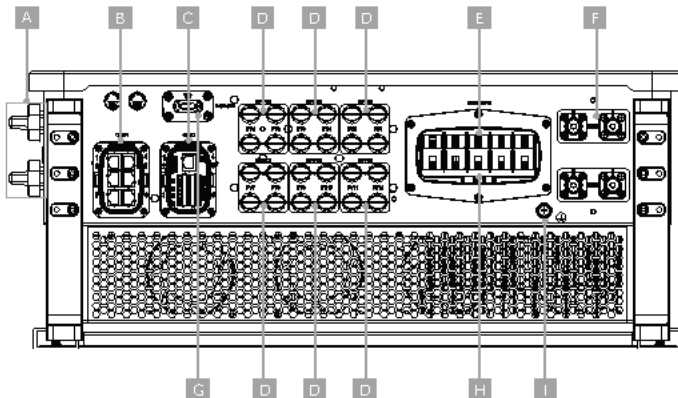



Figure 7-47 Terminals of Inverter

Table 7-3 Description of terminals

Item	Description	Decisive voltage class
A	DC switch (including DC switch 1 and DC switch 2)	-
B	COM 1 communication terminal (including Parallel-1, Parallel-2, BMS-1, BMS-2, RS485, DRM)	DVC-A
C	COM 2 communication terminal (including Ripple control, DIO, Meter/CT)	DVC-A
D	PV connection terminal (PV1~PV5 terminals for X3-AELIO-49.9K and X3-AELIO-50K; PV1~PV6 terminals for X3-AELIO-60K)	DVC-C
E	EPS connection terminal	DVC-C
F	Battery connection terminal (including BAT 1 and BAT 2)	DVC-C
G	Dongle terminal	DVC-A
H	Grid connection terminal	DVC-C
I	Ground connection point	-

7.3.2 PE Connection

All non-current carrying metal parts of the equipment and other enclosures in the PV system must be grounded reliably. The PE point at the AC output terminal is used only as a PE equipotential point, not a substitute for the PE point on the enclosure. The connection point has been labeled with the following label:  We recommend that the inverter is earthed to a nearby ground point.

CAUTION!

- In compliance with IEC62109-2, X3-AELIO series inverter has the grounding detection function which is used to check whether the inverter is properly grounded before it starts. If the inverter is not connected with earth, the inverter will turn on a red light and report **Earth Relay Fault**.

PE connection procedures

Step 1: Strip the insulation of the conductor with a wire stripper.

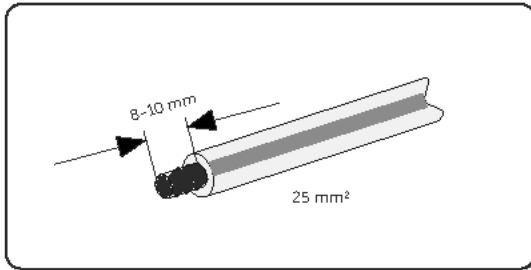

Figure 7-48 Stripping the PE cable

Step 2: Pull the Ø13 mm heat-shrink tubing over the PE cable and insert the stripped section into the OT terminal (part D5).

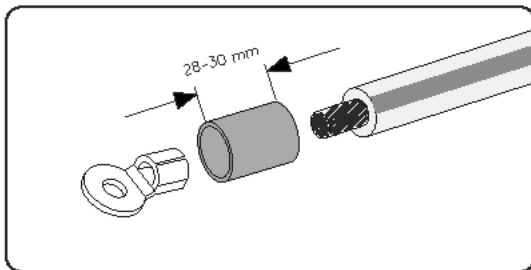

Figure 7-49 Installing the tubing and OT terminal

Step 3: Crimp it with a crimping tool, pull the heat-shrink tubing over the stripped section of the OT terminal, and use a heat gun to shrink it so that it can be firmly contacted with the terminal.

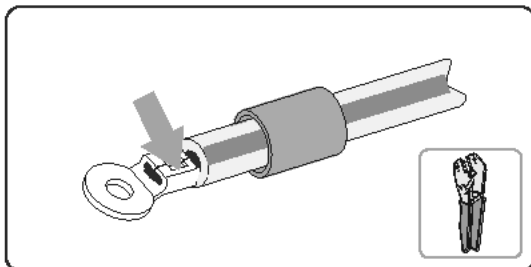

Figure 7-50 Crimping the cable

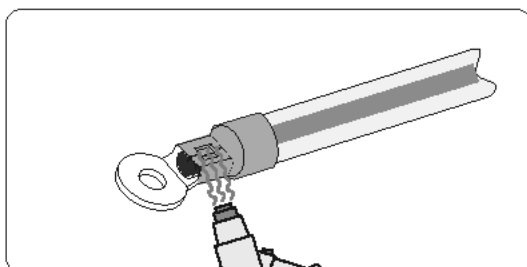

Figure 7-51 shrinking the tubing

Step 4: Loosen the PE screw on the inverter with a cross screwdriver.

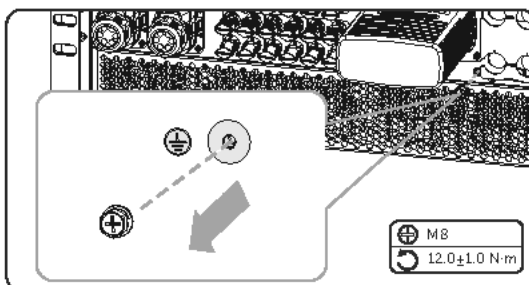

Figure 7-52 Uninstalling the screw

Step 5: Connect the assembled PE cable to the inverter and secure it with the original screw. (Torque: 12.0 ± 1.0 N·m)

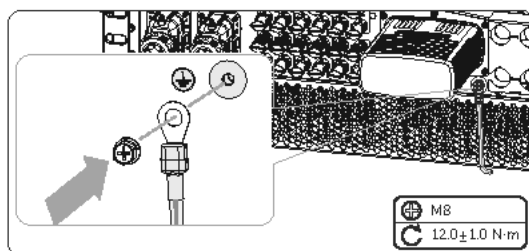

Figure 7-53 Securing the PE cable

7.3.3 AC Connection

NOTICE!

- Before connecting the inverter to the grid, approval must be received by local utility as required by national and state interconnection regulations.

The inverter has an EPS function. When the grid is connected, the inverter outputs go through the Grid terminal, and when the grid is disconnected, the inverter outputs go through the EPS terminal.

Requirements for AC connection

- Grid voltage requirement
 - » The grid voltage must be within the permissible range. The inverter is suitable for rated voltage 400V/230V, 380/220V, frequency 50/60Hz. Other technical requests should comply with the requirement of the local public grid.
- RCD requirement
 - » The inverter does not require an external residual-current device when operating. If an external RCD is required by local regulations, it is recommended to use a Type-A RCD with the value of 300 mA. When required by local regulations, the use of an RCD type B is permitted.
- AC breaker requirement
 - » An AC breaker that matches the power of the inverter must be connected between the inverter output and the power grid, and each inverter must be equipped with an independent breaker or other load disconnection unit to ensure the safe disconnection from the grid. Refer to "5.3 Additionally Required Materials" for specific data of AC breaker of Grid and EPS.
- Load requirement
 - » It is prohibited to connect any load between inverter and AC switch that directly connects to the inverter.
- EPS load requirement
 - » Do not connect sensitive precision instruments or medical equipment to the EPS terminal.
 - » Ensure that the EPS load rated power is within the EPS rated output power range. Otherwise, the inverter will report an **EPS Overload Fault** warning. When **EPS Overload Fault** occurs, turn off some loads to make sure it is within the EPS rated output power range, and the inverter will return to normal after **ESC** key on the LCD screen pressed.
 - » For inductive load such as fridge, air conditioner, washing machine, etc., ensure that the start power does not exceed the EPS peak power.

Table 7-4 EPS load information

Type of load	Equipment	Start power
Resistive load	Lamp	Equal to rated power
	Fan	Equal to rated power
	Hairdryer	Equal to rated power
Inductive load	Fridge	3-5 times rated power
	Air conditioner	3-6 times rated power
	Washing machine	3-5 times rated power
	Microwave oven	3-5 times rated power

* Please refer to the nominal current of the equipment for the actual start current.

Wiring procedures

NOTICE!

- When the inverter is connected to a battery cabinet, Grid and EPS cable crimped with AC connectors are prepared in the accessory of the cabinet and installers do not need to make cables.

Step 1: Prepare a Grid cable (five-core copper wire) and a EPS cable (five-core copper wire) and strip the insulation of the Grid and EPS cable as below. Remove the cable padding inside the insulation.

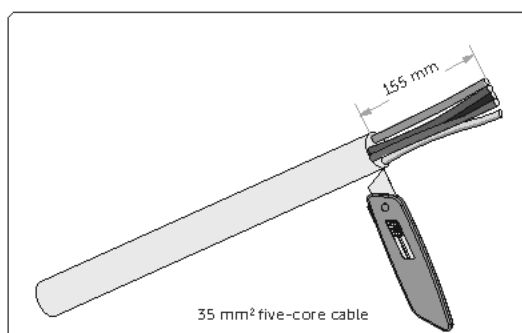

Figure 7-54 Stripping the Grid cable

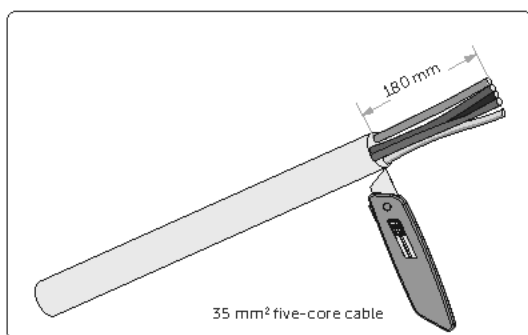

Figure 7-55 Stripping the EPS cable

Step 2: Trim L1, L2, L3, N and grounding cable of the Grid and EPS cable. Keep each cable at a length in accordance with the table below.

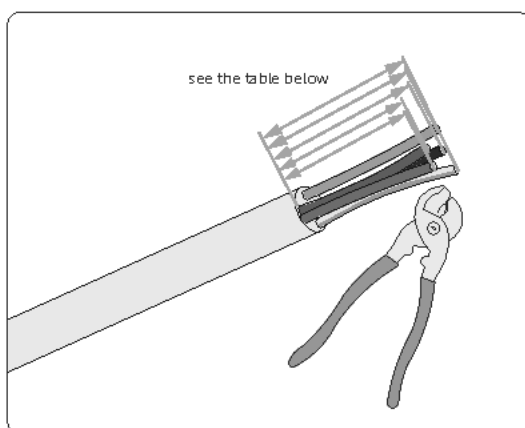

Figure 7-56 Trimming cables of the Grid and EPS cable

Table 7-5 Length of each cable of the Grid and EPS cable

Type of cable	Number of each cable	Length of cable (mm)
Grid cable	Grid_N	135
	Grid_L1	135
	Grid_L2	145
	Grid_L3	145
	Grid_PE	155
EPS cable	EPS_N	180

Type of cable	Number of each cable	Length of cable (mm)
EPS cable	EPS_L1	170
	EPS_L2	170
	EPS_L3	160
	EPS_PE	160

Step 3: Strip the insulation of L1, L2, L3, N and grounding cable of the Grid and EPS cable at a length of 16 mm.

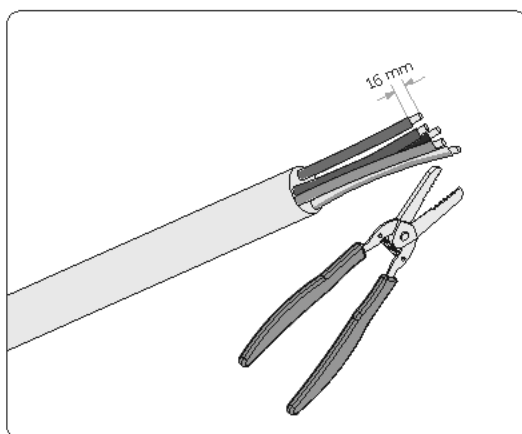

Figure 7-57 Stripping cables

Step 4: Loosen the swivel nuts of the AC connector (part O5) to disassemble it as below.

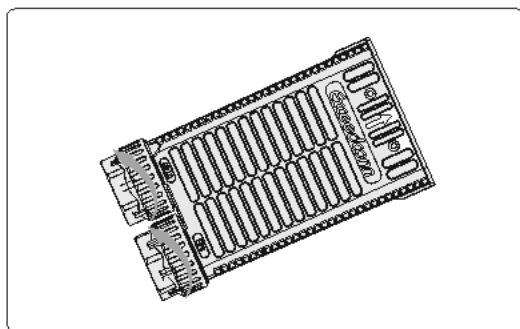

Figure 7-58 Disassembling the AC connector

Step 5: Disassemble the AC connector. Deal with the sealing plugs with the diameter of Grid and EPS cable used. Installers remove seals from a smaller to a larger one in accordance with the diameter of cables selected. If the diameter of the cable used is over 33 mm, remove the smallest seal No.1. If the diameter of the cable is 29~33 mm, cut the membrane inside the seal No.1 and thread cable through it.

Table 7-6 Selection of AC connector seals

Seal No.	Diameter of the seal bore (mm)	Diameter of cable selected (mm)
1	34	29~33
2	39	33~38
3	44	38~43
4	49	43~48

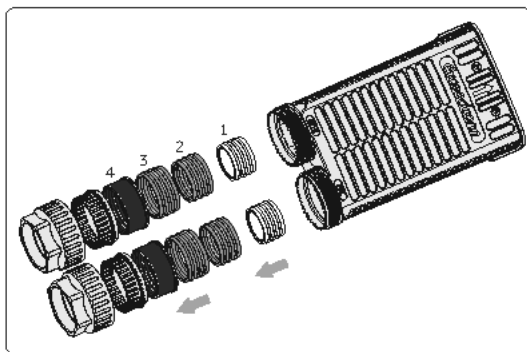

Figure 7-59 Disassembling the swivel nuts

Step 6: Thread the stripped Grid and EPS cable through the AC connector.

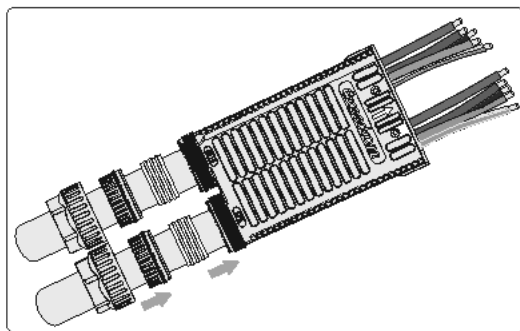

Figure 7-60 Threading cables through the AC connector

- Step 7:** Cut the $\varnothing 13$ mm heat shrink tubings at the length of 25-30 mm. Thread L1, L2, L3, N and grounding cable of Grid and EPS cable through the heat shrink tubings and insert AC terminals (part N5) into each cable.

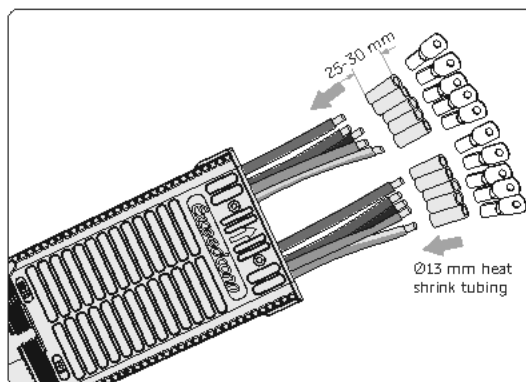

Figure 7-61 Assembling tubings and AC terminals

- Step 8:** Crimp the AC terminals. Pull the tubings to cover the joints of the stripped cable and AC terminal and then use a heat gun to shrink the tubings.

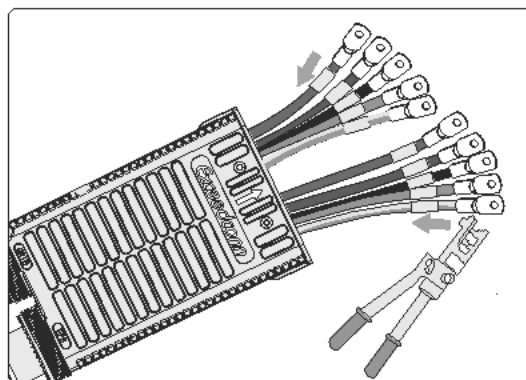

Figure 7-62 Crimping AC terminals

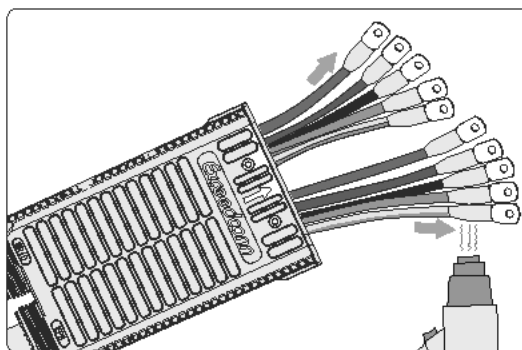

Figure 7-63 Shrinking the tubings

Step 9: Secure the L1, L2, L3, N and grounding conductors of the assembled Grid cable with M6 screws. (Torque: 5.0 ± 1 N·m) Make sure the conductors are correctly assigned and firmly seated in the terminals.

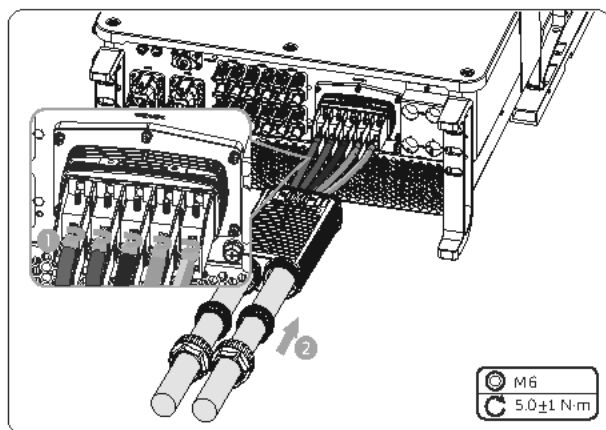

Figure 7-64 Connecting the Grid cable

- Step 10:** Secure the L1, L2, L3, N and grounding conductors of the assembled EPS cable with M6 screws. (Torque: 5.0 ± 1 N·m) Make sure the conductors are correctly assigned and firmly seated in the terminals. Connect the enclosure of the AC connector to the inverter, insert the waterproof seals into the AC connector, and tighten the swivel nuts of the connector.

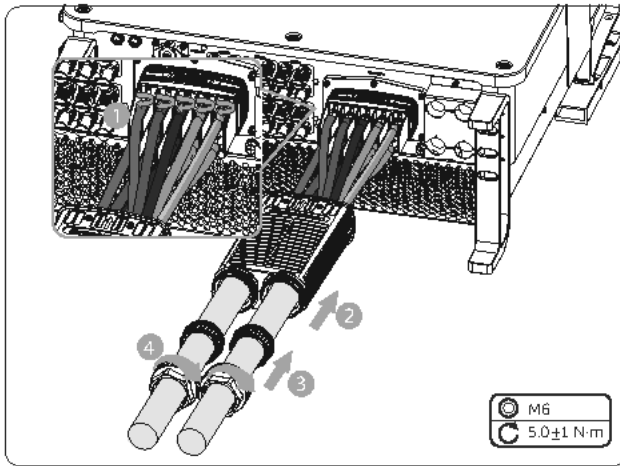

Figure 7-65 Connecting the EPS cable

- Step 11:** Connect the assembled AC connector to the AC port of the inverter, tighten the two M4*12 screws on the AC connector enclosure (Torque: 1.6 ± 0.1 N·m) and tighten the swivel nuts clockwise.

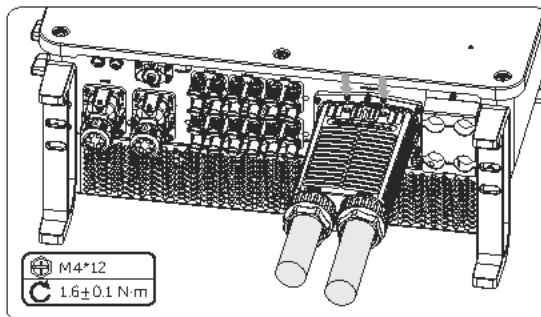

Figure 7-66 Securing the AC connector on the inverter

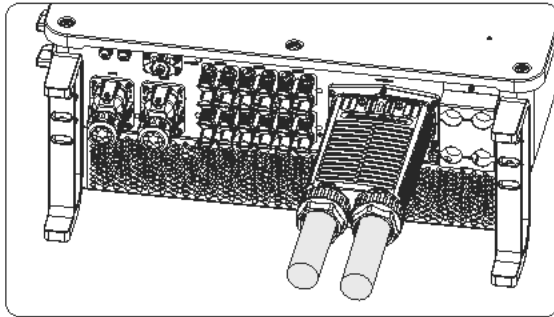

Figure 7-67 Well connected aAC connector

 DANGER!

- Before powering on the inverter, make sure the AC connector has been installed correctly on the Grid and EPS terminal even if the EPS terminal is not wired. Otherwise, electrical shock may be caused by high voltage, resulting in serious personal injury or death.

 WARNING!

- Reinstall AC terminal caps immediately after removing the connectors from terminals.

7.3.4 PV Connection



- High DC voltage will be generated by PV modules when exposed to sunlight. Death or lethal injuries will occur due to electric shock.
- Make sure the DC switch and AC breaker are disconnected from the inverter before connection.
- Make sure that the PV module output is well insulated to ground.



- Power is fed from more than one source and more than one live circuit.

Requirements for PV connection

- Open circuit voltage and working voltage
 - » The open circuit voltage of the module array should be less than the maximum PV input voltage (1000 V) of the inverter. Otherwise the inverter may be damaged.
 - » The working voltage should be within the MPPT voltage range (160-950 V). Otherwise, the inverter will prompt **PV Volt Fault**. Consider the impact of low temperature on the voltage of the photovoltaic panels, as lower temperatures tend to result in higher voltages.
 - » The working voltage should be within the full load MPPT range (320-800V). Otherwise, the inverter will prompt derating protection.
- PV module
 - » The PV modules within the same MPPT channel are of the same brand. Additionally, the strings within the same channel should have identical quantities, and be aligned and tilted identically.
 - » The positive or negative pole of the PV modules is not grounded.
 - » The positive cables of the PV modules must be connected with positive DC connectors.
 - » The negative cables of the PV modules must be connected with negative DC connectors.

Wiring procedures

Step 1: Strip approx. 7 mm of the cable insulation.

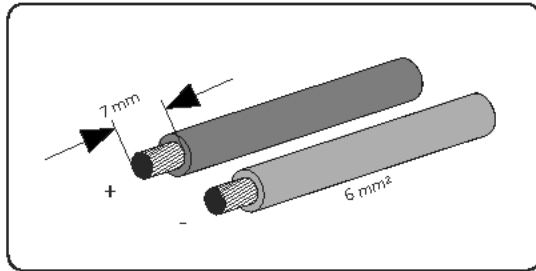

Figure 7-68 Stripping the PV cable

Step 2: Insert the stripped cable into the PV pin contact (part I5 and J5). Ensure that the stripped cable and the PV pin contact are of the same polarity. Crimp it with a crimping tool for PV terminal.

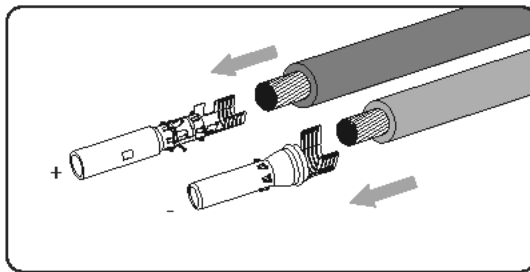

Figure 7-69 Inserting the PV pin contact

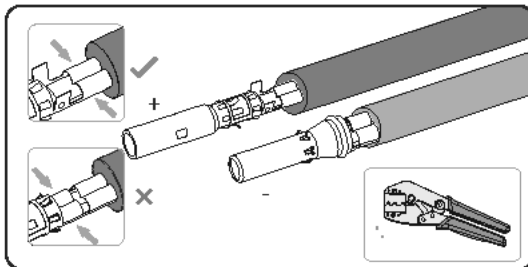

Figure 7-70 Crimping the terminal

⚠ WARNING!

- To mitigate the risk of fire, it is crucial to utilize a dedicated crimping tool specifically designed for PV installations to ensure secure and reliable connections.

- Step 3:** Thread the PV cable through the swivel nut and insert the cable into the PV connector (part I5 and J5) until a "Click" is heard. Gently pull the cable backward to ensure a firm connection. Tighten the swivel nut clockwise. Verify that the PV connectors have the correct polarity before connection.

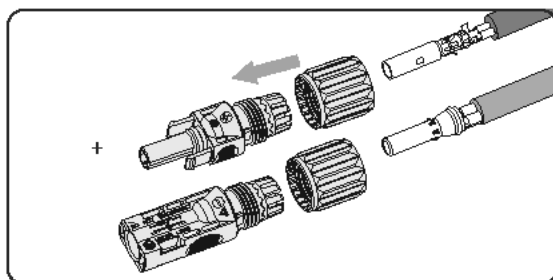

Figure 7-71 Threading the PV cable

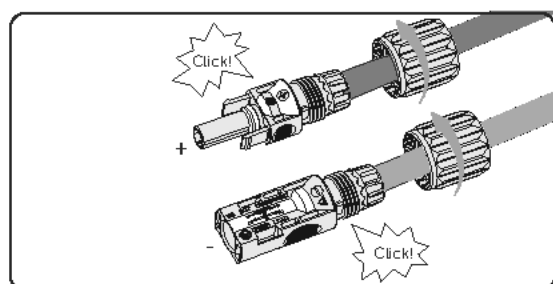

Figure 7-72 Securing the PV cable

- Step 4:** Use a multimeter to measure the positive and negative voltage of the assembled PV connectors. Make sure the open circuit voltage does not exceed the input limit of 1000 V.

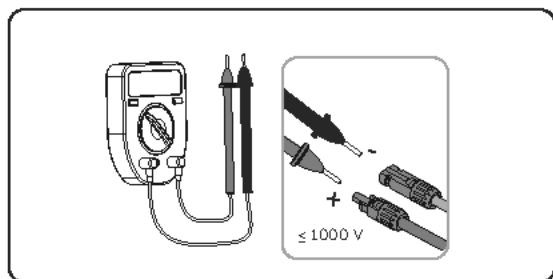

Figure 7-73 Measuring the voltage of PV connectors

NOTICE!

- If the voltage reading is negative, it indicates an incorrect DC input polarity. Please check if the wiring connections on the multimeter is correct or PV connectors are not mistakenly connected.

Step 5: Remove the PV terminal caps and connect the assembled PV connectors to corresponding terminals until there is an audible "Click". The PV+ on the string side must be connected to the PV+ on the inverter side, and the PV- on the string side must be connected to the PV- on the inverter side.

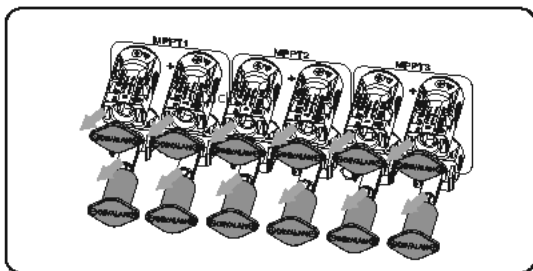

Figure 7-74 Connecting the PV cable

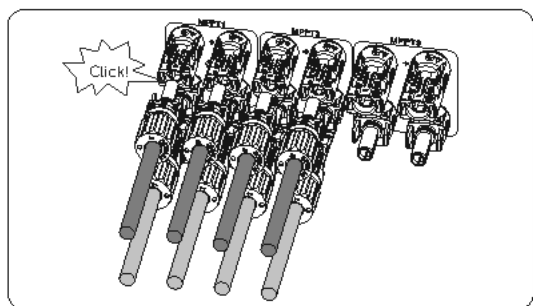

Figure 7-75 Connecting assembled PV cables to the inverter

- Step 6:** Seal the unused positive and negative PV terminals with corresponding PV dustproof buckles (part S5 and T5). Reinstall them immediately after removing the connectors from terminals.

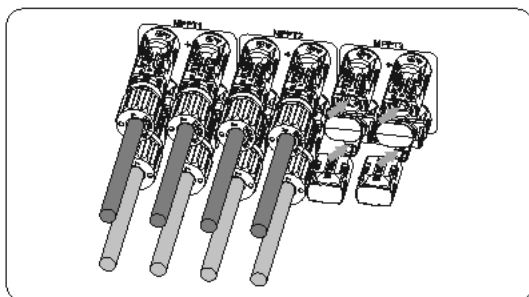

Figure 7-76 Installing PV dustproof buckles

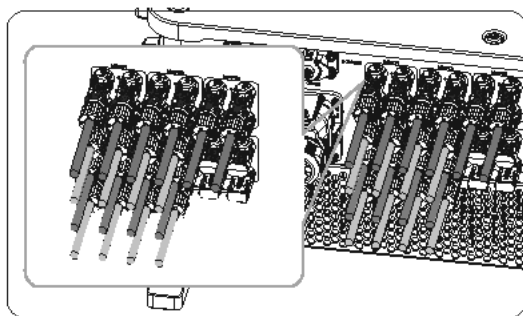

Figure 7-77 Well connected PV cables and dustproof buckles

7.3.5 Battery Power Cable Connection



- Make sure the breaker of battery is in OFF position.
- Always ensure correct polarity. Never reverse the polarity of the battery cables as this will result in inverter damage.

Requirments for battery connection

- Required battery
 - » Lithium-ion battery
 - » The inverter is equipped with two independent battery terminals, allowing for connection to two separate battery towers. Max charge and discharge current is 160 (80*2) A for each BAT terminal.
 - » Make sure the input voltage of each BAT terminal is higher than minimum voltage 180 V and lower than maximum input voltage 820 V.
- Micro circuit breaker (MCB)
 - » If local regulations mandate the use of a DC MCB between the battery and the inverter, install a non-polar DC MCB.
 - » Nominal voltage of DC MCB should be larger than maximum voltage of battery.
 - » See the documentation of battery for the current.

Wiring procedures

Step 1: Disassemble the battery connectors (part G5 and H5).

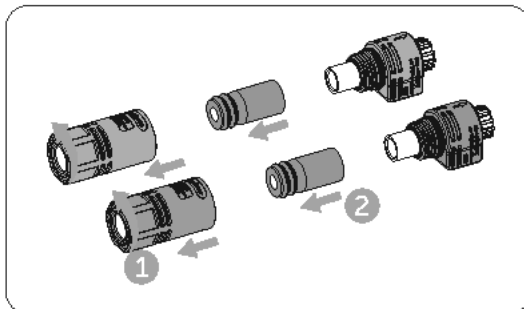

Figure 7-78 Disassembling battery connectors

Step 2: Thread the battery power cable through the swivel nut and then the cable support sleeve. Strip 15 ± 1 mm insulation off.

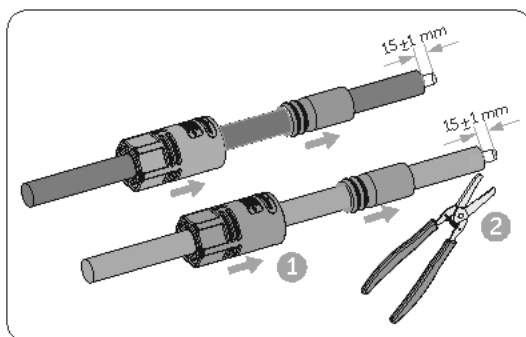

Figure 7-79 Stripping the battery power cable

Step 3: Insert the stripped cable into the connector enclosure. Ensure that the stripped cable and the enclosure are of the same polarity. Crimp it with a hydraulic plier at 7.2 ± 0.2 mm and ensure that the exposed core of the cable is no more than 1 mm.

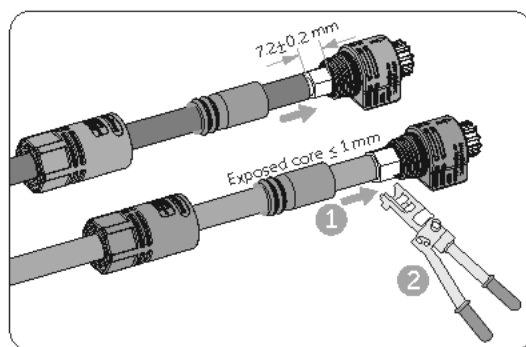

Figure 7-80 Crimping the terminal

NOTICE!

- Before the battery power cables are stripped, please ensure that the exposed core of cables should be less than 1 mm when the battery connectors are crimped.

Step 4: Pull the cable support sleeve over the crimped battery connector enclosure and then the swivel nut to the enclosure. Tighten the swivel nut.

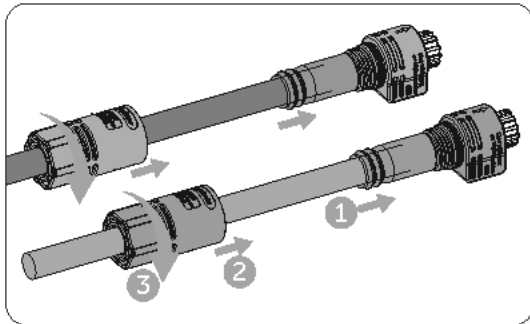

Figure 7-81 Tightening the battery connector

Step 5: Loosen the screws on the battery protective cover and remove the cover. Pull out the battery caps.

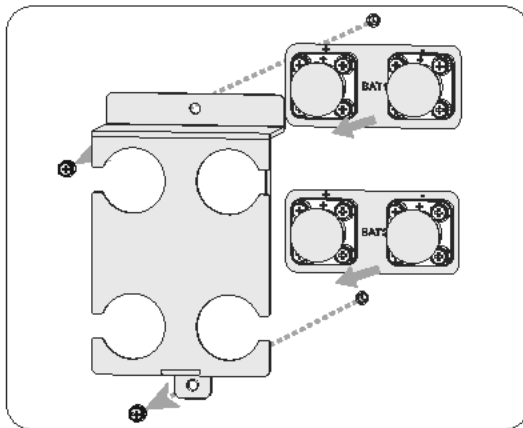

Figure 7-82 Removing the battery protective cover

NOTICE!

- The protective cover does not need to be removed and installed when you ordered a cable cover.

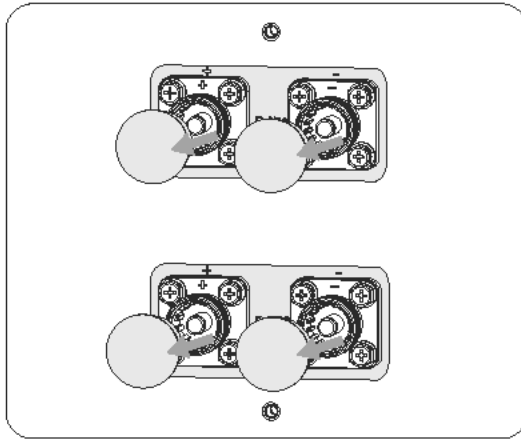

Figure 7-83 Removing battery caps

Step 6: Connect the assembled battery connectors to corresponding terminals until there is an audible "Click". The BAT+ on the string side must be connected to the BAT+ on the inverter side, and the BAT- on the string side must be connected to the BAT- on the inverter side. Gently pull the cable backward to ensure firm connection.

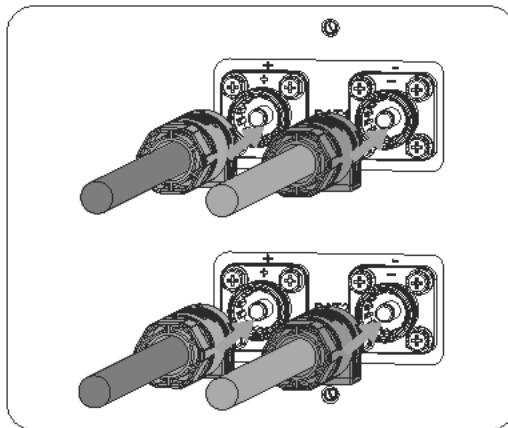

Figure 7-84 Connecting assembled battery cables

Step 7: After the battery cables are connected, install the battery protective cover and secure the cover on the inverter with screws.

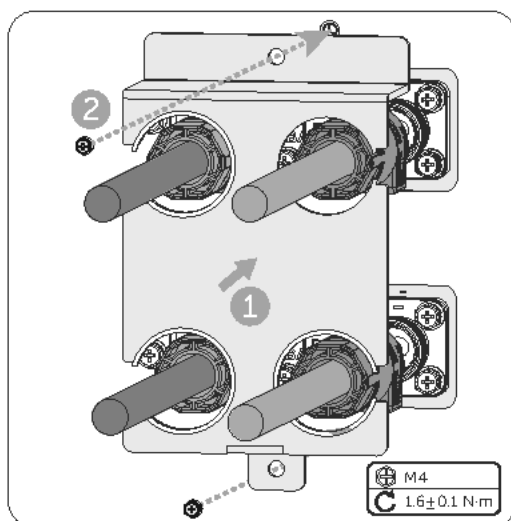

Figure 7-85 Installing the battery protective cover

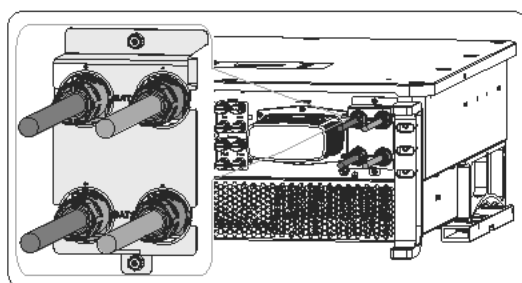

Figure 7-86 Well connected battery cables

WARNING!

- Seal the unused battery terminals with original terminal caps.
- Keep the terminal caps in a safe place if battery cables are connected to the inverter.
- Reinstall it immediately after removing the connectors from terminals.

7.3.6 COM 1 Communication Connection

Pin assignment of COM 1 terminal

The COM 1 terminal is used for parallel connection via Parallel-1 and Parallel-2 communication terminal, battery communication via BMS-1 and BMS-2 terminal, external equipment communication via RS485 and DRM function.

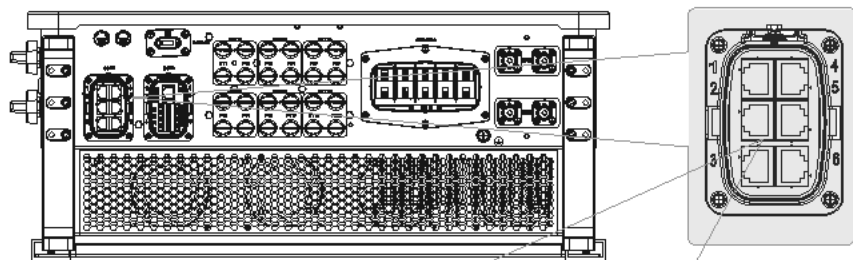

PARALLEL 1

- 1: PARALLEL_485A
- 2: PARALLEL_485B
- 3: DATA_BUS
- 4: PARALLEL_CANH
- 5: PARALLEL_CANL
- 6: GND_COM
- 7: PARALLEL_SYNC1
- 8: PARALLEL_SYNC2

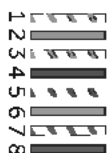

PARALLEL 2

- 1: PARALLEL_485A
- 2: PARALLEL_485B
- 3: DATA_BUS
- 4: PARALLEL_CANH
- 5: PARALLEL_CANL
- 6: GND_COM
- 7: PARALLEL_SYNC1
- 8: PARALLEL_SYNC2

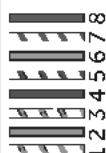

BMS1

- 1: BAT_TEMP
- 2: GND_COM
- 3: GND_COM
- 4: BMS1_CANH
- 5: BMS1_CANL
- 6: BAT_WAKEUP_POWER
- 7: BMS1_485A
- 8: BMS1_485B

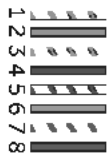

BMS2

- 1: BAT_TEMP
- 2: GND_COM
- 3: GND_COM
- 4: BMS2_CANH
- 5: BMS2_CANL
- 6: BAT_WAKEUP_POWER
- 7: BMS2_485A
- 8: BMS2_485B

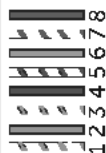

RS485

- 1: REMOTE_485A
- 2: REMOTE_485B
- 3: NC
- 4: PARALLEL_485AA
- 5: PARALLEL_485BB
- 6: NC
- 7: REMOTE_485A
- 8: REMOTE_485B



DRM

- 1: DRM1/5
- 2: DRM2/6
- 3: DRM3/7
- 4: DRM4/8
- 5: +3.3V_COM
- 6: COM/DRM0
- 7: GND_COM
- 8: GND_COM

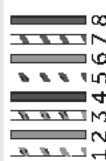

Parallel connection

The inverter provides the parallel connection function. One inverter will be set as the "Master inverter" to control the other "Slave inverters" in the system.

- Wiring procedure

Step 1: Loosen the screws on the COM 1 terminal. Pinch the tabs on the sides of the COM 1 connector enclosure and pull it at the same time to disassemble it.

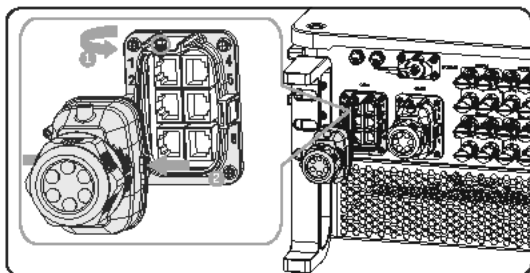

Figure 7-87 Removing the connector enclosure

Step 2: Anti-clockwise loosen the swivel nut and pull out the sealing plugs. Keep the sealing plugs still in the cable support sleeve if you choose not to connect the cable.

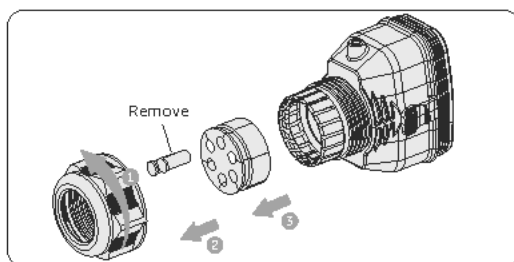

Figure 7-88 Disassembling the connector

Step 3: Thread the network cables.

- » Method 1: If your network cable has already been connected with RJ45 terminal, you can directly thread the cable through the swivel nut, cable support sleeve and connector enclosure in sequence.

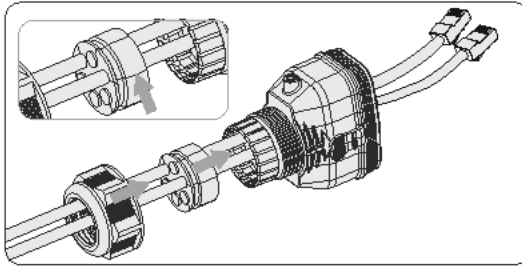

Figure 7-89 Threading the cables with RJ45 terminal

- » Method 2: If your network cable is not connected to an RJ45 terminal, you will need to assemble the cable before proceeding.

Thread the cables without RJ45 terminal through the swivel nut, cable support sleeve, and connector enclosure in sequence. Strip approx. 15 mm of the cable insulation.

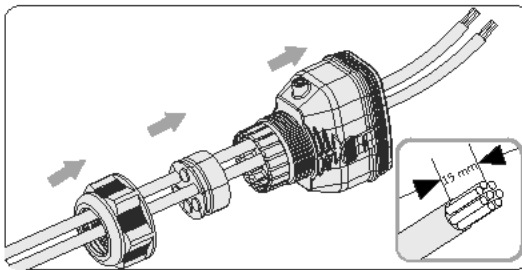

Figure 7-90 Threading the cables and stripping the insulation

Insert the stripped section into the RJ45 terminal (part E5). Crimp it tightly with a crimping tool for RJ45. Pay attention to pin order of RJ45 terminal.

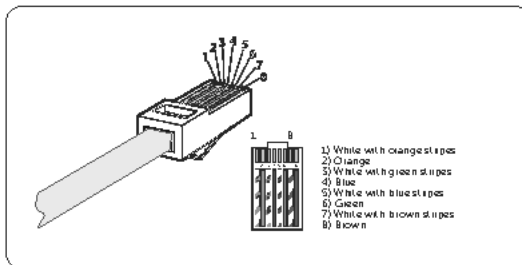

Figure 7-91 Crimping the communication cable

NOTICE!

- Use network cable tester to test the crimped cable before connecting to the inverter.

Step 4: Install the network cables with a crimped RJ45 terminal to Parallel-1 and Parallel-2 of cable clamp (part E5) according to the labeling.

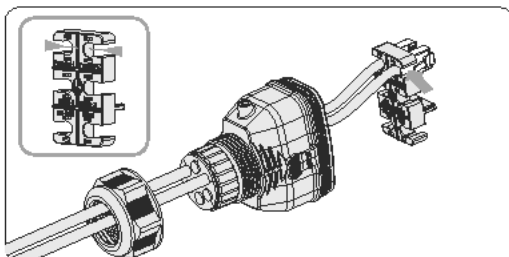

Figure 7-92 Installing the cable to the cable clamp

Step 5: Connect the assembled connector to COM 1 terminal. Ensure the cable clamp tongue is well inserted into the slot of terminal. You will hear an audible "Click" if it is connected securely. Lightly pull the cable for double check its connection.

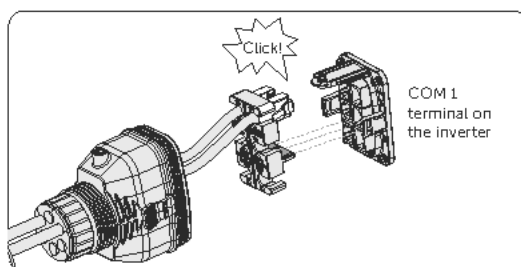

Figure 7-93 Inserting the connector to COM 1

- Step 6:** Secure the assembled connector on COM 1 terminal.
- Install the connector enclosure back into the COM 1 terminal.
 - Install the cable support sleeve into the enclosure.
 - Tighten M3 screw to secure it. (Torque: 1.2 ± 0.1 N·m)
 - Clockwise tighten the swivel nut to finish the COM 1 wiring connection.

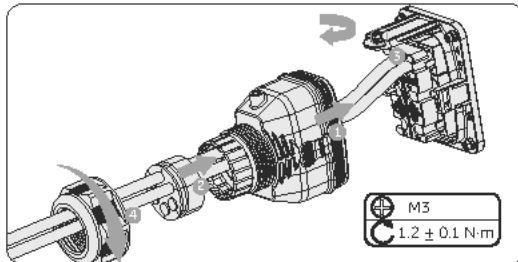

Figure 7-94 Securing the connector

BMS communication connection

Through BMS-1 and BMS-2 communication terminal, the inverter can be connected to two independent batteries of different capacities. The model of each battery must be the same.

- Wiring procedure

- Step 1:** Loosen the screws on the COM 1 terminal. Pinch the tabs on the sides of the COM1 connector enclosure and pull it at the same time to remove it.
- Step 2:** Anti-clockwise loosen the swivel nut and pull out the sealing plugs. Keep them still in the cable support sleeve if you choose not to connect the cable.
- Step 3:** Thread the cables through the swivel nut, cable support sleeve, and connector enclosure in sequence.
- Step 4:** Install the network cables to BMS-1 and BMS -2 of cable clamp according to the labeling.

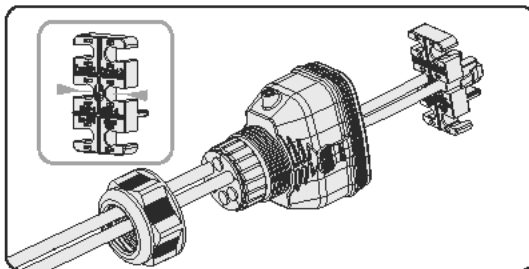

Figure 7-95 Installing RJ45 terminal to the cable clamp

- Step 5:** Connect the assembled connector to COM 1 terminal. Make sure the cable clamp tongue is well inserted into the slot of terminal. You will hear an audible "Click" if it is connected securely. Lightly pull the cable backward for double check its connection.

- Step 6:** Secure the assembled connector on COM 1 terminal.
- Install the connector enclosure back into the COM 1 terminal.
 - Install the cable support sleeve into the enclosure.
 - Tighten M3 screw to secure it. (Torque: 1.2 ± 0.1 N·m)
 - Clockwise tighten the swivel nut to finish the COM 1 wiring connection.

RS485 communication connection

For SolaX products, such as the Adapter Box, EV-Charger and etc., they can be connected to pin4 and pin5. As for pin1, pin2, pin7, and pin8 they can be utilized to connect devices other than SolaX products. If you require simultaneous connections of multiple devices, a splitter adapter can be employed.

NOTICE!

- Please refer to "14 Appendix" for the specific application of Adapter Box, EV-Charger and Datahub.
- Not all devices are compatible with 8 pin Network cables. In cases where 8 pin Network cables are not supported, it is required to re-crimp the RJ45 terminal according to the pin assignment.

- Wiring procedure

- Step 1:** Loosen the screws on the COM 1 terminal. Pinch the tabs on the sides of the COM 1 connector enclosure and pull it at the same time to remove it.
- Step 2:** Anti-clockwise loosen the swivel nut and pull out the sealing plugs. Keep the sealing plugs still in the cable support sleeve if you choose not to connect the cable.

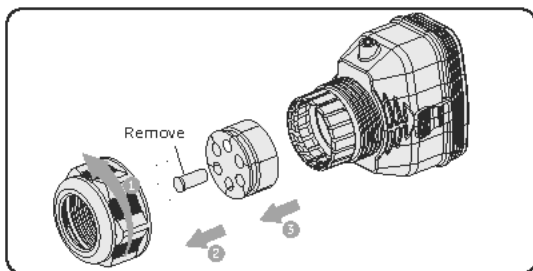

Figure 7-96 Disassembling the connector

- Step 3:** Thread the cables without RJ45 terminal through the swivel nut, cable support sleeve, and connector enclosure in sequence. Strip approx. 15 mm of the cable insulation.

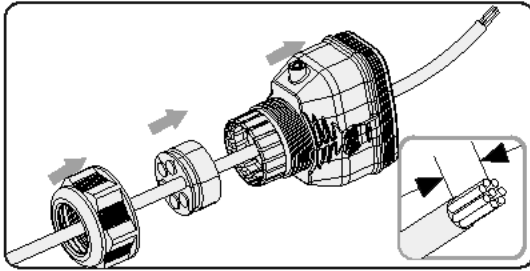

Figure 7-97 Threading the cables and stripping the insulation

Step 4: Insert the stripped section into the RJ45 terminal. Crimp it tightly with a crimping tool for RJ45. Pay attention to pin order of RJ45 terminal.

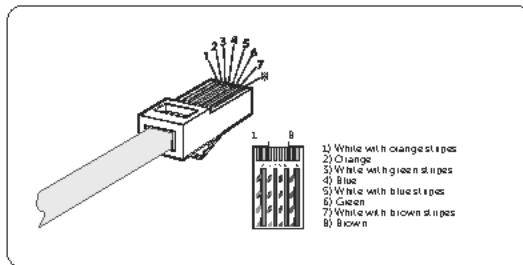

Figure 7-98 Crimping the communication cable

NOTICE!

- Use network cable tester to test the crimped cable before connecting to the inverter.

Step 5: Install the network cable of the crimped RJ45 terminal to RS485 of cable clamp according to the labeling.

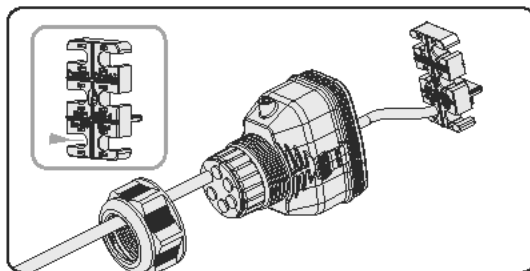

Figure 7-99 Installing RJ45 terminal to the cable clamp

Step 6: Connect the assembled connector to COM 1 terminal. Make sure the cable clamp tongue is well inserted into the slot of terminal. You will hear an audible "Click" if it is connected securely. Lightly pull the cable backward for double check its connection.

Step 7: Secure the assembled connector on COM 1 terminal.

- Install the connector enclosure back into the COM 1 terminal.
- Install the cable support sleeve into the enclosure.
- Tighten M3 screw to secure it. (Torque: 1.2 ± 0.1 N·m)
- Clockwise tighten the swivel nut to finish the COM 1 wiring connection.

DRM connection (applicable to AS/NZS 4777)

According to AS/NZS 4777, the inverter needs to support the function of demand response mode (DRM). With the use of an external control box, active or reactive power regulation can be realized in a timely and fast manner, and the inverter can be operated stably during the process of regulation.

DRM 0, DRM 1 and DRM 5 are available now.

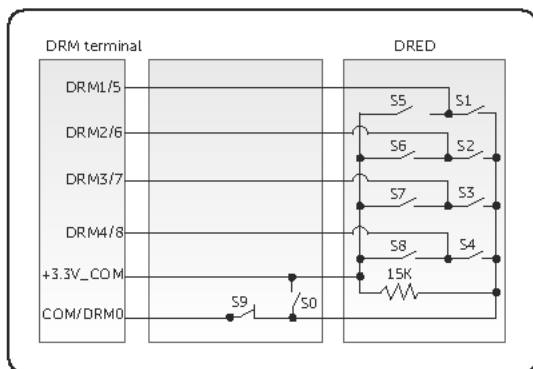

Figure 7-100 DRED connection diagram

Table 7-7 Descriptions of DRM

Mode	Pin	Requirement
DRM 0	Pin 6	<ul style="list-style-type: none"> When S0 is turned on, the inverters shut down. When S0 is turned off, the inverters restore grid connection.
DRM 1	Pin 1	<ul style="list-style-type: none"> When S1 is turned on, the inverters do not input active power.
DRM 5	Pin 1	<ul style="list-style-type: none"> When S5 is turned on, the inverters do not output active power.

- Wiring procedure

- Step 1:** Loosen the screws on the COM 1 terminal. Pinch the tabs on the sides of the COM 1 connector enclosure and pull it at the same time to remove it.
- Step 2:** Anti-clockwise loosen the swivel nut and pull out the sealing plugs. Keep them still in the cable support sleeve if you choose not to connect the cable.
- Step 3:** Thread the cable through the swivel nut, cable support sleeve, and connector enclosure in sequence.
- Step 4:** Install the network cable of the crimped RJ45 terminal to RS485 of cable clamp according to the labeling.

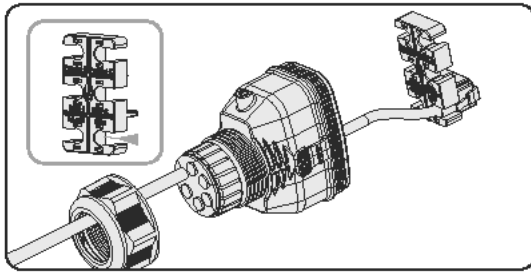

Figure 7-101 Installing RJ45 terminal to the cable clamp

- Step 5:** Connect the assembled connector to COM 1 terminal. Make sure the cable clamp tongue is well inserted into the slot of terminal. You will hear an audible "Click" if it is connected securely. Lightly pull the cable backward for double check its connection.
- Step 6:** Secure the assembled connector on COM 1 terminal.
- Install the connector enclosure back into the COM 1 terminal.
 - Install the cable support sleeve into the enclosure.
 - Tighten M3 screw to secure it. (Torque: 1.2 ± 0.1 N·m)
 - Clockwise tighten the swivel nut to finish the COM 1 wiring connection.

7.3.7 COM 2 Communication Connection

Pin assignment of COM 2 terminal

The COM 2 terminal is used for Meter/CT connection, ripple control and DIO function.

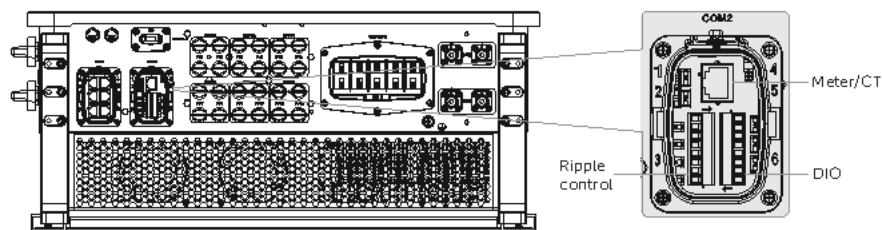

Table 7-8 Pin assignment of COM 2 terminal

Pin	Pin assignment
Meter/CT	
1	CT_R1_CON
2	CT_S1_CON
3	CT_T1_CON
4	METER_485A
5	METER_485B
6	CT_T2_CON
7	CT_S2_CON
8	CT_R2_CON
Ripple control	
1	RP_K4
2	GND_COM
3	RP_K3
4	GND_COM
5	RP_K2
6	GND_COM
7	RP_K1

Pin	Pin assignment
8	GND_COM
DIO port	
1	DO_1
2	DO_2
3	DI_1+
4	DI_1-
5	DI_2+
6	DI_2-
7	GND_COM
8	EPSBOX_RELAY_VCC

Meter/CT connection

The inverter should work with an electric meter or current transformer (CT for short) to monitor household electricity usage. The electricity meter or CT can transmit the relevant electricity data to the inverter or platform.

CAUTION!

- The inverter will shut down and prompt **Meter Fault** alarm if meter is not connected to inverter. Smart meters must be authorized by our company. Unauthorized meter may be incompatible with the inverter. SolaX will not be responsible for the impact caused by the use of other appliances.

NOTICE!

- Do not place the CT on the N wire or ground wire.
- Do not put CT on the N line and L line at the same time.
- Do not place the CT on the side where the arrow points to the inverter.
- Do not place the CT on non-insulated wires.
- The cable length between CT and inverter should not exceed 10 meters.
- It is recommended to wrap the CT clip around in circles with insulating tape.

Table 7-9 Meter/CT pin definition

	Pin	Pin assignment
For CT connection	1	CT_R1_CON
	2	CT_S1_CON
	3	CT_T1_CON
For Meter connection	4	METER_485A
	5	METER_485B
For CT connection	6	CT_T2_CON
	7	CT_S2_CON
	8	CT_R2_CON

• Wiring procedure

Step 1: Loosen the screws on the COM 2 terminal. Pinch the tabs on the sides of the COM 2 connector enclosure and pull it at the same time to remove it.

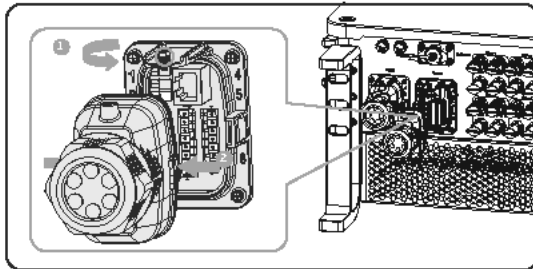

Figure 7-102 Disassembling the COM 2 terminal

Step 2: Loosen the swivel nut and pull out the sealing plugs. Keep them still in the cable support sleeve if you choose not to connect the cable.

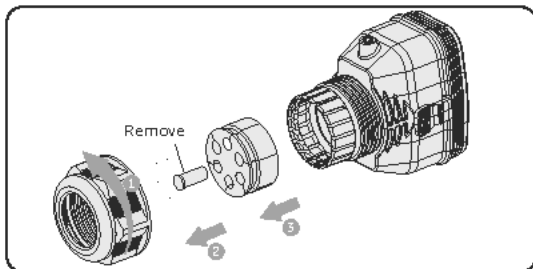

Figure 7-103 Disassembling the connector

Step 3: Directly thread the cable through the swivel nut, cable support sleeve and connector enclosure in sequence.

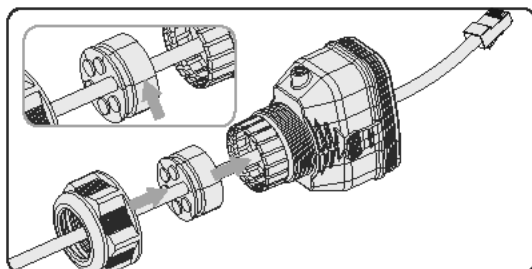

Figure 7-104 Threading the cable with RJ45 terminal

NOTICE!

- Use network cable tester to test the crimped cable before connection.

Step 4: Connect the assembled communication cable into the COM 2 terminal. Secure the assembled connector on COM 2 terminal.

- Install the connector enclosure back into the COM 2 terminal.
- Install the cable support sleeve into the enclosure.
- Tighten M3 screw to secure it. (Torque: 1.2 ± 0.1 N·m)
- Clockwise tighten the swivel nut to finish the COM 2 wiring connection.

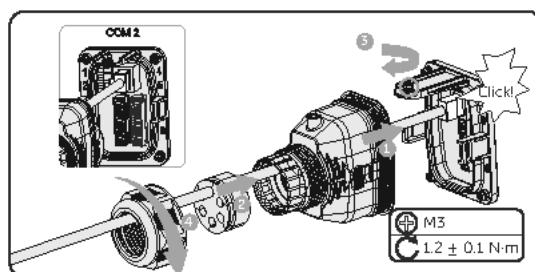

Figure 7-105 Connecting to COM 2

Step 5: For a meter connection, insert another side of the communication cable into meter. For CT connection, connect the other side to CT (part X5).

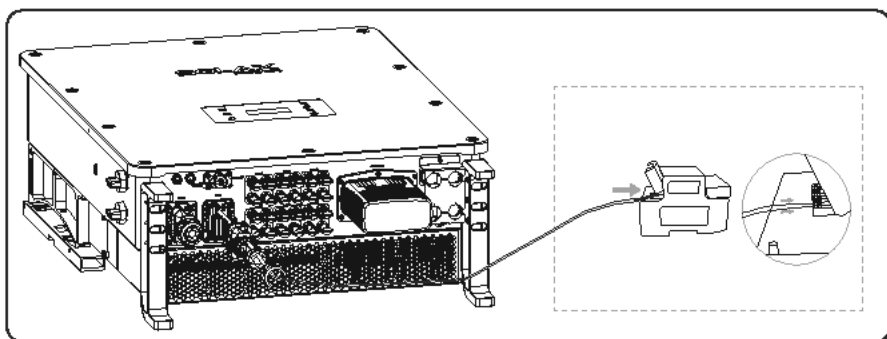

Figure 7-106 Connecting to wire meter

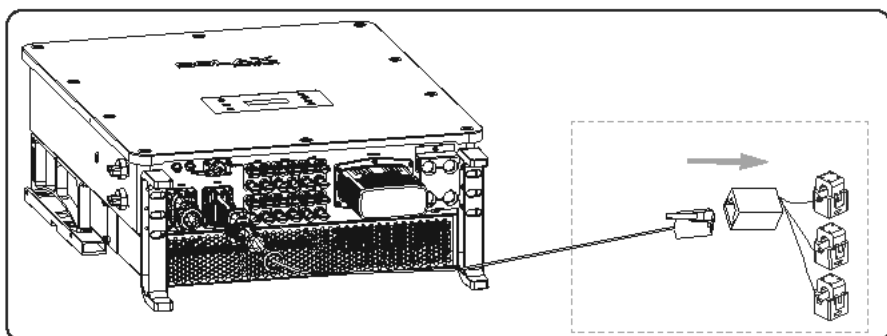

Figure 7-107 Connecting to CT

Ripple control communication connection

Ripple Control is a common form of grid management. Its communication is based on superimposing a very high frequency signal onto the 50 / 60 Hz mains power. The inverter supports to connect a digital signal source (e.g. ripple control receiver) to the digital input.

- Requirements for Ripple control
 - » The signal source must be technically suitable for connection to the digital inputs. (see technical data)
 - » The connected digital signal source has a safe separation to the grid potential.
- Connection diagram for ripple control

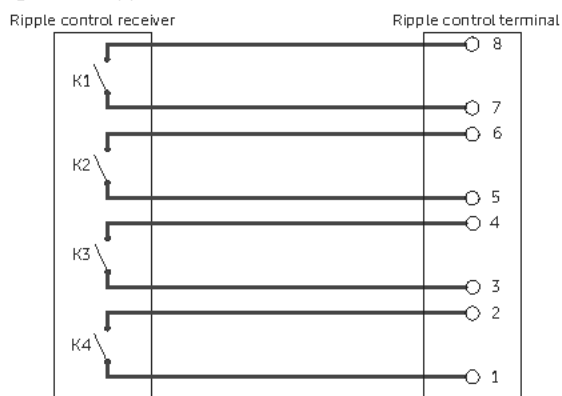

Figure 7-108 Connection diagram for ripple control

- Wiring procedure

Step 1: Loosen the screws on the COM 2 terminal. Pinch the tabs on the sides of the COM 2 connector enclosure and pull it at the same time to remove it.

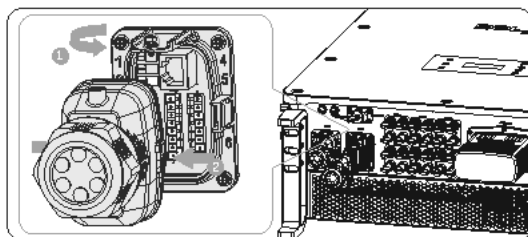

Figure 7-109 Disassembling the COM 2 terminal

Step 2: Loosen the swivel nut and pull out the sealing plugs. Keep them still in the cable support sleeve if you choose not to connect the cable.

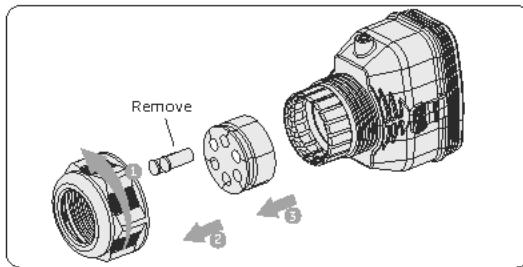

Figure 7-110 Disassembling the connector

Step 3: Prepare two four-core signal cables. Thread the cables through the swivel nut, cable support sleeve, and connector enclosure in sequence.

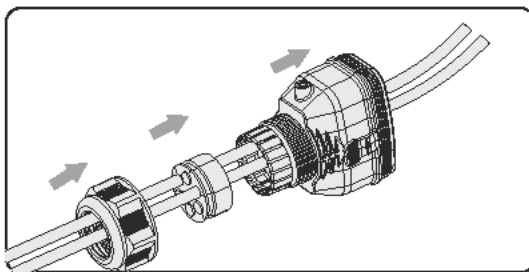

Figure 7-111 Threading the cables

Step 4: Strip approx. 6 mm of the cable insulation. Insert the conductors into the 8-pin terminal block (part F5) and tighten the terminal block screws. (torque: 0.2 ± 0.1 N.m) Ensure that the conductors are firmly seated in the terminal.

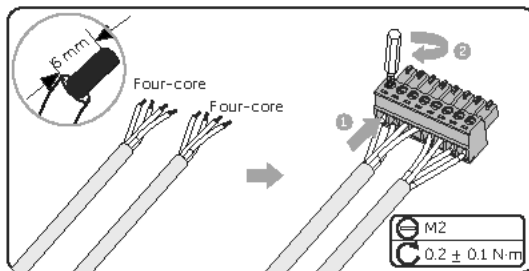

Figure 7-112 Connecting to 8-pin terminal block

Step 5: Connect the assembled communication cable into the COM 2 terminal. Lightly pull the cable backward to confirm tight insertion and then install the connector back.

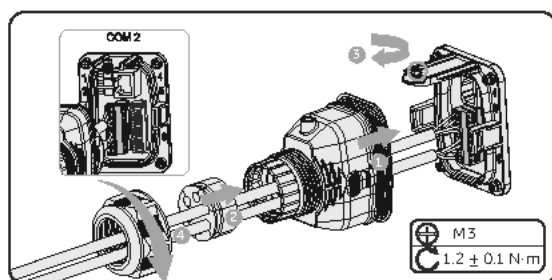

Figure 7-113 Connecting to the inverter

DIO communication connection

DIO terminal is designed to support generator and system switch connection through dry contact.

To enhance safety and reduce the risk of injury, you can install the system switch in a readily accessible location through dry contact connection. In the event of an emergency, the system switch can be easily reached and pressed to promptly switch off the entire system, ensuring a swift response and preventing further harm.

For generator, please refer to corresponding manual for specific application.

Table 7-10 DIO pin definition

	Pin	Pin assignment
For generator dry contact output	1	DO_1
	2	DO_2
For system switch dry contact input	3	DI_1+
	4	DI_1-
Reserved	5	DI_2+
	6	DI_2-
Reserved	7	GND_COM
For power supply	8	EPSBOX_RELAY_VCC

NOTICE!

- If there is strong interference in the surroundings, it is recommended to use shielding cables and ground the shielding layer of the cables through Pin 7.

- System switch connection diagram

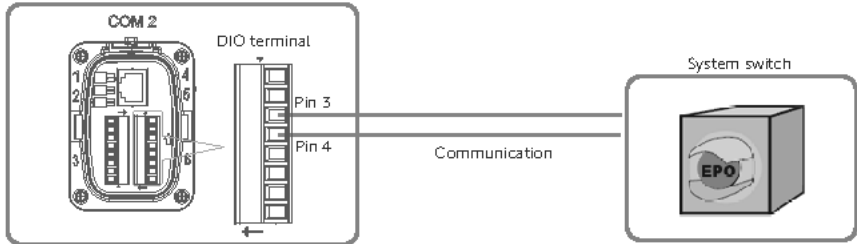

Figure 7-114 System switch connection diagram

Choose a self-locking switch for the system. When system switch is pressed, **OFF MODE (DIO SW)** will be displayed on the LCD screen and the system will be powered off. To release the switch, press it again.

- Wiring procedure

- Step 1:** Loosen the screws on the COM 2 terminal. Pinch the tabs on the sides of the COM 2 connector enclosure and pull it at the same time to remove it.
- Step 2:** Loosen the swivel nut and pull out the sealing plugs. Keep them still in the cable support sleeve if you choose not to connect the cable.
- Step 3:** Prepare two four-core signal cable. Thread the cables through the swivel nut, cable support sleeve, and connector enclosure in sequence.
- Step 4:** Strip approx. 6 mm of the cable insulation. Insert the conductors into the 8-pin terminal block and tighten the terminal block screws. (torque: 0.2 ± 0.1 N·m) Ensure that the conductors are firmly seated in the terminal.

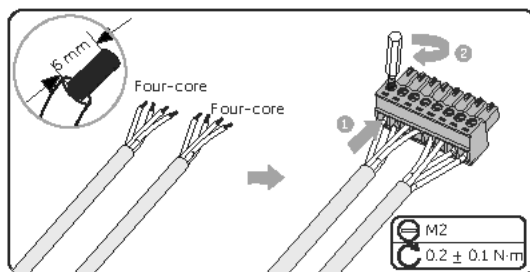

Figure 7-115 Connecting to 8-pin terminal block

- Step 5:** Connect the assembled communication cable into the COM 2 terminal. Lightly pull the cable backward to confirm tight insertion and then install the connector back.

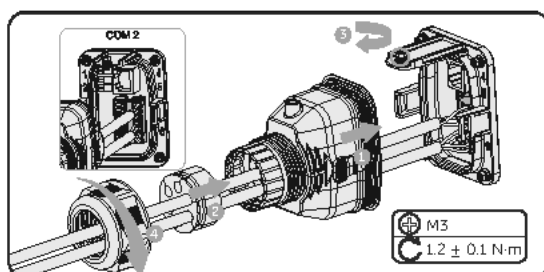

Figure 7-116 Connecting to the inverter

7.3.8 Monitoring Connection

The inverter provides a DONGLE terminal, which can transmit data of the inverter to the monitoring website via WiFi+Lan dongle (Optional). The WiFi+Lan dongle is equipped with two kinds of communication modes (Wi-Fi mode or LAN mode). Users can choose based on actual needs. (If needed, purchase products from us.)

Monitoring connection diagram

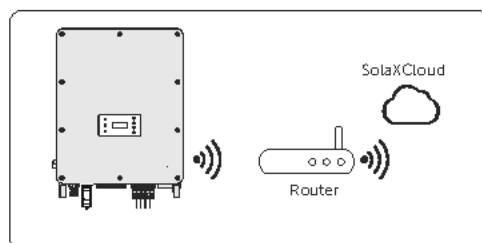

Figure 7-117 Wi-Fi mode connection diagram

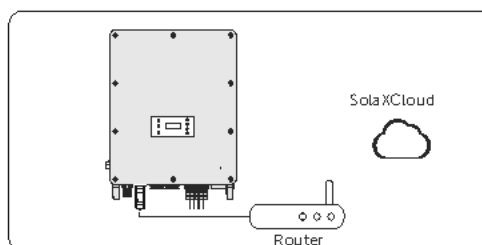

Figure 7-118 LAN mode connection diagram

Monitoring wiring procedure

Wi-Fi mode:

- a. Assemble the dongle,.

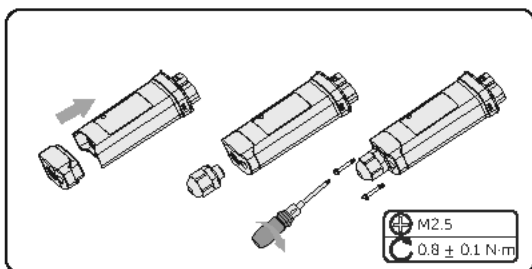

Figure 7-119 Assembling the dongle

- b. Plug the dongle to the inverter

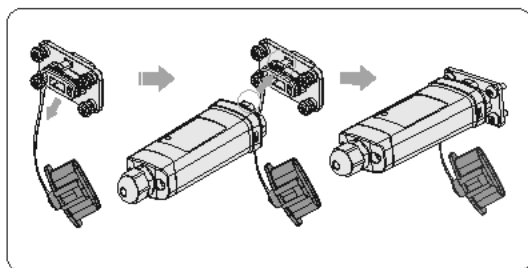

Figure 7-120 Wi-Fi connection procedure

⚠ CAUTION!

- The buckles on the inverter and dongle must be on the same side. Otherwise, the dongle may be damaged.

NOTICE!

- The longest connection distance between the router and the equipment should be no more than 100 meters; if there is a wall between the router and the equipment, the longest connection distance is 20 meters.
- When the Wi-Fi signal is weak, please install a Wi-Fi signal booster at the appropriate location.

NOTICE!

- Please refer to "Pocket WiFi + LAN Installation Guide" for instructions on configuring the Wi-Fi. It is important to note that the Wi-Fi configuration should be performed after powering on the inverter.

LAN mode:

- Disassemble the waterproof connector into components **1**, **2**, **3** and **4**; Component **1** is not used. Keep it in a safe place.

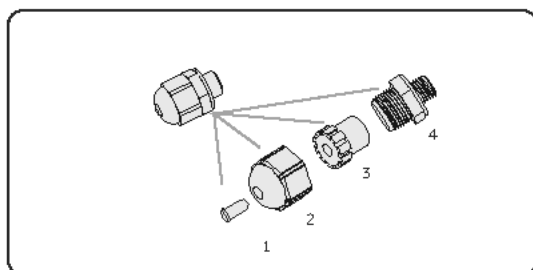

Figure 7-121 Disassembling the waterproof connector

- Assemble the dongle.

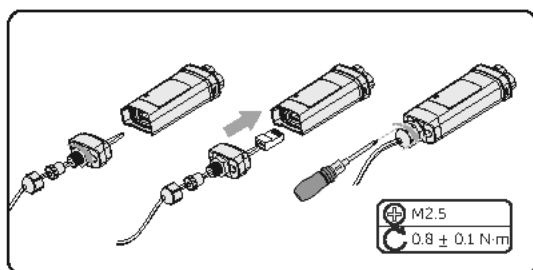

Figure 7-122 Assembling the LAN dongle

- Plug the dongle to the inverter.

8 System Commissioning

8.1 Checking before Power-on

- Check the devices installed correctly and securely;
- Make sure that all the BAT BUTTON, BAT SWITCH, DC breakers and AC breakers are OFF;
- All cables are connected correctly and securely;
- Unused terminals and ports are locked by waterproof caps;
- All photovoltaic panels are connected correctly and securely.

8.2 Powering on the System

Step 1: Gently flip up breaker.

Step 2: Rotate the disconnecter of the high-voltage box to "ON". At the point, the LED light will come on green.

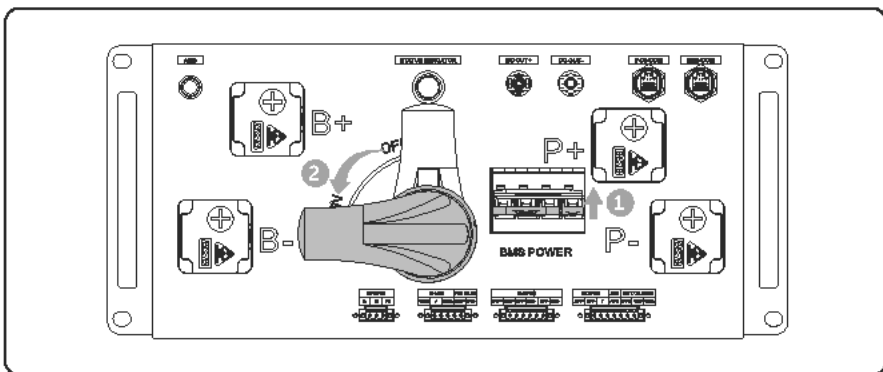

Figure 8-1 Turn off breaker and disconnecter

- Step 3:** Hold and press the button on the high-voltage box for 10 seconds to assign each battery pack in a communication loop a unique address (battery number). The LED light fast flashes green during the address assignment period, and then turns to solid green after completing the address assignment.

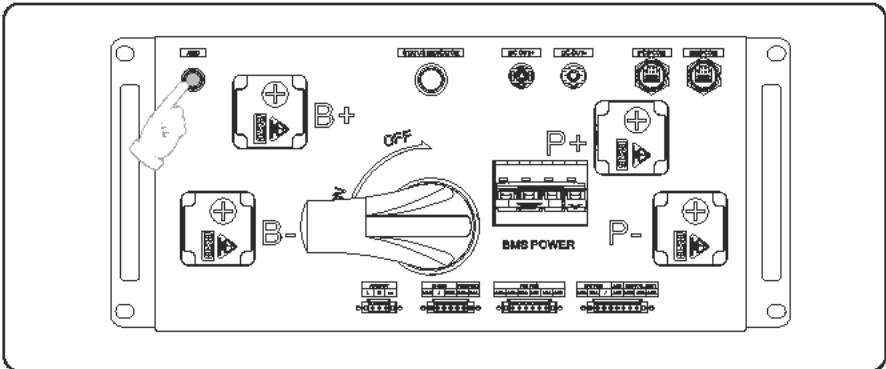

Figure 8-2 Hold and press the button

- Step 4:** Turn on the AC breakers and check whether the LCD screen lights on.
- » If the LCD screen is not on, turn off the AC breakers and check whether the Grid cable is connected correctly and securely.
- Step 5:** Switch on the inverter DC switch and check the LCD screen, refer to "PV status" to check the PV voltage.

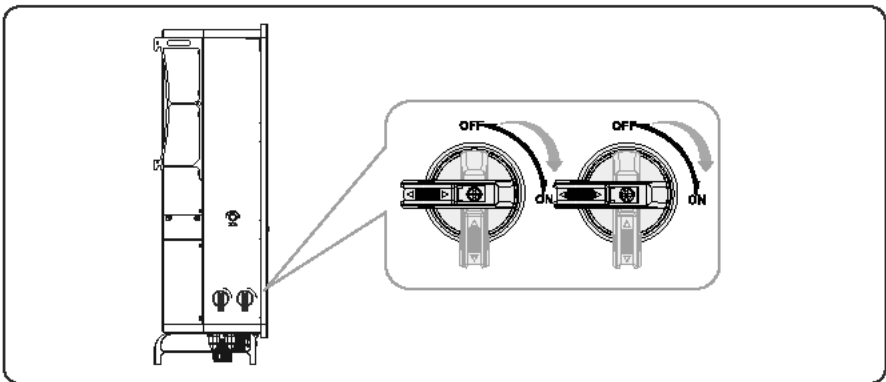

Figure 8-3 Turn on DC switch

- » If the PV voltage is 0, turn off the the DC switch, pull out the PV connectors and then measure the voltage of the positive and negative PV port (in MPPT voltage range 160-950 V) or check whether the positive and negative poles of PV cables are reversed.

Step 6: Press and turn on the inverter system button.

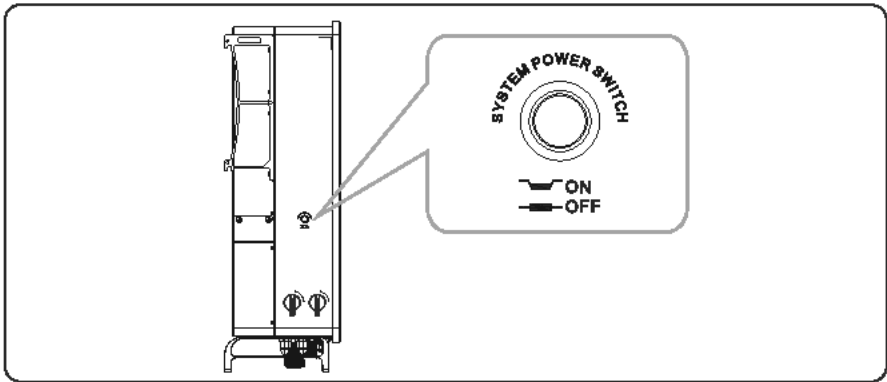

Figure 8-4 Turn on the inverter system

Step 7: Set "System ON/OFF" as ON status on the inverter screen, and the LCD displays waiting status.

Step 8: When the photovoltaic panels generate enough power or the battery supplies power, the inverter will start automatically. The inverter will go Waiting, Checking and Normal status in sequence.

Step 9: Check whether the meter/CT is correctly connected.

- » If CT is connected, please perform the Meter/CT Check to check the correct connection through the setting path: **Menu>Setting>Advance Setting>Meter/CT Settings>Meter/CT Check**
- » If meter is connected, please set the connection of Meter through the setting path: **Menu>Setting>Advance Setting>Meter/CT Settings.**

NOTICE!

- When the meter or CT is correctly connected, the meter/CT power displays on the METER/CT check interface; when the connection method is wrong, "Meter Fault" displays on this interface.

8.3 Checking after Powering on

- a. Check whether the system has any abnormal noise.
- b. Check whether the indicator lights report an error and whether the LCD screen displays the error message.
- c. Check whether the data of PV, grid and battery are normal in the LCD screen.
- d. Check whether the Work Mode is consistent with what had been set through LCDscreen or the SolaXCloud App.

8.4 Operation of Lockable DC Switch (for Australia Version Only)

NOTICE!

- The Australian version DC switch is a lockable DC switch to prevent accidental switching on during maintenance, the lock needs to be prepared by the user.

The lockable DC switch includes 3 states: ON, OFF, and OFF+Lock. The DC switch is in the OFF state by default.

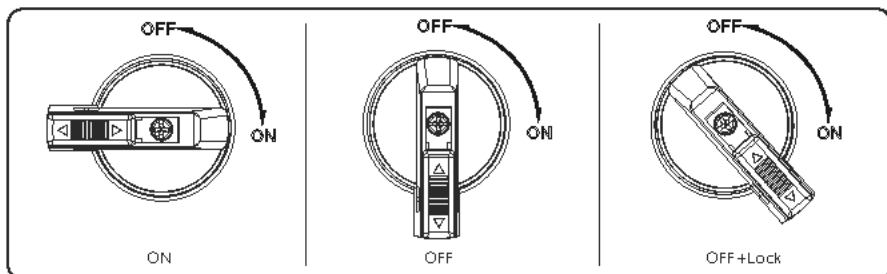

- Turn on the DC switch: rotate the DC switch from OFF state to ON state.

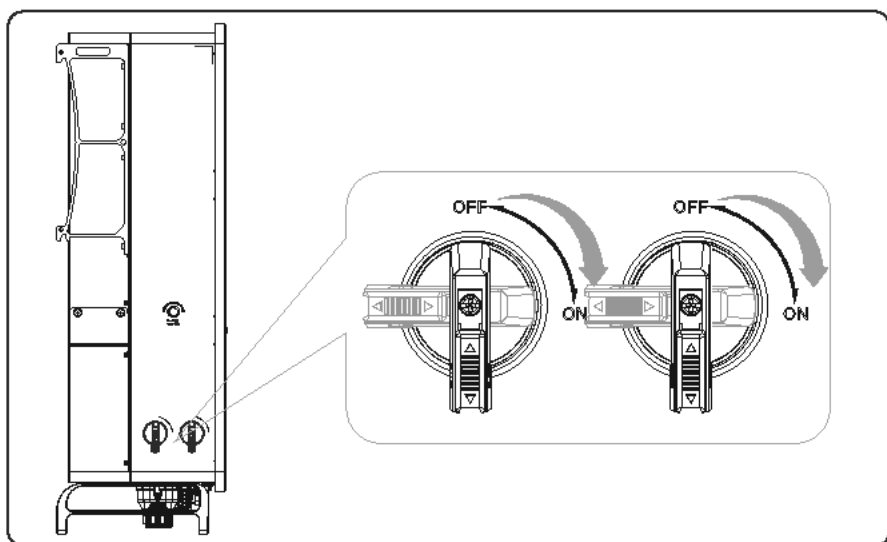

- Turn off the DC switch: rotate the DC switch from ON state to OFF state.

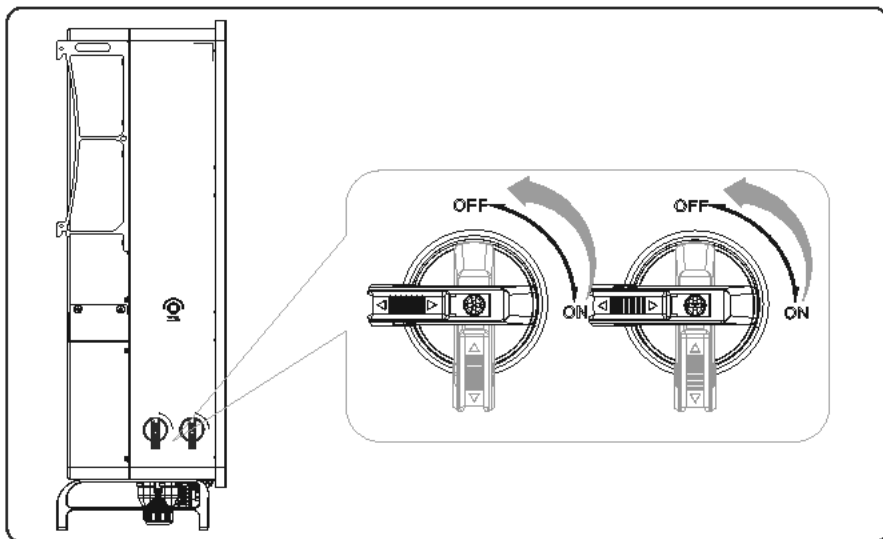

- Lock the DC switch
 - a. Rotate the DC switch to OFF state, then rotate the DC switch to the left side;
 - b. Push the position indicated by the arrow upward (as shown in the diagram below).
 - c. (Optional) After pushing the position upward, choose to lock the DC switch with a lock.

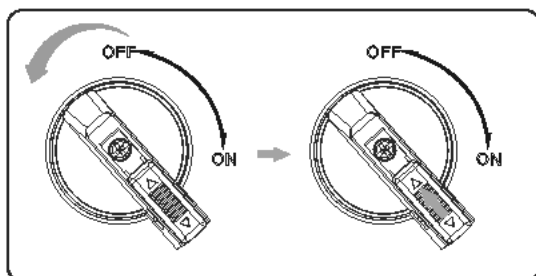

- Unlock the DC switch
 - a. Remove the lock. (If any);
 - b. Push the position indicated by the arrow down (as shown in the diagram below);
 - c. Wait for it to return to OFF state.

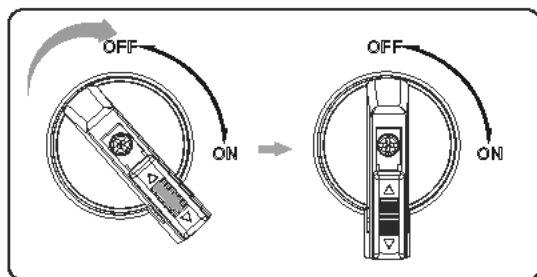

9 Operation on LCD

9.1 Introduction of Control Panel

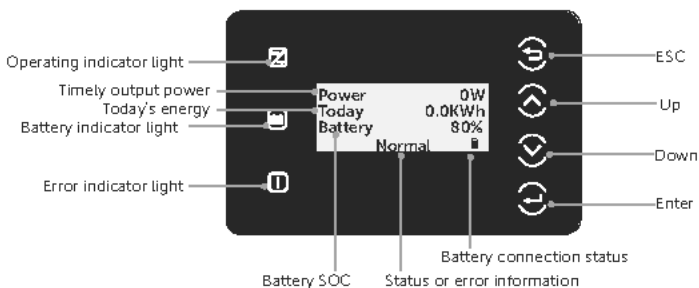





Figure 9-1 Control Panel

- In a normal state, the "Power", "Today" and "Battery" information will be displayed. You can press the keys to switch information.
- In an error state, the fault message and error code will be displayed, please refer to "11.2 Troubleshooting" for corresponding solutions.

Table 9-1 Definition of keys

Key	Definition
 ESC key	Exit from the current interface or function
 Up key	Move the cursor to the upper part or increase the value
 Down key	Move the cursor to the lower part or decrease the value
 Enter key	Confirm the selection

9.2 Introduction of Menu Interface

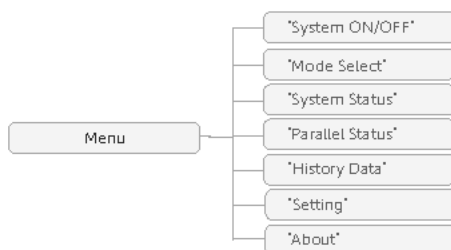

There are seven submenus in the menu that can be selected for relevant setting operations.

- **System ON/OFF:** Switch on and off the inverter.
- **Mode Select:** Select the working mode of the inverter, including **Self Use, Feed-in Priority, Backup Mode, Manual, Peaking Shaving** and **TOU Mode**.

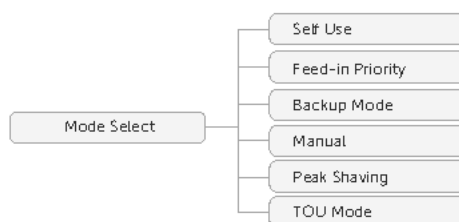

- **System Status:** Display the real-time value of PV, battery, etc. Including **PV1, PV2, PV3, PV4, PV5, PV6, Battery 1, Battery 2, On-grid, EPS** and **Meter/CT**.

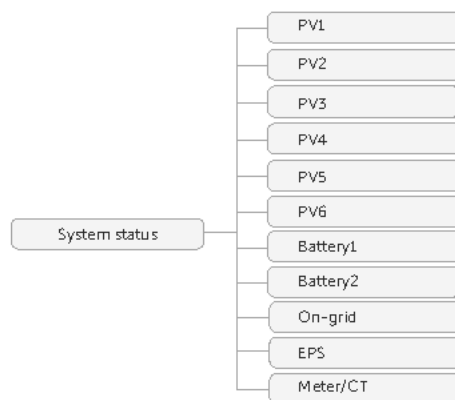

- **Parallel Status:** Display all the status data from master inverter when the inverters are parallel-connected.
- **History Data:** Display the history data of **On-grid, EPS, E_Feedin, E_USERDEF**

and **Error Log**.

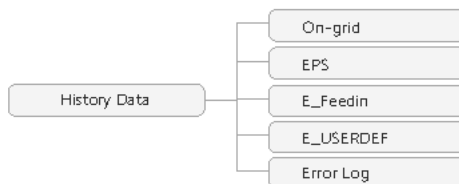

- **Setting:** Set the parameters of inverter, including **User Setting** and **Advance Setting**.

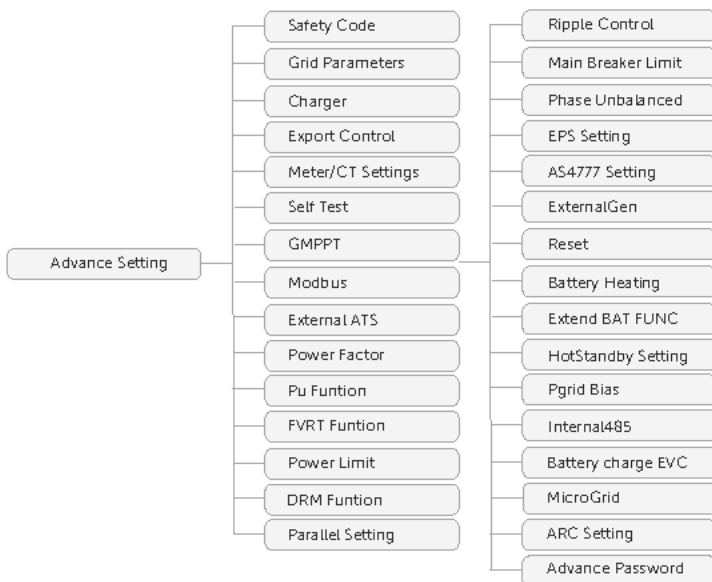
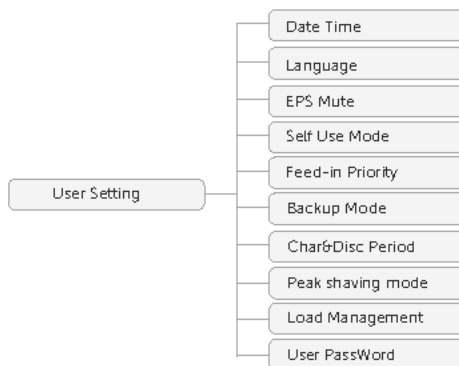

- **About:** Display the information about **Inverter**, **Battery 1**, **Battery 2**, **ACR Clear** and **Internal code**.



9.3 System ON/OFF

Setting path: **Menu>System ON/OFF**

Select **ON** or **OFF** to switch on and off the inverter. The interface is displayed **ON** by default. When you select **OFF**, the inverter stops running and display **System OFF**.

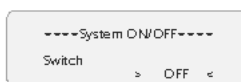

9.4 Mode Select

Selecting path: **Menu>Mode Select**

Here you can only select the working mode. Six working modes are available for you to choose in on-grid status, i.e Self-use mode, Feedin Priority, Backup, Peak shaving mode, TOU Mode and Manual. You can choose the working modes according to your lifestyle and environment. Please refer to "2.7 Working Mode" for introduction of the modes and "10.8.1 User Setting" for specific setting of each mode.

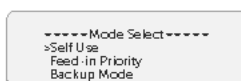

9.5 System Status

Displaying path: **Menu>System Status**

After entering into the **System Status** interface, the status of PV, Battery, On-grid, EPS, Meter/CT will be displayed on the LCD as follows:

- PV status: You can see information of **PV1**, **PV2**, **PV3**, **PV4**, **PV5** and **PV6**. Information contains input voltage, current and power of each PV. For X3-AELIO-50K and X3-AELIO-49.9K inverter, the value of **PV6** is 0.



- Battery status: There will be information of **Battery1** and **Battery2** displayed here. It shows the status of each battery terminal, including the voltage, current, power, SOC, temperature and BMS connection status. Positive value with current and power means charging; Negative value means discharging.



- On-grid status: Information contains the voltage, current, frequency, and output power of **Grid** terminal. The "A", "B" and "C" in On-grid A, On-grid B and On-grid C refers to L1, L2 and L3 respectively. The figure below will take On-grid A as an example.



- EPS status: Information contains apparent power, voltage, current, active power and frequency of **EPS** terminal when it is disconnected from the grid. The "A", "B" and "C" in EPS A, EPS B and EPS C refers to L1, L2 and L3 respectively. The figure below will take EPS A as an example.

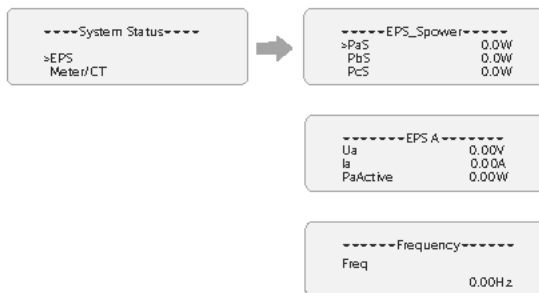

- Meter/CT status: Information contains feed-in power of L1, L2 and L3 detected by the connected meter or CT.



9.6 Parallel Status

Displaying path: **Menu>Parallel Status**

NOTICE!

- Once inverter enters parallel system, the **Today** yield will be replaced by **Parallel**.

In **Parallel Status** interface, the whole system power and individual slave inverter power can be obtained in **Parallel Status** interface of master inverter. The number displayed in the **Parallel Status** interface refers to the total number of online inverters, for example two inverters in parallel in the below figure.

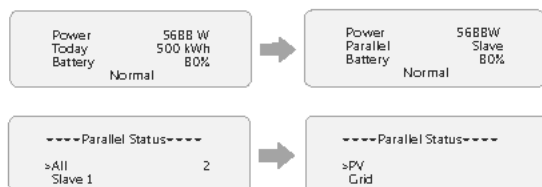

9.7 History Data

Displaying path: **Menu>History Data**

After entering into the **History Data** interface, the status of **On-grid**, **EPS**, **E_Feedin**, **E_USERDEF**, **Error Log** will be displayed on the LCD as follows:

- On-grid**: A record of the output and input electric energy of inverter from grid today and the total. (through **Grid** terminal)
 - » **Output Today**: Output electric energy of inverter today.
 - » **Output Total**: Total output electric energy since the inverter activated for the first time.
 - » **Input Today**: Input electric energy of inverter today.
 - » **Input Total**: Total input electric energy since the inverter activated for the first time.

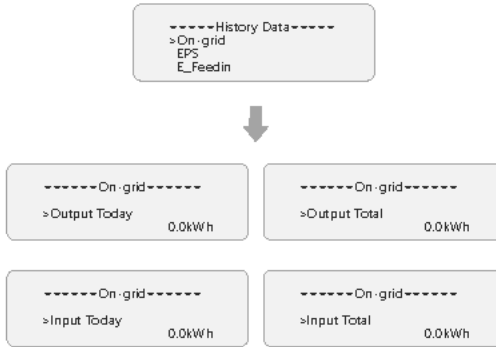

- **EPS:** A record of the output electric energy of the inverter today and the total when it is disconnected from grid. (through **EPS** terminal)

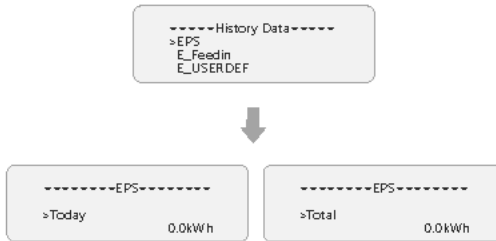

- **E_Feedin:** The total electricity fed into or taken from the grid since the inverter activated for the first time and on that day. (detected by Meter/CT)
 - » **Feedin Today:** Electricity sold to grid today.
 - » **Feedin Total:** Total electricity sold to grid since the inverter activated for the first time.
 - » **Consume Today:** Electricity bought from grid today.
 - » **Consume Total:** Total electricity bought from grid since the inverter activated for the first time.

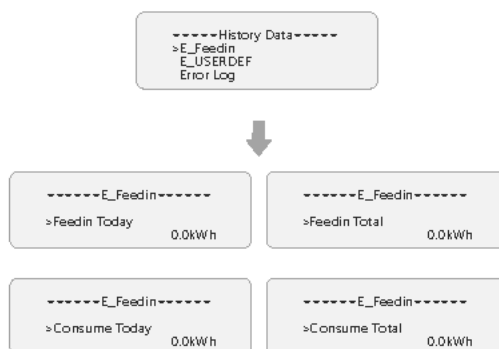

- **E_USERDEF:** The output electricity of the connected on-grid inverter today and the total.(detected by Meter 2) This function is only available when meter 2 is connected.

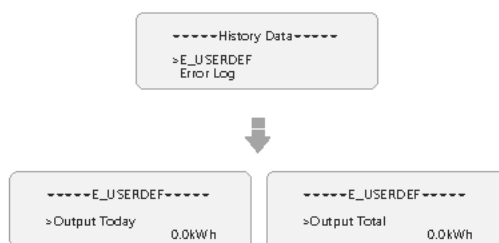

- **Error Log:** Display the recent six error messages. Information contains date and time error happened, error code and error description.



9.8 Setting

Settings includes User Settings and Advanced Settings.

9.8.1 User Setting

Setting path: **Menu>Setting ("0 0 0 0 ")>User Setting**

NOTICE!
The default password for User Setting is "0 0 0 0".

Setting Date & Time

You can set the current date and time of the installation site.

The display format is "2023-06-16 14:00", in which the first four numbers represent the year (e.g. 2000~2099); the fifth and sixth numbers represent the month (e.g. 01~12); the seventh and the eighth numbers represent the date (e.g. 01~31). The remaining numbers represent the time.



Setting Language

This inverter provides multiple languages for customers to choose, such as English, Deutsch, francais, Polskie, Espanol, Portugués. The default language is English.



Setting EPS Mute

When the inverter is running in EPS Mode, you can choose whether the buzzer is turned on or not.

- Select **Yes**, the buzzer mutes.
- Select **NO**, the buzzer will sound once every 4 seconds if the battery SOC is > EPS min. SOC. When the battery SOC is equal to EPS min SOC, the buzzer will sound with higher frequency at every 400 ms. And turn off the sound when the battery SOC is < EPS min SOC. This function is turned off by default.



Setting Self Use Mode

Please refer to "2.7.1 Self-use Mode" for working logic of this mode.

- **Min SOC:** Default: 10%; range: 10%~100%
 - » The minimum SOC of the battery. The battery will not discharge power when the SOC of the battery reaches this value.



- **Charge from grid:**
 - » You can set whether the power can be taken from the grid to charge the battery. When **Charge from grid** is set to **Enable**, the utility power is allowed to charge the battery; when it is set to **Disable**, the utility power is not allowed to charge the battery.



- **Charge battery to:** Default: 10%; range: 10%~100%
 - » Set the SOC to charge the battery from grid (applicable only when the **Charge from grid** is enabled).
 - » You can set your own target value, i.e. during the forced charging period, the inverter will use both PV & GRID energy to charge the battery SOC to the target SOC value, after the battery SOC meets the target value, if the PV energy is still sufficient (enough for load and there is excess power), the inverter will continue to use PV energy to charge the battery.

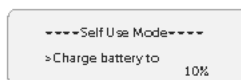

Setting Feed-in Priority

Please refer to "2.7.2 Feed-in Priority" for working logic of this mode.

- **Min SOC:** Default: 10%; range: 10%~100%
 - » The minimum SOC of the battery. The battery will not discharge power when the SOC of the battery reaches this value.



- **Charge battery to:** Default: 50%; range: 10%~100%
 - » Set the SOC to charge the battery from grid.
 - » You can set your own target value, i.e. during the forced charging period, the inverter will use both PV & GRID energy to charge the battery SOC to the target SOC value, after the battery SOC meets the target value, if the PV energy is still sufficient, the surplus power will be fed into the grid.

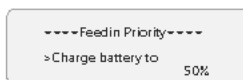

Setting Backup Mode

Please refer to "2.7.3 Backup Mode" for working logic of this mode.

- **Min SOC:** Default: 30%; range: 30%~100%
 - » The minimum SOC of the battery. The battery will not discharge power when the SOC of the battery reaches this value.



- **Charge battery to:** Default: 50%; range: 30%~100%
 - » In this mode, the charge from grid function is turned on by default, and customers can set the target value by themselves, that is, during the forced charging period, the inverter will cooperate with PV&GRID to charge the battery to the target value. if the PV energy is still sufficient (enough for load and there is excess power), the inverter will continue to use PV energy to charge the battery.

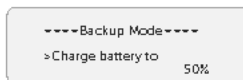

Setting Char&Disc Period

NOTICE!

- The charging and discharging period is only applicable for self-use mode, feed-in priority and backup mode.

Here you can set the **Forced Charge Period** and **Allowed Disc Period**.

If two charging and discharging periods are needed, enable the **Function Control** to activate the **Char&DischrgPeriod2**.

- **Char&Disc Period:** You can set the charge and discharge time according to your own needs. The default time axis of the system is 24h.
 - » **Forced Charge Period Start Time:** Time to start charging; default:00:00; range: 00:00~23:59
 - » **Forced Charge Period End Time:** Time to stop charging; default:00:00; range: 00:00~23:59
 - » **Allowed Disc Period Start Time:** Time allows to start discharging (The charging or discharging of the battery depends on the work mode.) default:00:00; range: 00:00~23:59
 - » **Allowed Disc Period End Time:** Time to stop discharging; default:23:59; range: 00:00~23:59



- **Char&Disc Period2:** The second time axis is closed by default. If two charging and discharging periods are needed, turn on the charging and discharging period 2. This period will hold the same setting logic as **Char&Disc Period**.

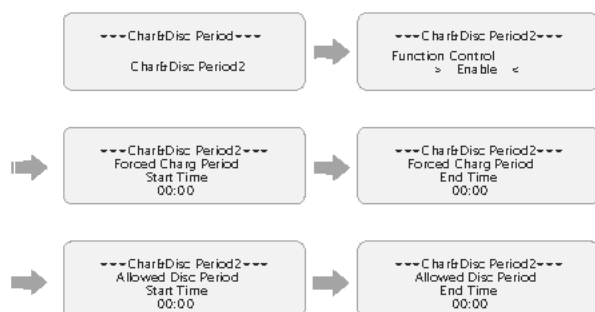

Setting Peak shaving mode

- **DisChgPeriod1:** To set **ShavingStartTime**, **ShavingEndTime** and **PeakLimits**. **DisChgPeriod1** can be regarded as Peak shaving period. This period should be set to cover load peaks. Battery will be discharged to shave load peak until battery SOC drops to **Min SOC** (10% by default)

- » **PeakLimits1:** Default:0 W, range: 0-60000 W

Once the consumption (grid side) reaches this value, the inverter will start shaving to keep the consumption lower than this value.

- » **ShavingStartTime:** Default: 7:00

The battery starts discharging to shave consumption from the set time.

- » **ShavingEndTime:** Default: 15:00

The battery stops discharging at the set time.

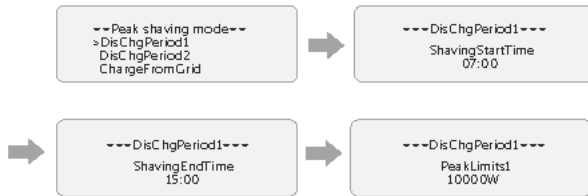

- **DisChgPeriod2:** Same working logic with DisChgPeriod1

- » **PeakLimits2:** Default:0 W, range: 0-60000 W

- » **ShavingStartTime:** Default: 19:00

The battery starts discharging to shave consumption from the set time.

- » **ShavingEndTime:** Default: 23:00

The battery stops discharging at the set time.

- **ChargeFromGrid:** It can be used in specific time period. This period allows inverter to take energy from grid to charge battery in order to have enough backup for peak shaving. Please note that this period starts from ShavingEndTime2, end until ShavingStartTime1.

- » **Enable:** Activate the function of **ChargeFromGrid** to allow the inverter taking grid energy to charge battery. The **ChargePowerLimits** and **MAX_SOC** will be displayed only when **ChargeFromGrid** is enabled.

- » **ChargePowerLimits:** Default: 1000 W; range: 0-60000 W

Settable target power taken from grid. Inverter will use this target power taken from grid to charge battery.

- » **MAX_SOC:** Default: 50%; range: 10%-100%

Inverter will take grid energy to charge battery until battery SOC reaches this value.



- **Reserved_SOC**: Default: 50%; range: 10%-100%
 - » It can be used in specific time period. In this period, inverter does not allow taking grid energy to charge battery. PV is the only way to charge battery and PV will charge the battery first. Inverter will not supply power to loads until battery SOC higher than this value in order to save enough energy for later shaving period.



Setting Load Management

To use the heat pump function, you need to set the relevant parameters on LCD screen. This function is applicable for the first generation of SolaX Adapter Box.

- a. Enter the **Load Management** interface through the path: **Menu>Setting>User Setting>Load Management**
- b. Set the **Load Management** mode. Overall three heat pump operation modes are available for you to choose:

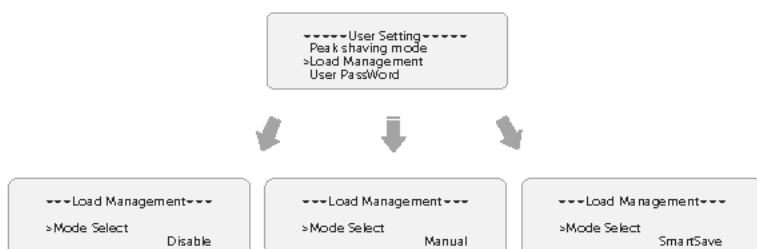

- » **Mode 1 Disable**: The Adapter Box function is disabled under this operation mode.
- » **Mode 2 Manual**: In this operating mode, you can change the Adapter Box from on to off, or from off to on through settings on the inverter or through SolaX App.
- » **Mode 3 SmartSave**: In this operating mode, users can set a series of parameters on the SolaX inverter to intelligently control how and when the heat pump works for them. (see Step C)

- c. Set the parameters for mode **SmartSave**. In this mode, you can set **Thresholds on Feedin power**, **Thresholds off Consumption**, **Thresholds off Battery SOC**, **Minimum duration per on-signal**, **Minimum duration per day** and **Schedule** in accordance with your actual needs.

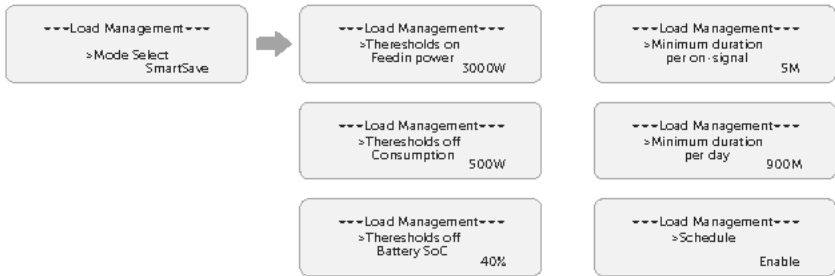

- Setting thresholds on/off
 - » **Thresholds on Feedin power**: Once the feed-in power is greater than or equal to the set value, the Adapter Box will turn on and the heat pump will heat the water up to a higher temperature.
 - » **Thresholds off Consumption**: Once the power consumption (from the grid) is greater than or equal to the set value, the Adapter Box will be turned off, SolaX system stops providing electricity to heat pump.
 - » **Thresholds off Battery SOC**: Once the battery SOC drops to the set value, the Adapter Box will turn off, SolaX system stops providing electricity to heat pump.
- Setting minimum / maximum duration
 - » **Minimum duration per on-signal**: Minimum working hours, heat pump will work at least the time set here every time it is activated. High priority than other power threshold settings.
 - » **Maximum duration per day**: Maximum working hour limitation per day. High priority than other power threshold settings.
- Setting schedule
 - » **Schedule**: Set the heat pump working periods flexibly (heat pump on and off periods). High priority than other power threshold settings. Two work periods can be set.



- Mode Priority: **Minimum/Maximum duration > Schedule > Thresholds on/off**

Setting TOU mode

TOU mode can only be set in SolaXCloud App. Aftering setting the TOU in the App, the selected TOU mode will be displayed in TOU interface on the LCD.

- **Min SOC:** The minimum SOC of the system, default: 10%



- **Charging Mode:**

- » **Self-use:** Same working logic with "Self-use Mode", but it is not limited by the charging and discharging time slots. The priority of PV: Loads > Battery > Grid. **Min SOC:** Default: 10%



- » **Feedin-priority:** Same working logic with "Feedin-priority Mode", but it is not limited by the charging and discharging time slots. The priority of PV: Loads > Grid > Battery.

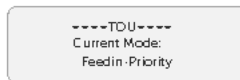

- » **Peak shaving:** The working logic is that when the power consumption from the grid exceeds the set PeakLimit value, the battery is allowed to discharge power. The excess power beyond the limit is provided by the combination of photovoltaic and battery to ensure that the maximum power purchased from the grid does not exceed the set limit. **Peaklimits:** Default: 0 W



- » **Charging:** The power of PV will charge the battery as much as possible to the set SOC of Charge BAT to (%). You can set whether to Charge from grid. The default value of Charge BAT to (%) is 100%. When the battery reaches the set SOC, the surplus power will perform "Self-use Mode" or supply to the grid (based on the system setup), at this point, Charge from grid is not allowed. **Charge from grid:** Default: Disable. **Charge BAT to:** Default: 100%

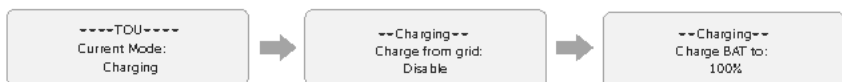

- » **Discharging:** If allowed by the battery, the system outputs a specified power from the grid based on the set output percentage, controlling the power at the AC port. You need to set the RatePower (%) through Web

or App when choosing Discharging mode. When the battery Discharge to (%) reaches the set SOC, the inverter performs "Self-use Mode".

Rate of AC Power: Default: 100%. **Discharge to:** Default: 10%.

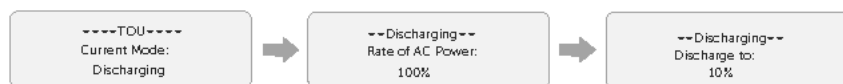

Setting User Password

The default password is "0 0 0 0". You can reset the password here.

9.8.2 Advance Setting

Setting path: **Menu>Setting>Advance Setting**

NOTICE!
<p>Property losses or system damage due to unauthorized access to adjustable parameters.</p> <ul style="list-style-type: none">• All the adjustable parameters including safety code, grid parameter, export control, etc can be modified under the permissions of installer password. Unauthorized use of the installer password by unauthorized persons can lead to incorrect parameters being input, resulting in power generation loss or violation of local regulation. Get the installer password from the dealer and never open the password to unauthorized person.

Setting Safety Code

NOTICE!
<ul style="list-style-type: none">• The inverter cannot be connected to the grid before the safety code is correctly set. If there is any doubt about your safety code where the inverter installed, please consult your dealer or SolaX service for details.• The setup will vary from different safety codes.

Here you can set safety code according to different countries and grid-tied standards.

There are several standards to choose from, please refer to the LCD screen on the inverter. (May be changed or added without notice)

- When you select safety code **CEI 0-21**, there will be additional **Self Test** option for setting under the path of **Menu>Setting>Advance Setting**.
- When you select safety code **AS4777**, there will be additional **AS4777 Setting** option for **General Control** and **Export Control** under the path of **Menu>Setting>Advance Setting**.

Setting Grid parameters

The default value is the specified value under the current safety regulations. The contents will be displayed according to the requirements of local laws and regulations. Please refer to the actual contents displayed on the LCD screen on the inverter.

-----Grid Parameters-----
 > Overvoltage
 > Undervoltage
 > OverFreq_LL

Please select Australia Region A / B / C in compliance with AS4777. Only after the safety code setting is completed, some designated parameters in the inverter system will take effect according to the corresponding safety regulations.

Region	Australia A	Australia B	Australia C	New Zealand	
Standard Code Name	AS4777_2022_A	AS4777_2022_B	AS4777_2022_C	New Zealand	Setting Range
OV-G-V	265 V	265 V	265 V	265 V	230-300 V
OV-GV1-T	1.5 s	1.5 s	1.5 s	1.5 s	
OV-G-V2	275 V	275 V	275 V	275 V	230-300 V
OV-GV2-T	0.1 s	0.1 s	0.1 s	0.1 s	
UN-G-V1	180 V	180 V	180 V	180 V	40-230 V
UNGV1-T	10 s	10 s	10 s	10 s	
UN-G-V2	70 V	70 V	70 V	70 V	40-230 V
UNGV2-T	1.5 s	1.5 s	1.5 s	1.5 s	
OV-G-F1	52 Hz	52 Hz	55 Hz	55 Hz	50-55 Hz
OVGF1-T	0.1 s	0.1 s	0.1 s	0.1 s	
OV-G-F2	52HZ	52HZ	55HZ	55HZ	50-55 Hz
OVGF2-T	0.1 s	0.1 s	0.1 s	0.1 s	
UN-G-F1	47 Hz	47 Hz	45 Hz	45 Hz	40-50 Hz
UNGF1-T	1.5 s	1.5 s	5 s	1.5 s	
UN-G-F2	47 Hz	47 Hz	45 Hz	45 Hz	45-50 Hz
UNGF2-T	1.5 s	1.5 s	5 s	1.5 s	

Region	Australia A	Australia B	Australia C	New Zealand	
Standard Code Name	AS4777_2022_A	AS4777_2022_B	AS4777_2022_C	New Zealand	Setting Range
Startup-T	60 s	60 s	60 s	60 s	15-1000 s
Restore-T	60 s	60 s	60 s	60 s	15-600 s
Recover-VH	253 V	253 V	253 V	253 V	
Recover-VL	205 V	205 V	205 V	198 V	
Recover-FH	50.15 Hz	50.15 Hz	50.15 Hz	50.15 Hz	
Recover-FL	47.5 Hz	47.5 Hz	47.5 Hz	47.5 Hz	
Start-VH	253 V	253 V	253 V	253 V	
Start-VL	205 V	205 V	205 V	198 V	
Start-FH	50.15 Hz	50.15 Hz	50.15 Hz	50.15 Hz	
Start-FL	47.5 Hz	47.5 Hz	47.5 Hz	47.5 Hz	

Setting Charger

The inverter is compatible with lithium-ion battery. You can set the charge & discharge parameters of battery.

- **Max Charge:** Maximum charging current of battery
- **Max Discharge:** Maximum discharging current of battery
- **Charger upper limit:** Default: 100%, range: 10%-100%.
 - » The maximum battery SOC when charging.

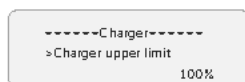
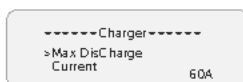
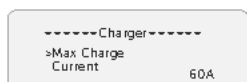

Setting Export Control

This function allows the inverter to control the amount of electricity output to the grid. The **User Value** set here must be less than the maximum value. If the user does not want to supply power to the grid, set **User Value** to "0".

NOTICE!

- Under Safety Code AS4777, **Export Control** is in the path of **Advance Setting > AS4777 Setting**. You can set the **Soft Limit** and **Hard Limit** of **Export Control** to control the power output to grid. Please refer to section "AS4777 Setting" for details.

```

-----Export Control-----
User Value
300000W
  
```

Meter/CT Setting

Please refer to "14.6 CT/Meter Connection Scenarios" for meter/CT setting.

Setting Self Test (only for CEI 0-21)

The self test function allows users to test the following items: **Full Test**, **Ovp(59.S2) test**, **Uvp (s1) test**, **Uvp (27. s2) test**, **Ofp (81> .S1) test**, **Ufp (81 <.S1) test**, **Ufp (81> .S2) test**, **Ufp (81 <.S2) test**, **Ovp10 (59. s1) test**.

In the **Self Test** interface, the user can select **All Test** or a single test item for testing. All tests take about 6 minutes. And it will display **Success**. For a single test item, it takes about a few seconds or minutes.

Before testing, make sure that the inverter is connected to the grid. Click **Test Report** to view the test results of all items.

```

-----Self Test-----
>All Test
Test Report
Ovp(59.S2) test
  
```

Setting GMPPT

You can set the shadow tracking speed with four options, which are **Off**, **Low**, **Middle**, and **High**. This function is off by default.

- Off**: Switch off the shadow tracking function.
- Low**: Scan the shadow every four hours.
- Middle**: Scan the shadow every three hours.
- High**: Scan the shadow per hour.

```

-----GMPPT-----
PV1 Control
> Low <
  
```

Setting Modbus

You can set the address and select the baud rate of the external communication protocol for communicating with external equipment.



Setting External ATS

External ATS function is used to achieve automatic switching from grid connection mode to off grid mode or from off grid mode to grid connection model by using external ATS equipment. The function is disabled by default. When the X3-PBOX-150K G2 is connected in the parallel system, please enable the function.

- **Enable:** on/off-grid switching by external equipment.
- **Disable:** inverter internal on/off-grid switching.

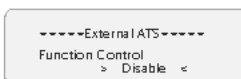

Setting Power Factor

The default value is the specified value under the current safety regulations. The contents will be displayed according to the requirements of local laws and regulations. Please refer to local grid requirements.

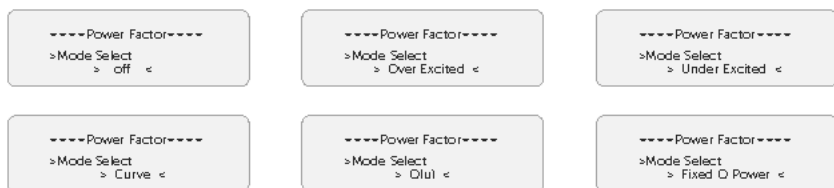

Off

Over Excited PF Value

Under Excited PF Value

Curve	P1 PF
	P2 PF
	P3 PF
	P4 PF
	Power 1
	Power 2
	Power 3
	Power 4
	PflockInPoint
	PflockOutPoint
	3Tua
	Curve
Q(u)	SetQuPower1
	SetQuPower2
	SetQuPower3
	SetQuPower4
	QuRespondV1
	QuRespondV2
	QuRespondV3
	QuRespondV4
	K
	3Tua
	QuDelayTimer
	QuLockEn
	mincosfEn
mincosf	
Fixed Q Power	Q Power
	3Tau

- Reactive power control, reactive power standard curve $\cos \varnothing = f(P)$
 - » For VDE ARN 4105, the curve $\cos \varnothing = f(P)$ should refer to curve A. The set default value is shown in curve A.
 - » For TOR, the curve $\cos \varnothing = f(P)$ should be curve B. The set default value is shown in curve B.
 - » For CEI 0-21, the default value of PFLockInPoint is 1.05. When $V_{ac} > 1.05 V_n, P_{ac} > 0.2 P_n$, curve $\cos \varnothing = f(P)$ corresponds to curve C.

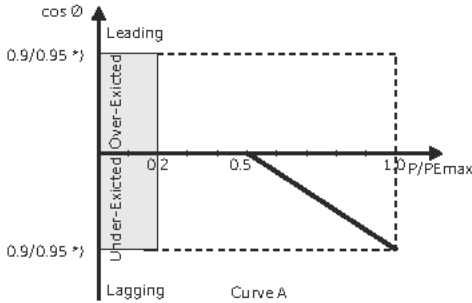

- » *) If the inverter $P_{max} \leq 4.6kW$, the Power Factor is 0.95 at 1.0 power; if the inverter $P_{max} > 4.6kW$, the Power Factor is 0.90 at 1.0 power.

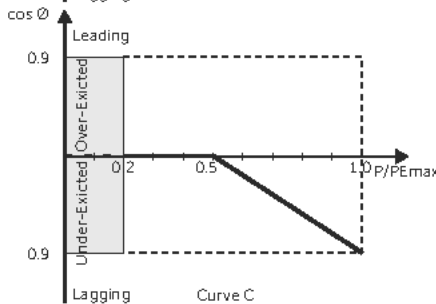
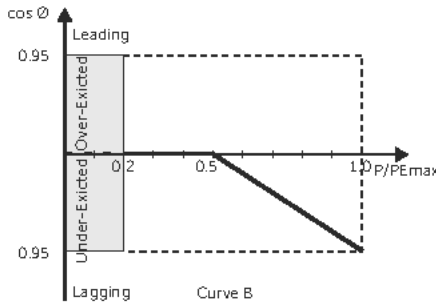

- » *) Depend on the required Q capacity

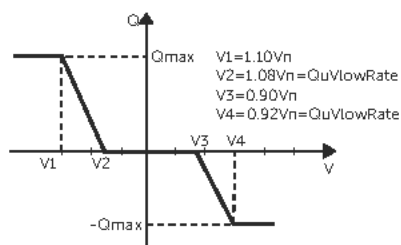

Setting Pu Function

(Applicable to specific countries, please refer to local grid requirements.)

The PU function is a volt-watt response mode required by certain national standards such as AS 4777. This function can control the active power of the inverter according to the grid voltage. You can set **Response Voltage**, **3Tau**, **PuPower**, **3Tau_Charge** and **Pu Type**.



Setting FVRT function

FVRT consists of HVRT (High Voltage Ride Through) and LVRT (Low Voltage Ride Through). With FVRT function, the series inverter can ensure continuous operation without disconnecting from the grid within a certain range of voltage sudden rise and drop in a certain time interval.

- **Enable:** Enable the FVRT function
- **VacUpper:** The voltage for high voltage ride through
- **VacLower:** The voltage for low voltage ride through
- **KFactor:** The ratio of the percentage of reactive current to the percentage of voltage variation
- **Zero Curr Mode:** Default: Disable. When enabled, the voltage drops below 15% and current drops to 0

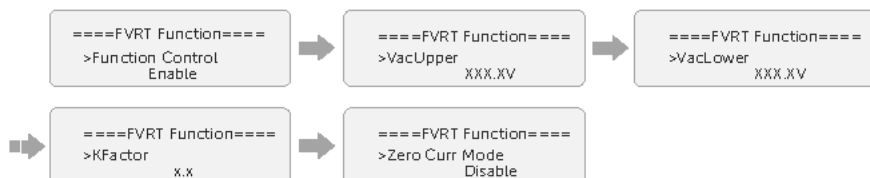

Setting Power Limit

Here you can set the rated output power by percentage.

The percentage of rated output power is used as the actual output power.

Proportion: Default: 1.00; range: 0.00~1.10

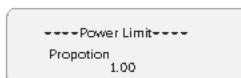

Setting DRM function (Applicable to AS4777)

The DRM Function is a demand response method required by the AS4777 standard and is only applicable to Australia and New Zealand.

The function is enabled by default.

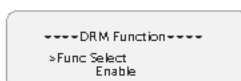

Setting Parallel Connection

In parallel system, there are three status: **Free**, **Slave** and **Master**.

Free	Only if no one inverter is set as a Master , all inverters are in free mode in the system.
Slave	Once one inverter is set as a Master , all other inverters will enter slave mode automatically. Slave mode can not be changed from other modes by LCD setting.
Master	When one inverter is set as a Master , this inverter enters master mode. Master mode can be changed to free mode.

NOTICE!

- Refer to section "8.6.2 Parallel Connection" for specific parallel connection diagram.

NOTICE!

- Master inverter has an absolute lead in the parallel system to control all slave inverter's energy management and dispatch control. Once master inverter has some error and stop working, all slave inverter will be stop simultaneously. But master inverter is independent of all slave inverter to work and will not be affected by slave inverter's fault.
- Overall system will be running according to master inverter's setting parameters, and most setting parameters of slave inverter will be kept but not be cancelled.
- Once slave inverter exits from system and be running as an independent unit (the network cable is disconnected simultaneously), its all setting will be re-activated.

How to build the parallel connection

- Turn on the power of the entire system, find the inverter connected to the meter, enter the setting page of the inverter LCD screen, select the Parallel Setting, and select **Master**; then enter the **Resistance Switch** and set it to **ON**;



- Find the last slave in the parallel system and enter the setting page of the inverter LCD screen and set the **Resistance Switch** to **ON**.

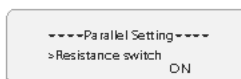

How to remove the parallel connection

- Select the **Parallel Settings** and select **Free** for Master and slave inverter.



- Disconnect all the network cables on the Parallel-1 and Parallel-2 port.

NOTICE!

- If a slave inverter is set to **Free** mode but not disconnect the network cable, this inverter will return to **Slave** mode automatically.
- If a slave inverter is disconnected with master inverter but not be set to **Free** mode, this slave inverter will stop working and prompt **ParallelFault**.

Setting Main Breaker Limit

Due to power limit, the current of Meter or CT must be abide by the utility's requirements. You can set the corresponding amperage according to the utility's requirements. Failure to set the current may cause a circuit breaker fault of main switchboard, thus affecting the charging and discharging of battery.

The default value is 100 A, range: 10-250 A

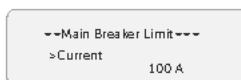

Setting Phase Unbalanced

This function controls the distribution of AC output power. **Disable** is the default setting .

- **Enable** mode: If 60 kW AC power can be exported, each phase power will be divided as below according to different loads connected with each phase.

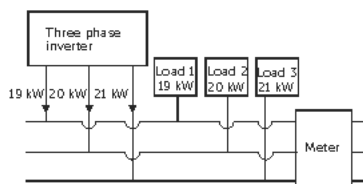

- **Disable** mode: If 60 kW AC power can be exported, each phase power will be divided equally as below and it is unrelated with the loads connected with each phase.

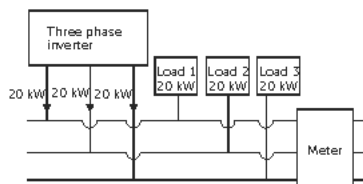

EPS Setting

Select and enter **EPS Setting** interface and set **Frequency**, **Min SOC**, **Min ESC SOC**, **Super-Backup** and **EPSVoltChange**.

- **Frequency**: Default: 50Hz. Output frequency of EPS
- **Min SOC**: Default: 10%, range: 10%-100%
 - » If the battery SOC is lower than the Min SOC set in the inverter, the battery will not discharge the power to the load. The inverter will enter EPS waiting

mode waiting for battery to be charged.

- **Min ESC SoC:** Default: 30%, range: 15%-100%
 - » The minimum SOC to enter EPS mode. When the battery SOC reaches the Min ESC SOC, the inverter will automatically enter EPS mode from EPS Waiting mode.

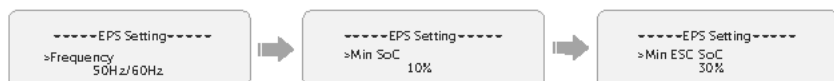

- To enable the "**Super-Backup**" mode and allow only PV without battery to enter EPS. **Disable** is the default setting.

AS4777 Setting

The function of AS4777 Setting is only activated when the Safe Code is set to AS4777 and New Zealand, which is only applicable to Australia and New Zealand.

- Select and enter **AS4777 Setting** in **Advance Setting** interface. You will see **Export Control** (for active power output control) and **General Control** (for apparent power output control).

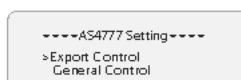

- Set the **Soft Limit** value and **Hard Limit** value for Export Control and General Control. The figure below will take the setup of Export Control as an example.



NOTICE!

- **Soft Limit:** Control the output value to grid within the set **Soft Limit Value**.
- **Hard Limit:** If the actual output value reaches the set **Hard Limit Value**, the system will automatically disconnect from grid and prompt error message on the LCD.

Setting ExternalGen

Two modes are available for you to choose according to actual needs when connecting generator: i.e. ATS Control and Dry Contact.

How to make connection with generator through ATS control

- a. Select and enter **ExternalGen** interface and select **ATS Control**.

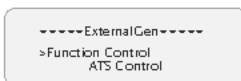

- b. You can set the relative parameters as below in accordance with actual needs.
 - » **MaxChargePower:** Maximum battery charging power from generator. (0-30000 W, 5000W by default)

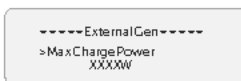

- » **Charge Disc Period:** Including **Forced Charge Period** and **Allowed Disc Period**. Two periods can be set. These period settings are associated with the same settings under **Work Mode** for no need to jump to work mode page to set the working period when using generator mode.

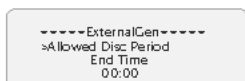
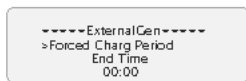
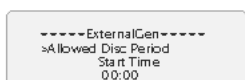
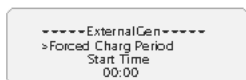

- » **Charge from Gen and Charge battery to:** The SOC which allows the system charging from generator. (10-100%, 10% by default)

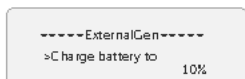
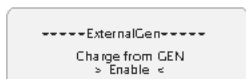

How to make connection with generator through Dry Contact

- a. Select and enter **ExternalGen** interface and select **Dry Contact**.



- b. Set the relative parameters in accordance with actual needs.
 - » **MaxChargePower:** Maximum battery charging power from generator. (0-30000 W, 5000W by default).

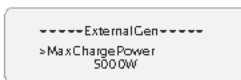

- » **Start Gen Method:** **Reference SOC** and **Immediately** can be selected.
Reference SOC: Turn on/off generator according to the set SOC.
Immediately: Turn on /off the generator when grid status changed.

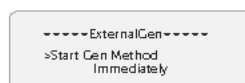
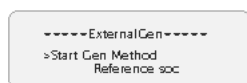

- » **Switch on/off SOC:** the option is activated when you select **Reference SOC** for **Start Gen Method**. Inverter will turn on the generator when the battery reaches the set **Switch on SOC** and turn it off when the battery reaches the set **Switch off SOC**.

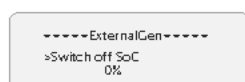
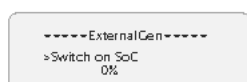

- » **MaxRunTime:** Maximum operating time of generator. (30 Min by default)

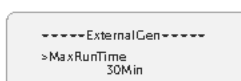

- » **MinRestTime:** Minimum time interval for two consecutive starts to avoid frequent generator switching ON/OFF.

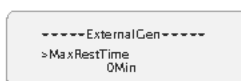

- » **Char&Disc Period:** Including **Forced Charge Period** and **Allowed Disc Period**. Two periods can be set. These period settings are associated with the same settings under **Work Mode** for no need to jump to work mode page to set the working period when using generator mode.

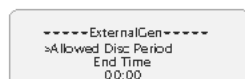
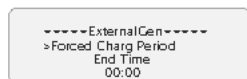
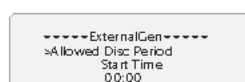
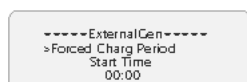

- » **Allow Work:** Allowed time period for generator operating. You can set the start time and end time.

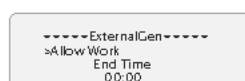
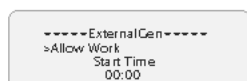

- » **Charge from Gen and Charge battery to:** The SOC which allows the system charging from generator. (10-100 W from generator, 10% by default)



Reset

Here you can reset value of Error Log, Meter/CT, INV Energy and Wifi; and restore to the factory set.

- **Reset Error Log**



- **Reset Meter/CT**



- **Reset INV Energy**



- **Reset Wifi**



- **Factory Reset**



Setting Battery Heating

This function is disabled by default and is only valid when the battery has the heating function. You can enable **Battery Heating** function to make the battery heated. And set the heating period.

- Enable the **Battery Heating** function.

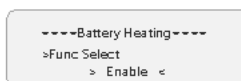

- b. Set the heating start time and end time for the battery. Two heating periods can be set.

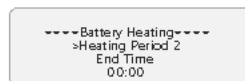
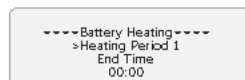

Setting Extend BAT FUNC

This function allows for the extension of battery modules, such as adding a new battery module to an existing system. It is only applicable and functional in on-grid mode and cannot be used in EPS mode. In on-grid mode, enabling this function will make the inverter to charge or discharge the battery SOC to approximately 38%. This function will turn to **Disable** automatically after 48 hours this function enabled..

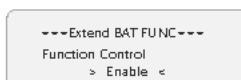

Setting HotStandby Setting

This function is mainly to reduce the energy losses of the system. when the power of load is extremely low and there is no sufficient PV input voltage, or when the battery SOC is less than or equal to 10% and there is no sufficient PV input voltage, the inverter will enter "HotStandby" status. When the power of loads is higher than 150 W, or there is sufficient PV input voltage, or the battery is forced charged, the inverter will exit "HotStandby" status.

It is disabled by default.

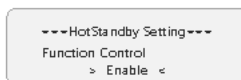

Setting Pgrid Bias

This function is disabled by default.

For the country with zero export limit:

- Check the **Meter/CT** value in **Menu>System Status>Meter/CT** when the function is disabled.

- b. If the **Meter/CT** displayed in **System Status** is negative value, please select **Grid** for **Pgrid Bias** to discharge power to the mains. If the **Meter/CT** displayed in **System Status** is positive value, please select **INV** for **Pgrid Bias** to take power from the mains.



Setting Internal485

You can communicate with other SolaX equipment, such as EV Charger, Datahub, Adapter Box G2 and EMS through **Internal485**.

- a. Select and enter **Internal485** interface;
- b. Select the equipment which needs to be connected and set the corresponding Baud Rate and Address. Take EV Charger as an example.

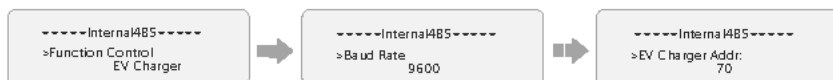

NOTICE!

- When two equipments need to be connected at the same time, the baud rate and address of the two equipments shall be set to the same.

- c. Check the connecting status. For the connection status of Datahub, please check it on the Datahub.



NOTICE!

- Please refer to "8.6.4 RS485 Communication Connection" for specific wiring connection of Datahub, EV Charger and Adapter Box.

Battery Charge EVC

You can set **Enable** to allow the battery to discharge energy to EV Charger. When you set to **Disable**, battery discharging energy to EV Charger is not allowed.

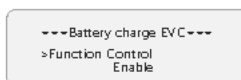

Setting MicroGrid

Here you can enable MicroGrid function if an on-grid inverter is connected.

- **Function Control:** Control microgrid functions, default: Disable



- **PV INV Max Power:** Maximum power of the on-grid inverter when it's off-grid



Arc Setting

The inverter has arc detection function, which detects the arcing of the DC side and cuts the circuit in time to protect the user and the electrical system. The arc module of the series inverter meets the requirements of IEC 63027.

The user can do settings about **ARC Enable** and **ARC Self Check**.

- **ARC Enable:** Select **Enable** in **ARC Enable**, the inverter will report **ARC Test Fault** when faults are detected. When it is disabled, there won't be any reports even when faults occurred, and the faults will be cleared simultaneously

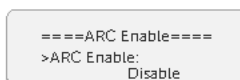

- **ARC Self Check:** Select **Trigger** in **ARC Self Check**, the inverter will self-check whether the arc detection function is working normally and return to **NULL** after the checking process is completed.

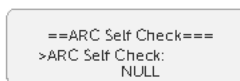

NOTICE!

- **ARC Self Check** should be done when the inverter is in normal state and the current is greater than 1.5 A. If an **ARC Test Success** is reported, the arc detection function is working normally.

Advance Password

You can reset the advanced password here.

9.10 Inverter screen cover installation

Step 1: Put the inverter screen cover on the inverter and secure the cover on the two sides of the inverter with M4*10 screws (Torque: 1.6 ± 0.1 N·m).

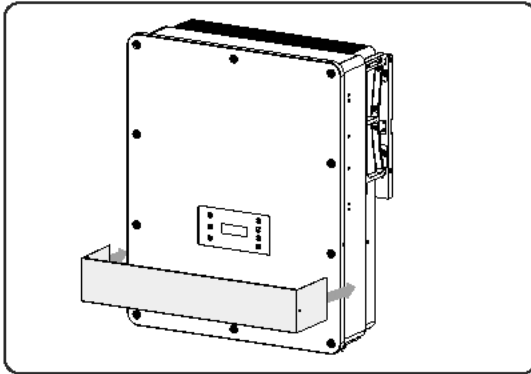

Figure 9-2 Putting the screen cover on the inverter

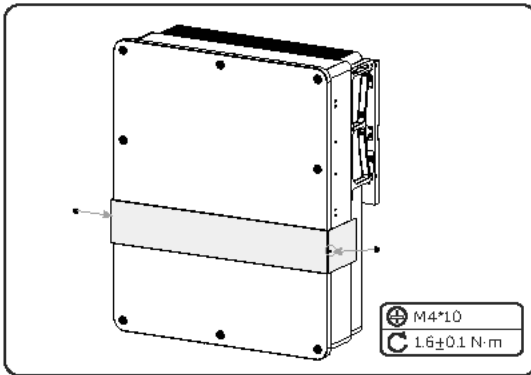

Figure 9-3 Securing the cover with the inverter

9.9 About

Displaying path: **Menu > About**

Here shows the basic information of the inverter, battery, ARC clear and internal code. After entering the **About** interface, you can check those information.

- Inverter
 - » Inverter SN, Register SN, ARM Verion, DSP version, On-grid Runtime, EPS Runtime
- Battery1 and Battery2
 - » BatBrand, Bat_M SN (SN of BMS), Bat_PS1 SN (SN of battery module 1), Bat_PS2 SN (SN of battery module 2), Bat_PS3 SN (SN of battery module 3), Bat_PS4 SN (SN of battery module 4), Battery M Version (software version of BMS) and Battery S version (software version of battery module).
- ARC Clear
 - » When it is **Null** by default, the inverter will automatically clear the arc fault in five minutes for up to four consecutive times. If the arc fault happened the fifth time, manual clear is needed. For manual clear, select **Trigger** in **Arc Clear**, the inverter will clear the arc fault immediately and restart the system.

```

=====ARC Clear=====
ARC Clear:
> Null <
  
```

- Internal Code
 - » Internal code of inverter, battery1, battery2 and ARC info.

10 SolaXCloud App

10.1 Introduction of SolaXCloud

SolaxCloud is an intelligent management platform for home energy, which integrates energy efficiency monitoring, device management, data security communication and other integrated capabilities. While managing your home energy device, it helps you optimize the efficiency of electricity consumption and improve the revenue of power generation.

10.2 Operation Guide on SolaXCloud App

10.2.1 Downloading and Installing App

Method 1: Scan the QR code below to download the App.

The QR codes are also available on the login page of our official website (www.solaxcloud.com).



Figure 10-1 QR code

Method 2: Search for **SolaXCloud** in Apple Store App or Google Play, and then download the App.

10.2.2 Operation on the SolaXCloud App

For instructions on the related operations, see the online documents on the SolaXCloud App.

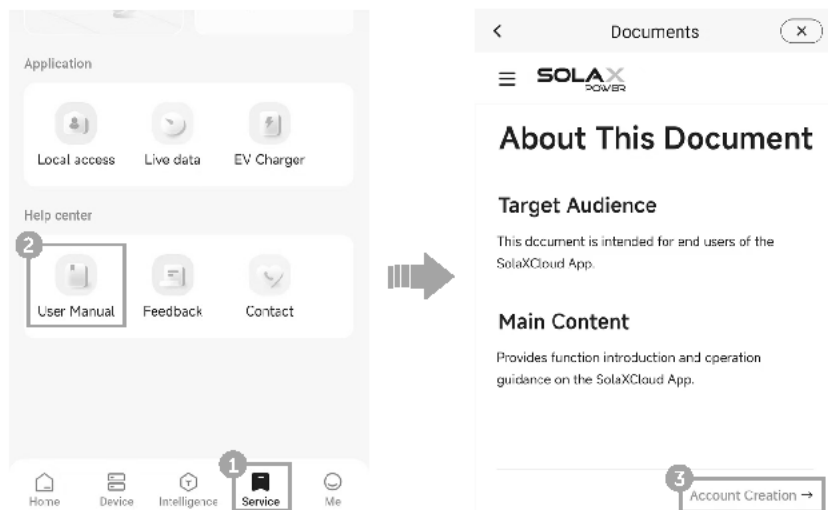

Figure 10-2 Online help on SolaXCloud

NOTICE!

- The screen shots in this chapter correspond to the SolaXCloud App V6.5.1, which might change with version update and should be subject to the actual situations.

11 Troubleshooting and Maintenance

11.1 Power off

Step 1: Inverter power off.

- a. Set **OFF** in the **System ON/OFF** on the inverter LCD screen.
- b. Turn off the inverter system button.
- c. Set the DC switch1 and DC switch2 to "OFF".

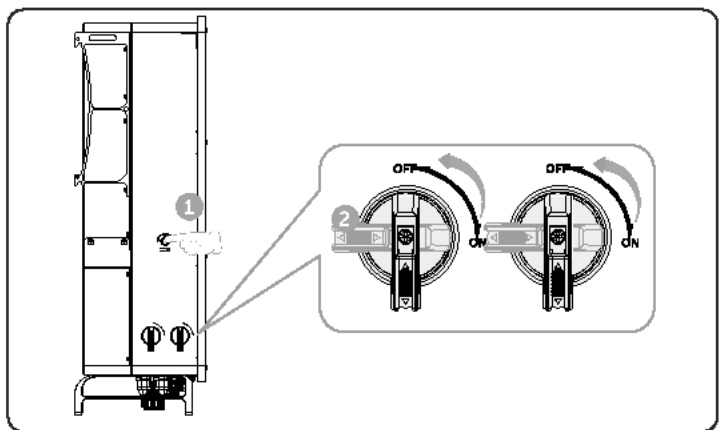

Figure 11-1 Shutting down the inverter

Step 2: Gently flip down breaker.

Step 3: Rotate the disconnecter of the high-voltage box to "OFF". At the point, the LED light will disappear.

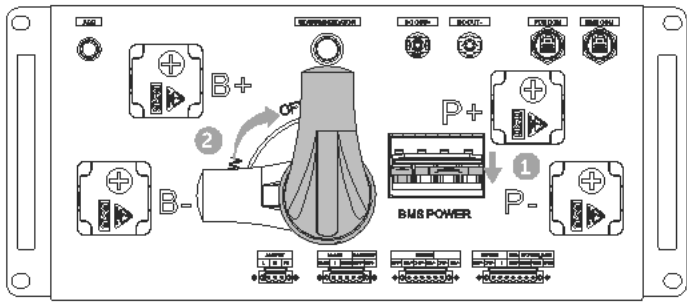

Figure 11-2 Turn off breaker and disconnecter

Step 4: Turn off the AC breakers between the inverter and the power grid.



- After the system powers off, there will still be the remaining electricity and heat which may cause electric shocks and body burns. Please wear personal protective equipment (PPE) and begin servicing 15 minutes after power off.

11.2 Troubleshooting

This section contains information and procedures for resolving possible problems with the device and provides the troubleshooting tips to identify and solve most problems that may occur. Please conform the state of the indicators to check the status of the device, check the warning or fault information via the monitoring software on the inverter, and read the suggested solutions below when error occurs.

In case of the following circumstances, e.g. voltage or temperature exceeds the limit specified, a warning state will be triggered.

The BMS will periodically report battery operating state to the inverter. Therefore, when a warning is reported, the inverter will stop working immediately.

Contact SolaX Customer Service for further assistance. Please be prepared to describe the details of your system installation and provide the model and serial number of the device.

Table 11-1 Battery troubleshooting information

Error Code	Fault	Diagnosis and Solution
UCellOverFault	Overvoltage fault of single cell	High voltage of single cell. <ul style="list-style-type: none"> • Wait for the voltage of single cell to decrease. • Contact the after-sales personnel of our company.
UCellLowFault	Undervoltage fault of single cell	Low voltage of single cell. <ul style="list-style-type: none"> • Charge the battery.
UCellDiffFault	Voltage difference fault of battery cell	Voltage difference fault of battery cell. <ul style="list-style-type: none"> • Contact the after-sales personnel of our company.
HVBOverFault	Overvoltage fault of total voltage	High total voltage of battery. <ul style="list-style-type: none"> • Wait for the total voltage to decrease.
HVBLowFault	Undervoltage fault of total voltage	Low total voltage of battery. <ul style="list-style-type: none"> • Charge the battery.

Error Code	Fault	Diagnosis and Solution
TempOverFault	High-temperature fault	High-temperature of battery. <ul style="list-style-type: none"> • Wait for the temperature of battery to decrease.
SelfCheckFault	Self-check fault of battery	Self-check failure of battery. <ul style="list-style-type: none"> • Contact the after-sales personnel of our company.
PosRlyAdhFault	Main positive relay adhesion fault	Main positive relay adhesion fault. <ul style="list-style-type: none"> • Contact the after-sales personnel of our company.
PosRlyOpenFault	Main positive relay open circuit fault	Main positive relay open circuit fault. <ul style="list-style-type: none"> • Contact the after-sales personnel of our company.
NegRlyAdhFault	Main negative relay adhesion fault	Main negative relay adhesion fault. <ul style="list-style-type: none"> • Contact the after-sales personnel of our company.
NegRlyOpenFault	Main negative relay open circuit fault	Main negative relay open circuit fault. <ul style="list-style-type: none"> • Contact the after-sales personnel of our company.
PreChgFailFault	Precharging fault	Precharging failure. <ul style="list-style-type: none"> • Check if the disconnecter is closed. • Contact the after-sales personnel of our company.
CellSampleFault	Voltage sampling fault of single cell	Voltage sampling fault of single cell. <ul style="list-style-type: none"> • Contact the after-sales personnel of our company.
TempSampleFault	Temperature sampling fault of single cell	Temperature sampling fault of single cell. <ul style="list-style-type: none"> • Contact the after-sales personnel of our company.
SysFault	System fault	System fault. <ul style="list-style-type: none"> • Contact the after-sales personnel of our company.
DsgOverFault	Discharge overcurrent fault	Discharge overcurrent. <ul style="list-style-type: none"> • Contact the after-sales personnel of our company.
ChgOverFault	Charge overcurrent.	Charge overcurrent. <ul style="list-style-type: none"> • Contact the after-sales personnel of our company.

Error Code	Fault	Diagnosis and Solution
IComFault	Internal communication fault	Internal communication fault. <ul style="list-style-type: none"> • Contact the after-sales personnel of our company.
InvComFault	External communication fault	External communication fault. <ul style="list-style-type: none"> • Contact the after-sales personnel of our company.
MidComFault	Intermediate network communication fault	Intermediate network communication fault. <ul style="list-style-type: none"> • Contact the after-sales personnel of our company.
VoltSensorFault	Voltage sensor fault	Voltage sensor fault. <ul style="list-style-type: none"> • Check if the communication of slave BMS is normal and if power cables are properly connected. • If the issue cannot be resolved, contact the after-sales personnel of our company.
IDRepetFault	ID repeat fault	ID repeat. <ul style="list-style-type: none"> • Contact the after-sales personnel of our company.
TempLowFault	Low-temperature fault	Low-temperature of the battery. <ul style="list-style-type: none"> • Ensure that the operating environment meets the requirements of the manual. • Check if the air conditioner and fan are working properly, and if the air conditioner is turned on for heating.
CurrSensorFlt	Current sensor fault	Relay disconnected and absolute current > 5A. <ul style="list-style-type: none"> • Contact the after-sales personnel of our company.
LineFlt	Power cable fault	Power cable fault. <ul style="list-style-type: none"> • Check if power cables are properly connected.
FlashFlt	Flash fault	Unable to detect external flash communication. <ul style="list-style-type: none"> • Contact the after-sales personnel of our company.

Error Code	Fault	Diagnosis and Solution
AFEProtectFlt	AFE protection fault	AFE protection fault. <ul style="list-style-type: none"> • Contact the after-sales personnel of our company.
ChgReqFlt	Charge request fault	Fail to charge after initiating a charging request. <ul style="list-style-type: none"> • Contact the after-sales personnel of our company.
InsFlt	Insulation fault	Abnormal external insulation. <ul style="list-style-type: none"> • Contact the after-sales personnel of our company.
MCBFlt	MCB fault	MCB fault. <ul style="list-style-type: none"> • Contact the after-sales personnel of our company.
LinkerTempHi	High temperature fault of high-voltage connector	High temperature of high-voltage connector. <ul style="list-style-type: none"> • Ensure that the operating environment meets the requirements of the manual. • Check if the air conditioner and fan are working properly, and if the air conditioner is turned on for cooling.
BatLinkerError	High temperature fault of pole	High temperature of pole. <ul style="list-style-type: none"> • Contact the after-sales personnel of our company.
FanError	Fan fault	Fan fault. <ul style="list-style-type: none"> • Contact the after-sales personnel of our company.
FireFault	Fire fault	Fire fault. <ul style="list-style-type: none"> • Contact the after-sales personnel of our company.
MSDFault	Disconnection fault of MSD	Disconnection of MSD. <ul style="list-style-type: none"> • Contact the after-sales personnel of our company.

Table 11-2 Inverter troubleshooting information

Error Code	Fault	Descriptions and Diagnosis
IE 01	TZ Protect Fault	<p>Overcurrent fault.</p> <ul style="list-style-type: none"> • Wait for a while to check if it returns to normal. • Disconnect PV+ PV- and batteries, reconnect. • If the system is in off-grid state, check if the power of EPS loads exceeds the maximum limit of the system or exceeds the current power supply of battery. • If the system fails to restore to its normal state, please contact SolaX for help.
IE 02	Grid Lost Fault	<p>Grid Lost Fault</p> <ul style="list-style-type: none"> • Check the grid connection status • Or contact SolaX for help.
IE 03	Grid Volt Fault	<p>Power grid voltage overrun</p> <ul style="list-style-type: none"> • Wait a moment, if the utility returns to normal, the system will reconnect. • Please check if the grid voltage is within normal range. • Or contact SolaX for help.
IE 04	Grid Freq Fault	<p>Grid overfrequency</p> <ul style="list-style-type: none"> • Wait a moment. If the utility returns to normal, the system reconnects. • Or contact SolaX for help.
IE 05	PV Volt Fault	<p>PV overvoltage</p> <ul style="list-style-type: none"> • Check the output voltage of the PV panel. • Check if the DC switch is OFF. • Or contact SolaX for help.
IE 06	Bus Volt Fault	<ul style="list-style-type: none"> • Press the ESC key to restart the inverter. • Check if the PV input open circuit voltage is in the normal range. • Check if the power of half-wave load exceeds the system limit. • Or contact SolaX for help.
IE 07	Bat Volt Fault	<p>Battery voltage fault</p> <ul style="list-style-type: none"> • Check if the battery input voltage is within normal range • Or contact SolaX for help.
IE 08	AC10mins Volt	<p>Grid voltage out of range in the last 10 minutes.</p> <ul style="list-style-type: none"> • The system will return to normal if the grid returns to normal. • Or contact SolaX for help.

Error Code	Fault	Descriptions and Diagnosis
IE 09	DCI OCP Fault	DCI overcurrent protection fault. <ul style="list-style-type: none"> • Wait for a while to check if it's back to normal. • Or contact SolaX for help.
IE 10	DCV OVP Fault	DCV EPS(Off-grid) overvoltage protection fault. <ul style="list-style-type: none"> • Wait for a while to check if it's back to normal. • Or contact SolaX for help.
IE 11	SW OCP Fault	Software detection of overcurrent Fault. <ul style="list-style-type: none"> • Wait for a while to check if it's back to normal. • Shut down photovoltaic, battery and grid connections. • Or contact SolaX for help.
IE 12	RC OCP Fault	Overcurrent protection fault. <ul style="list-style-type: none"> • Check the impedance of DC input and AC output. • Wait for a while to check if it's back to normal. • Or contact SolaX for help.
IE 13	Isolation Fault	Insulation fault <ul style="list-style-type: none"> • Please check the wire insulation for damage. • Wait for a while to check if it's back to normal. • Or contact SolaX for help.
IE 14	Temp Over Fault	Temperature out of range <ul style="list-style-type: none"> • Check if the ambient temperature exceeds the limit. • Or contact SolaX for help.
IE 15	Bat Con Dir Fault	<ul style="list-style-type: none"> • Battery direction fault • Check if the battery lines are connected in the opposite direction. • Or ask for help from the installer if it can not return to normal.
IE 16	EPS Overload	EPS(Off-grid) overload fault <ul style="list-style-type: none"> • Shutdown the high-power device and press the ESC key to restart the inverter. • Or contact SolaX for help if it can not return to normal.
IE 17	Overload Fault	On-grid mode overload fault <ul style="list-style-type: none"> • Shutdown the high-power device and press the ESC key to restart the inverter. • Or contact SolaX for help if it can not return to normal.

Error Code	Fault	Descriptions and Diagnosis
IE 18	BatPowerLow	<p>Bat Power Low</p> <ul style="list-style-type: none"> • Shutdown the high-power device and press the ESC key to restart the inverter. • Please charge the battery to a level higher than the protection capacity or protection voltage.
IE 19	BMS Lost	<p>Battery communication lost</p> <ul style="list-style-type: none"> • Check that the communication cable between the battery and the inverter are properly connected. • Or contact SolaX for help if it can not return to normal.
IE 20	Fan Fault	<p>Fan Fault</p> <ul style="list-style-type: none"> • Check for any foreign matter that may have caused the fan not to function properly. • Or contact SolaX for help if it can not return to normal.
IE 21	Low TempFault	<p>Low temperature fault.</p> <ul style="list-style-type: none"> • Check if the ambient temperature is too low. • Or contact SolaX for help if it can not return to normal.
IE 25	InterComFault	<p>Inter_Com_Fault</p> <ul style="list-style-type: none"> • Restart the inverter. • Or contact SolaX for help if it can not return to normal.
IE 26	INV EEPROM	<p>Inverter EEPROM Fault.</p> <ul style="list-style-type: none"> • Shut down photovoltaic, battery and grid, reconnect. • Or contact SolaX for help if it can not return to normal.
IE 27	RCD Fault	<p>Residual Current Device fault</p> <ul style="list-style-type: none"> • Check the impedance of DC input and AC output. • Disconnect PV+ ,PV- and batteries, reconnect. • Or contact SolaX for help if it can not return to normal.
IE 28	Grid Relay Fault	<p>Electrical relay fault</p> <ul style="list-style-type: none"> • Disconnect PV+ ,PV- , grid and batteries and reconnect. • Or contact SolaX for help if it can not return to normal.
IE 29	EPS Relay	<p>EPS(Off-grid) relay fault</p> <ul style="list-style-type: none"> • Disconnect PV+ ,PV- , grid and batteries and reconnect. • Or contact SolaX for help if it can not return to normal.

Error Code	Fault	Descriptions and Diagnosis
IE 30	PV ConnDirFault	<p>PV direction fault</p> <ul style="list-style-type: none"> Check if the PV input lines are connected in the opposite direction. Or contact SolaX for help if it can not return to normal.
IE 31	Battery Relay	<p>Charge relay fault</p> <ul style="list-style-type: none"> Press the ESC key to restart the inverter. Or contact SolaX for help if it can not return to normal.
IE 32	Earth Relay	<p>EPS(Off-grid) earth relay fault</p> <ul style="list-style-type: none"> Press the ESC key to restart the inverter. Or contact SolaX for help if it can not return to normal.
IE 100	PowerTypeFault	<p>Power type fault</p> <ul style="list-style-type: none"> Upgrade the software and press the ESC key to restart the inverter. Or contact SolaX for help if it can not return to normal.
IE 102	Mgr EEPROM Fault	<p>Mgr E2prom Error.</p> <ul style="list-style-type: none"> Shut down photovoltaic ,battery and grid, and then reconnect. Or contact SolaX for help if it can not return to normal.
IE 103	Fan4 Fault	<p>FAN4 Fault</p> <ul style="list-style-type: none"> Check if the foreign objects stuck in the fan. Or contact SolaX for help.
IE 104	NTC Sample Invalid	<p>NTC Sample Fault</p> <ul style="list-style-type: none"> Make sure the NTC is properly connected and the NTC is in good condition. Please confirm that the installation environment is normal Or contact SolaX for help if it can not return to normal.
IE 107	CT Fault	<p>CT Fault</p> <ul style="list-style-type: none"> Check if the CT is working properly Or contact SolaX for help if it can not return to normal.
IE 109	Meter Fault	<p>Meter Fault</p> <ul style="list-style-type: none"> Check if the meter is working properly Or contact SolaX for help if it can not return to normal.

Error Code	Fault	Descriptions and Diagnosis
IE 110	BypassRelayFlt	<p>Bypass Relay Fault</p> <ul style="list-style-type: none"> Press the ESC key to restart the inverter. Or contact SolaX for help if it can not return to normal.
IE 111	FAN3 Fault	<p>FAN3 Fault</p> <ul style="list-style-type: none"> Check if the foreign objects stuck in the fan. Or contact SolaX for help.
IE 112	ARMParaComFlt	<p>ARM Parameter Communication fault</p> <ul style="list-style-type: none"> Check that the communication cables of inverters are well connected and the baud rate of COMM setting of inverters are the same. Or contact SolaX for help if it can not return to normal.
IE 113	FAN1 Fault	<p>FAN1 Fault</p> <ul style="list-style-type: none"> Check if the foreign objects stuck in the fan. Or contact SolaX for help.
IE 114	FAN2 Fault	<p>FAN2 Fault</p> <ul style="list-style-type: none"> Check if the foreign objects stuck in the fan. Or contact SolaX for help.
IE 115	20305Com Fault	<p>Com Fault</p> <ul style="list-style-type: none"> Check the connection of the monitoring module, reinsert the module. Please contact SolaX for help.
BE 01	BMS1_UCellOver BMS2_UCellOver	<p>Battery Error - Cell Overvoltage Fault</p> <ul style="list-style-type: none"> Please contact SolaX for help.
BE 02	BMS1_UCellLow BMS2_UCellLow	<p>Battery Error - Cell Undervoltage Fault</p> <ul style="list-style-type: none"> Please contact SolaX for help.
BE 03	BMS1_UCellDiff BMS2_UCellDiff	<p>Battery Error - Large Cell Differential Pressure Fault</p> <ul style="list-style-type: none"> Please contact SolaX for help.
BE 04	BMS1_HVBOver BMS2_HVBOver	<p>Battery Error - Total Voltage Overvoltage Fault</p> <ul style="list-style-type: none"> Please contact SolaX for help.
BE 05	BMS1_HVBLow BMS2_HVBLow	<p>Battery Error - Total Voltage Undervoltage Fault</p> <ul style="list-style-type: none"> Please contact SolaX for help.
BE 06	BMS1_TempOver BMS2_TempOver	<p>Over temperature in battery system</p> <ul style="list-style-type: none"> Please contact SolaX for help.

Error Code	Fault	Descriptions and Diagnosis
BE 07	BMS1_SelfCheck	Self check fault in battery system <ul style="list-style-type: none"> • Please contact SolaX for help.
	BMS2_SelfCheck	
BE 08	BMS1_PoRlyAdh	Battery Error - Main Positive Relay Adhesion Fault <ul style="list-style-type: none"> • Please contact SolaX for help.
	BMS2_PoRlyAdh	
BE 09	BMS1_PoRlyOpen	Battery Error - Main Positive Open Relay Fault <ul style="list-style-type: none"> • Please contact SolaX for help.
	BMS2_PoRlyOpen	
BE 10	BMS1_NeRlyAdh	Battery Error - Main Negative Relay Adhesion Fault <ul style="list-style-type: none"> • Please contact SolaX for help.
	BMS2_NeRlyAdh	
BE 11	BMS1_NeRlyOpen	Battery Error - Main Negative Open Relay Fault <ul style="list-style-type: none"> • Please contact SolaX for help.
	BMS2_NeRlyOpen	
BE 12	BMS1_PreChgFail	Battery Error - Battery Precharge Fault <ul style="list-style-type: none"> • Please contact SolaX for help.
	BMS2_PreChgFail	
BE 13	BMS1_CellSample	Battery Error - Battery Cell Sampling Fault <ul style="list-style-type: none"> • Please contact SolaX for help.
	BMS2_CellSample	
BE 14	BMS1_TempSample	Battery Error - Battery Temperature Sampling Fault <ul style="list-style-type: none"> • Please contact SolaX for help.
	BMS2_TempSample	
BE 15	BMS1_Sys	Battery Error - Battery System Fault <ul style="list-style-type: none"> • Please contact SolaX for help.
	BMS2_Sys	
BE 16	BMS1_DsgOver	Battery Error - Battery Discharge Overcurrent Fault <ul style="list-style-type: none"> • Please contact SolaX for help.
	BMS2_DsgOver	
BE 17	BMS1_ChgOver	Battery Error - Battery Charge Overcurrent Fault <ul style="list-style-type: none"> • Please contact SolaX for help.
	BMS2_ChgOver	
BE 18	BMS1_AFECOM	Battery Error - Battery AFE communication Fault <ul style="list-style-type: none"> • Please contact SolaX for help.
	BMS2_AFECOM	
BE 19	BMS1_InvCom	Battery Error - Extranet Communication Fault <ul style="list-style-type: none"> • Please contact SolaX for help.
	BMS2_InvCom	
BE 20	BMS1_MidCom	Battery Error - Intermediate Network Communication Fault <ul style="list-style-type: none"> • Please contact SolaX for help.
	BMS2_MidCom	

Error Code	Fault	Descriptions and Diagnosis
BE 21	BMS1_VoltSensor	Battery Error - Voltage Sensor Fault <ul style="list-style-type: none"> • Please contact SolaX for help.
	BMS2_VoltSensor	
BE 22	BMS1_IDRepet	Battery Error - Repetitive ID Fault <ul style="list-style-type: none"> • Please contact SolaX for help.
	BMS2_IDRepet	
BE 23	BMS1_TempLow	Battery Error - Low Temperature Fault <ul style="list-style-type: none"> • Please contact SolaX for help.
	BMS2_TempLow	
BE 24	BMS1_CurrSensor	Battery Error - Current Sensor Fault <ul style="list-style-type: none"> • Please contact SolaX for help.
	BMS2_CurrSensor	
BE 25	BMS1_Line	Battery Error - Open Power Cable Fault <ul style="list-style-type: none"> • Please contact SolaX for help.
	BMS2_Line	
BE 26	BMS1_Flash	Battery Error - Flash Fault <ul style="list-style-type: none"> • Please contact SolaX for help.
	BMS2_Flash	
BE 27	BMS1_AFEProtect	Battery Error - AFE Self-protection Fault <ul style="list-style-type: none"> • Please contact SolaX for help.
	BMS2_AFEProtect	
BE 28	BMS1_ChgReq	Battery Error - Charge Request Fault <ul style="list-style-type: none"> • Please contact SolaX for help.
	BMS2_ChgReq	
BE 29	BMS1_Ins	Battery Error - Battery Insulation Fault <ul style="list-style-type: none"> • Check that the battery is properly grounded and restart the battery. • Please contact SolaX for help.
	BMS2_Ins	
BE 30	BMS1_MCB	Battery Error - Micro Circuit Breaker Fault <ul style="list-style-type: none"> • Please contact SolaX for help.
	BMS2_MCB	
BE 31	BMS1_LinkTemp	Battery Error - Contactor Over Temperature Fault <ul style="list-style-type: none"> • Please contact SolaX for help.
	BMS2_LinkTemp	
BE 32	BMS1_BatLinker	Battery Error - Internal contact point Abnormally high in the battery <ul style="list-style-type: none"> • Please contact SolaX for help.
	BMS2_BatLinker	
BE 33	BMS1_Fan	Battery Error - Fan Fault <ul style="list-style-type: none"> • Check if the foreign objects stuck in the fan. • Or contact SolaX for help.
	BMS2_Fan	

11.3 Maintenance

Regular maintenance is required for the AELIO+HR140 system. The table below lists the operational maintenance for expressing the optimum device performance. More frequent maintenance service is needed in the worse work environment. Please make records of the maintenance.



- Only qualified person can perform the maintenance for the device.
- Only use the spare parts and accessories approved by SolaX for maintenance.

11.3.1 Maintenance Routines

Table 11-3 Maintenance routines

Item	Check notes	Maintenance interval
Fans	<ul style="list-style-type: none"> • Check if the cooling fans of the inverter and the battery packs are covered by dirt or if there is abnormal sound. • Clean the cooling fans with a soft dry cloth or brush or replace it if necessary. 	Every 6-12 months
Electrical connection	<ul style="list-style-type: none"> • Ensure that all cables are firmly connected. • Check the integrity of the cables, ensuring that there are no scratches on the parts touching the metallic surface. • Verify that the sealing caps on idle terminals are and not falling off. 	Every 6-12 months
Grounding reliability	<ul style="list-style-type: none"> • Check whether the ground terminal and ground cable are securely connected. • Use Ground Resistance Tester to test the ground resistance from inverter enclosure to PE bar in the power distribution box. 	Every 6-12 months
Heat sink	<ul style="list-style-type: none"> • Check whether the heat sink is covered with foreign objects. 	Every 6-12 months
General status of system	<ul style="list-style-type: none"> • Check if there is any damage on the device. • Check if there is any abnormal sound when the device is running. 	Every 6 months

12 Decommissioning

12.1 Disposing of the Wasted and Damaged Battery Pack

Regarding the wasted or damaged battery packs, SolaX will not recycle them. Therefore, users can contact a recycling agency to dispose of them. The expenses incurred shall be borne by the users themselves.

Step 1: Contact a recycling agency, and estimate the expenses.

Step 2: The recycling agency will take full responsibility for dispose of the wasted or damaged battery packs.

12.2 Disposing of the Wasted and Damaged Inverter

Please dispose of the inverters or accessories in accordance with the disposal regulations for electronic waste which is applied at the installation site.

13 Technical Data

Inverter performance parameter

- DC input

Model	X3-AELIO-50K	X3-AELIO-60K	X3-AELIO-49.9K	X3-AELIO-61K	X3-AELIO-49.9K-P
Max. recommended PV array power [Wp]	100000	120000	100000	120000	120000
Max. PV input power [kW]	100000 (A:30000 / B:30000 / C:30000 / D:30000 / E:30000)	120000 (A:30000 / B:30000 / C:30000 / D:30000 / E:30000 / F:30000)	100000 (A:30000 / B:30000 / C:30000 / D:30000 / E:30000)	120000 (A:30000 / B:30000 / C:30000 / D:30000 / E:30000 / F:30000)	120000 (A:30000 / B:30000 / C:30000 / D:30000 / E:30000 / F:30000)
Max. PV input voltage [V] ^①	1000				
Nominal PV input voltage [V]	650				
Max. input current per MPPT [A]	40				
Max. input short circuit current per MPPT [A] ^②	50				
Max. inverter backfeed current to the array [A]	0				
MPPT voltage range [V]	160-950				
Start-up voltage [V]	180				
Shutdown input voltage [V]	150				
No. of MPP trackers	5	6	5	6	6
Strings per MPP tracker	2				
DC disconnection switch	YES				

Note:

- ① The maximum input voltage represents the highest DC voltage threshold for the inverter, approaching which power derating occurs and any further increase might lead to potential damage to the inverter.
- ② Max. current for each PV input string is 50A.
- ③ PV voltage out of the full load MPPT range will trigger the inverter derating protection or possibly cause damage to the inverter if it exceeds the Max. input voltage.

- AC output

Model	X3-AELIO-50K	X3-AELIO-60K	X3-AELIO-49.9K	X3-AELIO-61K	X3-AELIO-49.9K-P
Rated AC power [W]	50000	60000	49900	61000	49900
Max. apparent AC power [VA] (below +45°C)	55000	66000	49999	66000	49999
Rated grid voltage (AC voltage range) [V]	3 / N / PE, 220 / 380V 3 / N / PE, 230 / 400V 3 / N / PE, 240 / 415V				
Rated grid frequency [Hz]	50 / 60				
Nominal AC current [A]	75.8 @ 220V 72.5 @ 230V 69.5 @ 240V	91.0 @ 220V 87.0 @ 230V 83.4 @ 240V	75.7 @ 220V 72.4 @ 230V 69.4 @ 240V	92.5 @ 220V 88.5 @ 230V 84.8 @ 240V	75.7 @ 220V 72.4 @ 230V 69.4 @ 240V
Max. AC current [A] (above rated current, de-rating is acceptable)	83.4 @ 220V 79.8 @ 230V 76.4 @ 240V	100.0 @ 220V 95.7 @ 230V 91.7 @ 240V	75.7 @ 220V 72.4 @ 230V 69.4 @ 240V	100.0 @ 220V 95.7 @ 230V 91.7 @ 240V	75.7 @ 220V 72.4 @ 230V 69.4 @ 240V
Current (inrush) (at 50µs) [A] (AC 280V, 90°)	104.0				
Displacement power factor	~1 (0.8 leading ~ 0.8 lagging)				
Total harmonic distortion (THDi, rated power)	<3%				
parallel operation	Yes				
Unbalance output	Yes				

- AC input

Model	X3-AELIO-50K	X3-AELIO-60K	X3-AELIO-49.9K	X3-AELIO-61K	X3-AELIO-49.9K-P
Nominal AC power [W]	50000	60000	49900	61000	49900
Nominal AC current [A]	75.8 @ 220V 72.5 @ 230V 69.5 @ 240V	91.0 @ 220V 87.0 @ 230V 83.4 @ 240V	75.7 @ 220V 72.4 @ 230V 69.4 @ 240V	92.5 @ 220V 88.5 @ 230V 84.8 @ 240V	75.7 @ 220V 72.4 @ 230V 69.4 @ 240V
Max. AC current [A] (above rated current, de-rating is acceptable)	83.4 @ 220V 79.8 @ 230V 76.4 @ 240V	100.0 @ 220V 95.7 @ 230V 91.7 @ 240V	75.7 @ 220V 72.4 @ 230V 69.4 @ 240V	100.0 @ 220V 95.7 @ 230V 91.7 @ 240V	75.7 @ 220V 72.4 @ 230V 69.4 @ 240V
Rated grid voltage (AC voltage range) [V]	3 / N / PE, 220 / 380V 3 / N / PE, 230 / 400V 3 / N / PE, 240 / 415V				
Rated grid frequency [Hz]	50 / 60				

Technical Data

• Battery

Model	X3-AELIO-50K	X3-AELIO-60K	X3-AELIO-49.9K	X3-AELIO-61K	X3-AELIO-49.9K-P
Battery voltage range [V]	160-820				
Recommended battery voltage [V]	650Vdc				
Max.charge / discharge power [kW]	50 / 50	60 / 60	49.9 / 49.9	61 / 61	49.9 / 49.9
Max.charge / discharge current [A]	160 (80*2) (280Ah / 320Ah @ 0.5C)	160 (80*2) (280Ah / 320Ah @ 0.5C)	160 (80*2) (280Ah / 320Ah @ 0.5C)	160 (80*2) (280Ah / 320Ah @ 0.5C)	160 (80*2) (280Ah / 320Ah @ 0.5C)
Peak charge / discharge current [A]	160 (80*2) (280Ah / 320Ah @ 0.5C)	160 (80*2) (280Ah / 320Ah @ 0.5C)	160 (80*2) (280Ah / 320Ah @ 0.5C)	160 (80*2) (280Ah / 320Ah @ 0.5C)	160 (80*2) (280Ah / 320Ah @ 0.5C)
Battery connection	2				
Reverse connect protection	YES				

• EPS output

Model	X3-AELIO-50K	X3-AELIO-60K	X3-AELIO-49.9K	X3-AELIO-61K	X3-AELIO-49.9K-P
EPS peak power [VA]	1.5*Prated, 10s 1.2*Prated, 1min 1.1*Prated, long term				
EPS rated power [kVA]	50.0	60.0	49.9	61.0	49.9
EPS rated voltage [V], frequency [Hz]	3 / N / PE, 220 / 380V, 50/60Hz 3 / N / PE, 230 / 400V, 50/60Hz 3 / N / PE, 240 / 415V, 50/60Hz				
EPS rated current [A]	75.8 @ 220V 72.5 @ 230V 69.5 @ 240V	91.0 @ 220V 87.0 @ 230V 83.4 @ 240V	75.7 @ 220V 72.4 @ 230V 69.4 @ 240V	92.5 @ 220V 88.5 @ 230V 84.8 @ 240V	75.7 @ 220V 72.4 @ 230V 69.4 @ 240V
Max. AC current [A]	83.4 @ 220V 79.8 @ 230V 76.4 @ 240V	100.0 @ 220V 95.7 @ 230V 91.7 @ 240V	75.7 @ 220V 72.4 @ 230V 69.4 @ 240V	100.0 @ 220V 95.7 @ 230V 91.7 @ 240V	75.7 @ 220V 72.4 @ 230V 69.4 @ 240V
Switch time[s]	<10ms				
Total harmonic distortion (THDv, linear load)	<3%				
Parallel operation	Yes				

- Efficiency

Model	X3-AELIO-50K	X3-AELIO-60K	X3-AELIO-49.9K	X3-AELIO-61K	X3-AELIO-49.9K-P
MPPT efficiency	99.90%				
Euro-efficiency	97.20%				
Max. efficiency	98.00%				
Rated battery charge / discharge efficiency	98.5% / 97.00%				

- Protection

Model	X3-AELIO-50K	X3-AELIO-60K	X3-AELIO-49.9K	X3-AELIO-61K	X3-AELIO-49.9K-P
SPD	PV Type II+AC Type II				
AFCI*	Optional (AFCI type: F-I-AFPE-1-4/4/2-3, F-I-AFPE-1-4-3)				

Note:

AFCI Type: F-I-AFPE-1-4/4/2-3

- Full coverage
- Integrated
- AFPE
- 1 monitored string per input port,
- 4/4/2 input ports per channel,
- 3 monitored channels.

AFCI Type: F-I-AFPE-1-4-3

- Full coverage
- Integrated
- AFPE
- 1 monitored string per input port,
- 4 input ports per channel,
- 3 monitored channels.

- Standard

Model	X3-AELIO-50K	X3-AELIO-60K	X3-AELIO-49.9K	X3-AELIO-61K	X3-AELIO-49.9K-P
Safety	EN/IEC 62109-1/-2				
EMC	EN/IEC 61000-6-1/-2/-3/-4; EN/IEC 61000-3-2/-3/-11/-12; EN 55011; IEC 62920;				
Certification	VDE4105, G99, AS4777, EN50549, CEI 0-21, IEC 61727, PEA/MEA, NRS-097-2-1, RD1699, TOR				

Technical Data

- Environment limit

Model	X3-AELIO-50K	X3-AELIO-60K	X3-AELIO-49.9K	X3-AELIO-61K	X3-AELIO-49.9K-P
Protection class	IP66				
Operating temperature range [°C]	-35~60 (Derating above +45°C)				
Relative humidity (condensing) [%]	0~100 (Relative humidity)				
Altitude [m]	<3000				
Storage temperature [°C]	-40~+70				
Noise emission (typical) [dB]	<65				
Over voltage category	PV:II+Main: III				

- General

Model	X3-AELIO-50K	X3-AELIO-60K	X3-AELIO-49.9K	X3-AELIO-61K	X3-AELIO-49.9K-P
Dimensions (WxHxD) [mm]	820x670x257				
Weight [kg]	<100	<105	<100	<105	<105
Cooling concept	Smart air cooling				
Topology	Non-isolated				
Communication	RS485-Meter, RS485-Monitor, RS485-Parallel (daisy-chain), CAN-BMS, CAN-Parallel (daisy-chain), USB, DI*2, DO*1, RCR (DI*4), DRM				
LCD display	Optional				

Note:

The specific gross weight is subject to the actual situation of the whole machine.

Battery system configuration list

No.	Model	BMS	Battery pack	Nominal energy (kWh)	Operating voltage (Vdc)
1	T-HR100.1	TBMS-R15 × 1	TB-HR140 × 7	100.1	292~409
2	T-HR114.4	TBMS-R15 × 1	TB-HR140 × 8	114.4	333~468
3	T-HR128.7	TBMS-R15 × 1	TB-HR140 × 9	128.7	375~526
4	T-HR143.0	TBMS-R15 × 1	TB-HR140 × 10	143.0	416~584
5	T-HR157.3	TBMS-R15 × 1	TB-HR140 × 11	157.3	458~643
6	T-HR171.6	TBMS-R15 × 1	TB-HR140 × 12	171.6	500~701
7	T-HR185.9	TBMS-R15 × 1	TB-HR140 × 13	185.9	541~760
8	T-HR200.2	TBMS-R15 × 1	TB-HR140 × 14	200.2	583~818

Battery system performance parameter

Module	T-HR100.1	T-HR114.4	T-HR128.7	T-HR143.0
Nominal voltage (V)	358.4	409.6	460.8	512
Operating voltage range (V)	292~409	333~468	375~526	416~584
Nominal capacity (Ah) ¹	280	280	280	280
Nominal energy (kWh) ¹	100.1	114.4	128.7	143.0
Usable energy 90% DOD (kWh) ²	90.1	103.0	115.8	128.7
Max. charge/discharge current (A) ³	100	100	100	100
Nominal power (kW)	50.2	57.4	64.6	71.7
Conditional short-circuit current (Icc) (A)	< 10000			
Max. output current (A)	4300 (Duration: 1.21 ms)			
Battery round-trip efficiency (0.2 C, 25°C)	95%			
Relative humidity (% RH)	5 ~ 85%			
Charge temperature	0°C ~ 53°C			
Discharge temperature	-20°C ~ 53°C			
Storage temperature	30°C ~ 50°C (6 months), -20°C ~ 30°C (12 months)			
Ingress protection	IP20			
Protection class	I			
Certificates and approvals	IEC62619, EN62477, UN38.3			

Technical Data

Module	T-HR157.3	T-HR171.6	T-HR185.9	T-HR200.2
Nominal voltage (V)	563.2	614.4	665.6	716.8
Operating voltage range (V)	458~643	500~701	541~760	583~818
Nominal capacity (Ah) ¹	280	280	280	280
Nominal energy (kWh) ¹	157.3	171.6	185.9	200.2
Usable energy 90% DOD (kWh) ²	141.6	154.4	167.3	180.2
Max. charge/discharge current (A) ³	100	100	100	100
Nominal power (kW)	78.9	86.1	93.2	100.4
Conditional short-circuit current (I _{cc}) (A)	< 10000			
Max. output current (A)	4300 (Duration: 1.21 ms)			
Battery round-trip efficiency (0.2 C, 25°C)	95%			
Relative humidity (% RH)	5 ~ 85%			
Charge temperature	0°C ~ 53°C			
Discharge temperature	-20°C ~ 53°C			
Storage temperature	30°C ~ 50°C (6 months), -20°C ~ 30°C (12 months)			
Ingress protection	IP20			
Protection class	I			
Certificates and approvals	IEC62619, EN62477, UN38.3			

Note:

1. Test conditions: 90% DOD, 0.2 C charge & discharge @ +25°C.
2. System usable energy may vary with inverter different setting.
3. Discharge: In case of battery cell's temperature range of -20°C ~ 10°C and 45°C ~ 53°C, the discharge current will be reduced; Charge: In case of battery cell's temperature range of 0°C ~ 25°C and 45°C ~ 53°C, the charge current will be reduced. Product charge or discharge power depends on the actual temperature of the battery cell.
4. The battery can only be discharged and cannot be charged when the battery cell's temperature range is between -20°C and 0°C.

14 Appendix

14.1 Micro-grid Application

14.1.1 Introduction of Micro-grid Application

Due to Islanding Effect, on-grid inverter is unable to work during off-grid. This characteristic makes user losing the on-grid inverter PV energy when off-grid. Micro-grid is the function that making hybrid inverter simulate the grid to active on-grid inverter during off-grid by connecting on-grid inverter to hybrid inverter's EPS terminal.

14.1.2 Wiring Connection Diagram

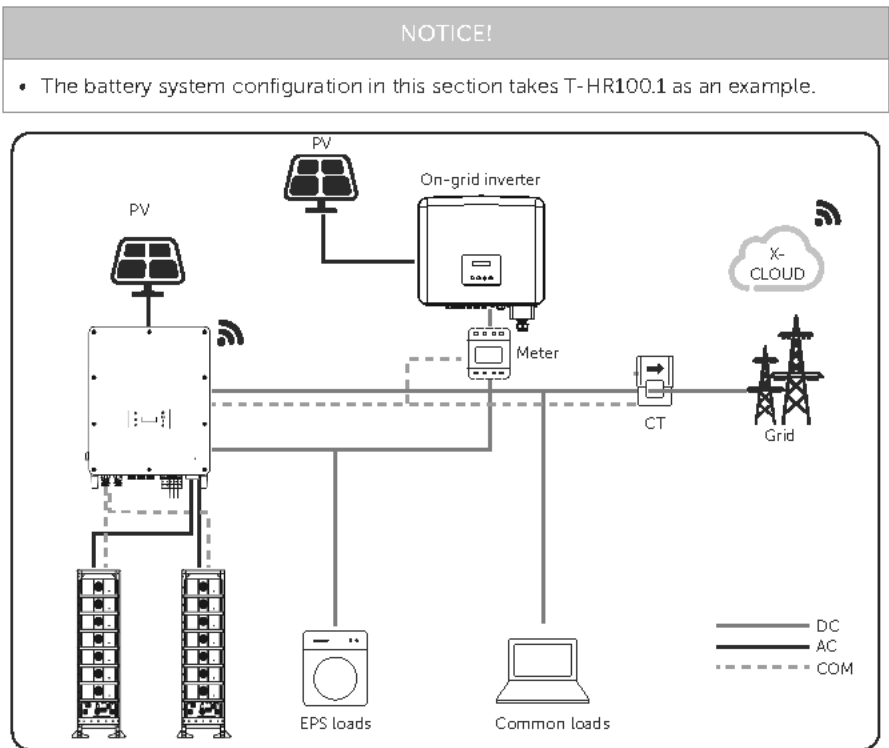

Figure 14-1 Micro-grid wiring connection

14.1.3 Working Modes

Grid on

- When PV is sufficient, the hybrid and on-grid inverters power the general and critical loads together. When there is surplus energy on the on-grid inverter, it will also charge the battery connected to the hybrid inverter.
- When PV is insufficient, the hybrid, on-grid inverter and grid power all the loads.

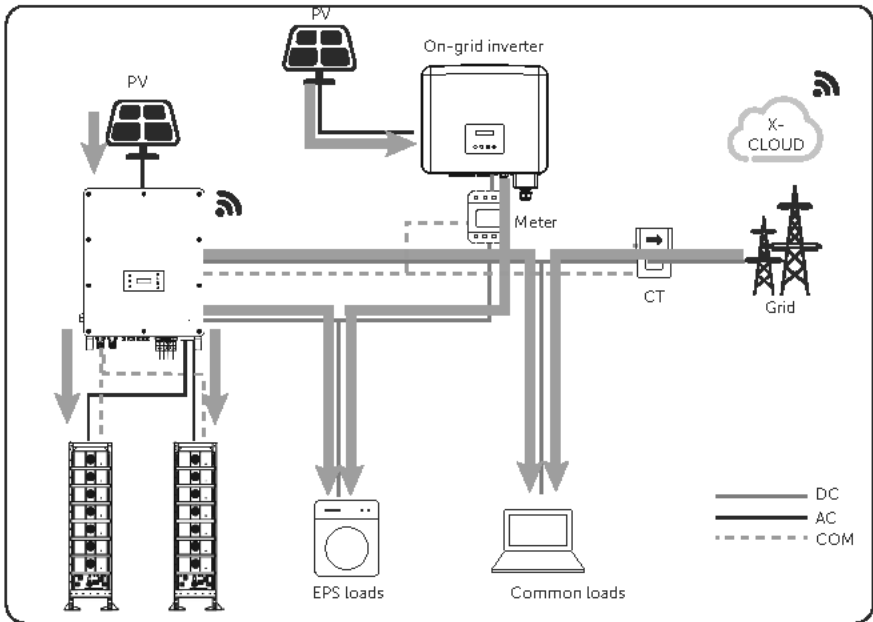

Figure 14-2 Power flowing when grid on and PV sufficient

Grid off

In this case, the hybrid inverter will simulate the grid so as to make the on-grid inverter can still work. Hybrid and on-grid inverter will power the EPS loads together. If there is surplus energy, it will charge the battery.

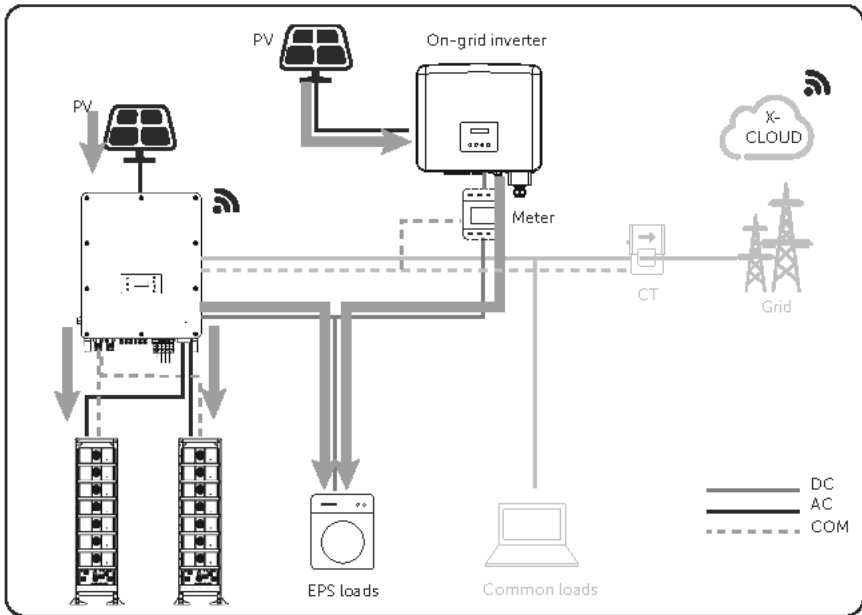

Figure 14-3 Power flowing when grid off

Notice for Micro-grid application

- Any brand of on-grid inverter that supports "frequency adaptation"
- On-grid inverter output power \leq Max hybrid inverter EPS output power
- On-grid inverter output power \leq Max battery charging power, refer to the table below:

NOTICE!

- Since X3-AELIO series inverter is unable to control the output power of on-grid inverter in grid connection mode, therefore X3-AELIO series inverter can not achieve zero export when loads power + battery charging power $<$ on-grid inverter output power.

14.1.4 Cable Connection (Hybrid inverter)

Please refer to "7.3.3 AC Connection" for Grid and EPS connection on X3-AELIO series inverter.

14.1.5 Cable Connection (On-grid Inverter)

Please connect the AC cable of on-grid inverter to the EPS terminal of X3-AELIO series inverter through a circuit breaker. Please refer to the user manual of specific on-grid inverter.

14.1.6 Cable Connection (Meter)

To detect and monitor the power data generated from the on-grid inverter, you can install a meter on the on-grid inverter side. Otherwise, the relevant power data of on-grid inverter cannot be monitored.

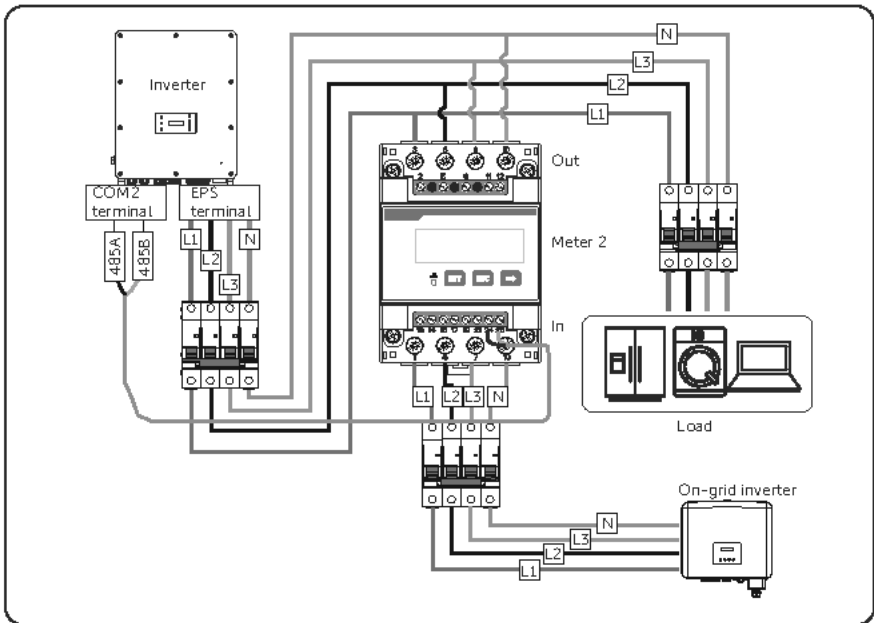

Figure 14-4 Connection diagram of Meter on EPS terminal

NOTICE!

- If one-to-two adapter for RJ45 terminal is used, it should be placed in a waterproof enclosure.

- Pin definition

Table 14-1 Pin definition for meter and CT

Application	For CT1			For meter		For CT2		
Pin	1	2	3	4	5	6	7	8
Assignment	CT_ R1_ CON	CT_ S1_ CON	CT_ T1_ CON	METER _485A	METER _485B	CT_ T2_ CON	CT_ S2_ CON	CT_ R2_ CON

- Meter/CT connection steps

Please refer to “Meter/CT connection” and meter/CT user manual for specific connection steps.

- Setting on the LCD

Setting path: **Menu>Setting>Advance Setting>Meter/CT Setting**

① For meter 1 and meter 2 solution (Meter 1 for girdi connection, Meter 2 for EPS connection)

- Select and enter the **Meter/CT Setting** according the setting path.
- Set the address and direction of Meter 1: You can check the connection status in **Meter/CT Check**.

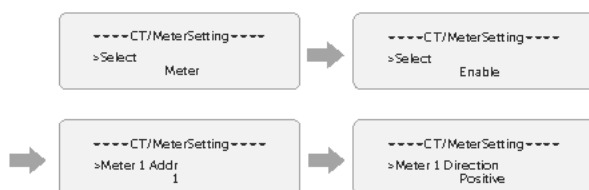

- Set the address and direction of Meter 2: You can check the connection status in **Meter/CT Check**.



- After connection succeeded, check the feed-in power of Meter 1 in the path of **Menu>System Status>Meter/CT** and check the output power (**Output Today** and **Output Total**) of Meter 2 in the path of **Menu>History Data>E_USERDEF**.

② For CT and meter 2 solution (CT for grid connection, Meter 2 for EPS connection)

- a. Select and enter the **Meter/CT Setting** according the setting path.
- b. Select and enable the CT function, select the CT. You can check the connection status in **Meter/CT Check**.



- c. Set the address and direction of Meter 2: You can check the connection status in **Meter/CT Check**.



- d. After connection succeeded, check the feed-in power of Meter 1 in the path of **Menu>System Status>Meter/CT** and check the output power (**Output Today** and **Output Total**) of Meter 2 in the path of **Menu>History Data>E_USERDEF**.

14.2 CT/Meter Connection Scenarios

X3-AELIO inverter series can be connected to a single batch of CTs, a direct-connected meter, or a CT-connected meter, and also supports a Meter 2 function for you to monitor another power generation device at home.

Followings are the detailed wiring and setting procedures of these scenarios. For wiring procedure of the inverter CT/Meter port, see "Meter/CT connection".

14.2.1 Connection of CT

NOTICE!

- Do not place the CT on the N wire or ground wire.
- Do not put CT on the N line and L line at the same time.
- Do not place the CT on the side where the arrow points to the inverter.
- Do not place the CT on non-insulated wires.
- The cable length between CT and inverter should not exceed 10 meters.
- It is recommended to wrap the CT clip around in circles with insulating tape.

NOTICE!

- The CTs referred to in this section are the CT batch delivered with the inverter.

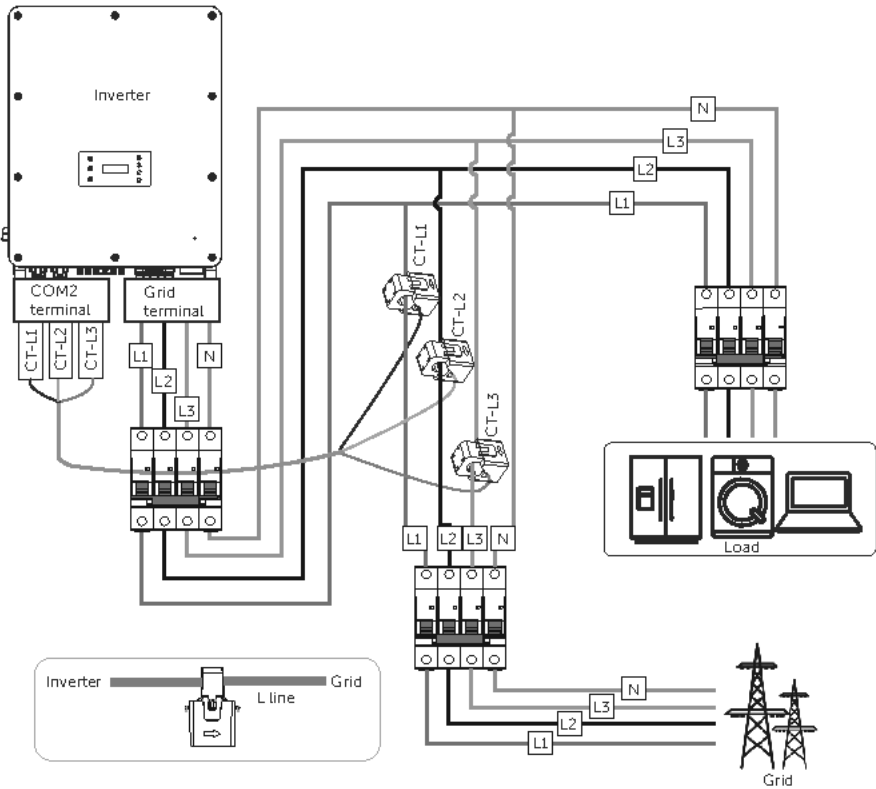

Figure 14-5 System wiring with CT

NOTICE!

- The arrow on the CT must point at the public grid.
- Markings on the CTs might be R, S and T or L1, L2 and L3. Make sure to clip CT-R/CT-L1 to the L1 wire, CT-S/CT-L2 to the L2 wire, and CT-T/CT-L3 to the L3 wire.
- The emergency load is connected to the EPS terminal of the inverter, which is not shown in the diagram.

Wiring procedure

Step 1: Clip CT_L1, CT_L2 and CT_L3 respectively onto the L1, L2 and L3 cables of the grid.

Make sure the arrow on the CTs is pointing to the grid side from the inverter.

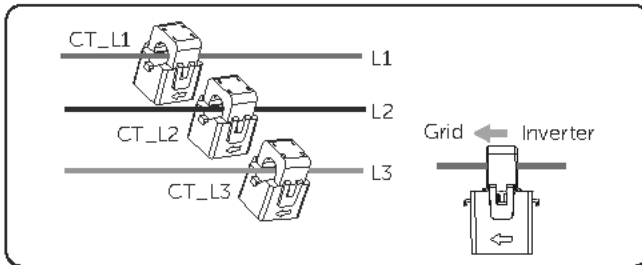

Figure 14-6 Clipping CTs to grid cables

Step 2: Use the RJ45 coupler to connect the extension communication cable and the batch of CTs.

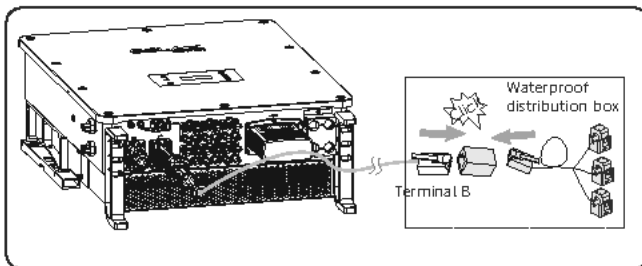

Figure 14-7 Connecting to CT

Setting procedure

After connecting CT to the inverter, set parameters for them on the inverter.

Step 1: Select **Advance Settings > Meter/CT Setting**.

Step 2: Enable CT, and then select the supported CT type.

You can check the connection status in **Meter/CT Check**. For details, see "Setting Meter/CT Check".

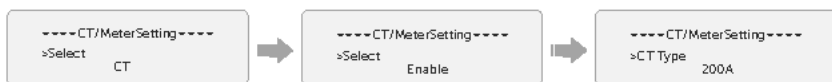

Figure 14-8 Setting CT for the inverter

14.2.2 Connection of Direct-connected Meter

NOTICE!

- The following figures take inverter with Meter DTSU666 as an example.
- Please make PE connection for Meter if the meter has ground terminal.

- Meter connection diagram

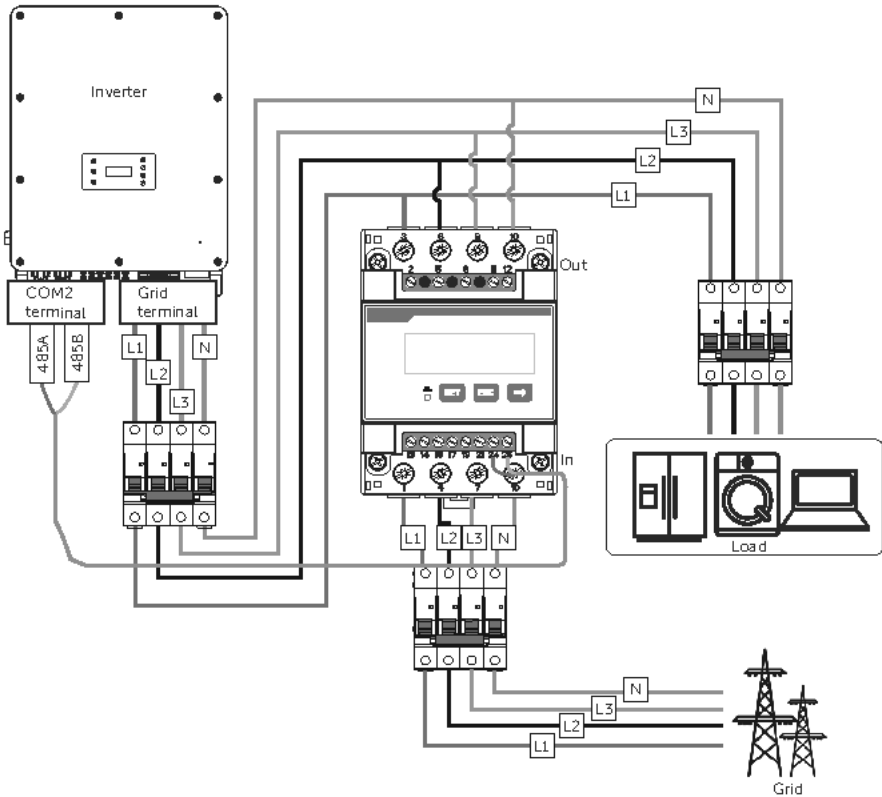

Figure 14-9 System wiring with direct-connected meter

NOTICE!

- For direct-connected meter, the current flow direction should be from grid to the inverter.
- Terminal 1, 4 and 7 of the meter must be connected to the grid side, and terminal 3, 6 and 9 be connected to the inverter side of the system. Otherwise, the system power data might be misread.

Meter terminal definition

Table 14-2 Terminal definition of SolaX direct-connected meter

Terminal No.	Definition	Description
1, 4, 7	UA*, UB*, UC*	Voltage input terminal of phase A, B and C, respectively connected to L1, L2 and L3 wire
3, 6, 9	UA, UB, UC	Voltage output terminal of the three phases, respectively connected to L1, L2 and L3 wire
10	UN	Connected to the N wire
24	RS485A	RS485 terminal A
25	RS485B	RS485 terminal B

Wiring procedure

- Step 1:** Strip around 10 mm wire insulation off the grid voltage cables, and then connect L1, L2 and L3 wires respectively to terminal 1 and 3, 4 and 6, 7 and 9, and N wire to terminal 10 of the meter.

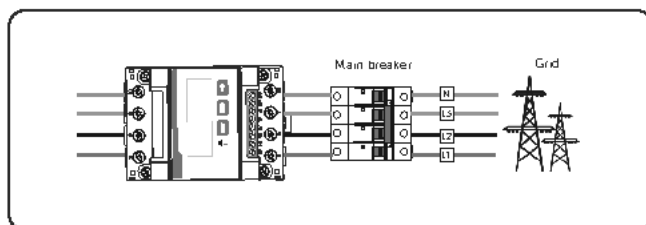

Figure 14-10 Connecting direct-connected meter to the grid

- Step 2:** Strip 15 mm wire insulation off the other end of the communication cable.

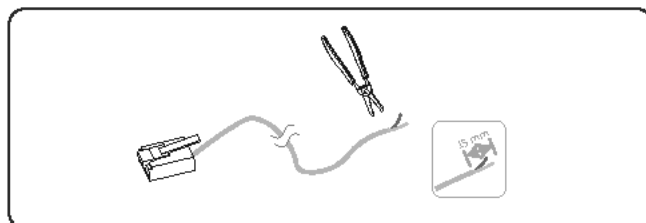

Figure 14-11 Stripping communication cable for meter

Step 3: Connect the conductors to terminal 24 and 25 of the meter.

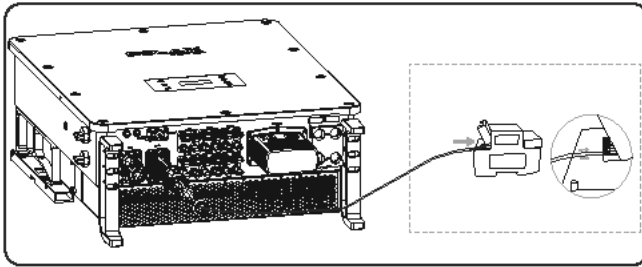

Figure 14-12 Connecting inverter to meter

Setting procedure

After connecting meter to the inverter, set parameters of the meter on the inverter.

Step 1: Select **Advance Settings > Meter/CT Setting**.

Step 2: Enable **Meter**, and then set **Meter1Addr** to **1** and **Meter1 Direction** to **Positive**.

You can check the connection status in **Meter/CT Check**. For details, see "Setting Meter/CT Check".

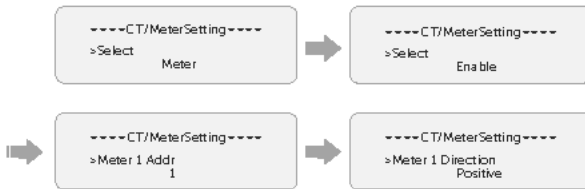

Figure 14-13 Setting meter for the inverter

14.2.3 Connection of CT-connected Meter

NOTICE!

- The following figures take inverter with Meter DTSU666-CT as an example.
- Please make PE connection for Meter if the meter has ground terminal.
- The CTs referred to in this section are CTs that are delivered with the CT-connected meter.

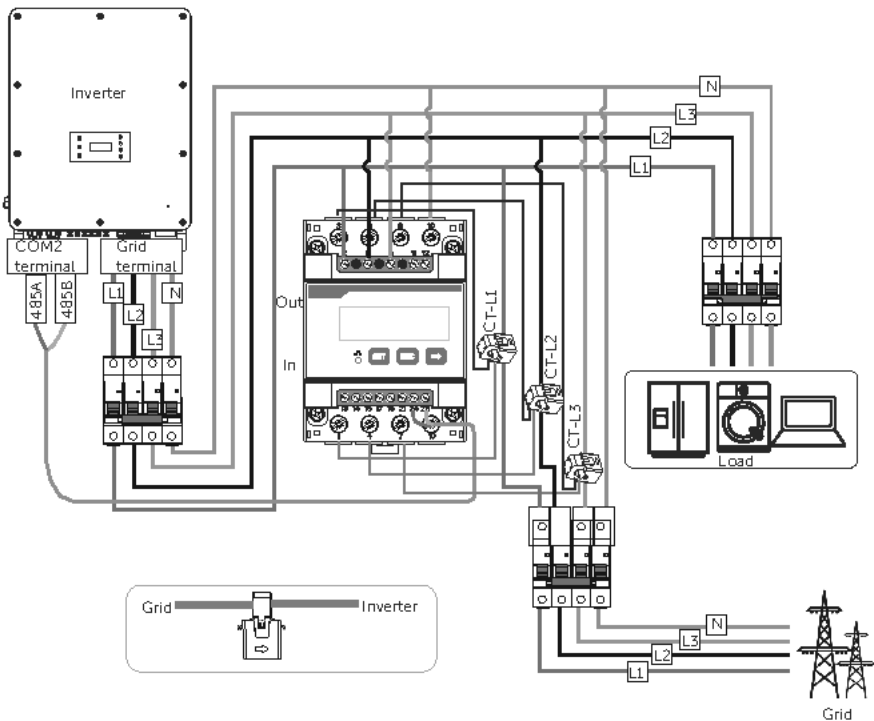

Figure 14-14 System wiring with CT-connected meter

NOTICE!

- Terminal 2, 5 and 8 of the meter must be connected to the grid side. Terminal 1, 4 and 7 must be connected to the S1 wire of the CTs, and terminal 3, 6 and 9 be connected to the S2 wire of the CTs. Otherwise, the system power data might be misread.
- The arrow on the CT must point at the inverter.
- Markings on the CTs might be R, S and T or L1, L2 and L3. Make sure to clip CT-R/CT-L1 to the L1 wire, CT-S/CT-L2 to the L2 wire, and CT-T/CT-L3 to the L3 wire.

Meter terminal definition

Table 14-3 Terminal definition of SolaX CT-connected meter

Terminal No.	Definition	Description
2, 5, 8	UA, UB, UC	Voltage input terminal of phase A, B and C respectively connected to L1 L2 and L3 wire
10	UN	Phase N voltage input terminal, connected to the N wire
1, 4, 7	IA*, IB*, IC*	Current input terminal of the three phases, connected to the S1 wire of CT
3, 6, 9	IA, IB, IC	Current input terminal of the three phases, connected to the S2 wire of CT
24	RS485A	RS485 terminal A
25	RS485B	RS485 terminal B

Wiring procedure

- Step 1:** Strip around 10 mm wire insulation off the voltage cables, and then connect L1, L2 and L3 wires respectively to terminal 2, 5 and 8, and the N wire to terminal 10 of the meter.
- Step 2:** Clip the CTs onto the L1, L2 and L3 wires in the direction from grid to inverter.
- Step 3:** Connect the S1 wire of the three included CTs respectively to terminal 1, terminal 4 and terminal 7, and S2 wire of the CTs respectively to terminal 3, 6 and 9 of the meter.

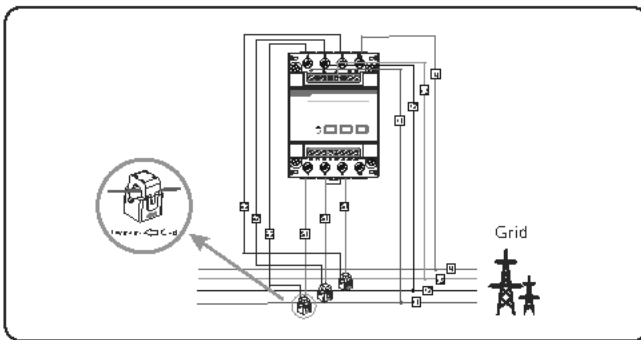

Figure 14-15 Connecting CT-connected meter to the grid

Step 4: Strip 15 mm wire insulation off the other end of the communication cable.

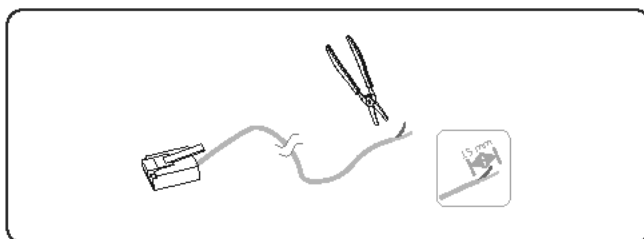

Figure 14-16 Stripping communication cable for meter

Step 5: Connect the conductors to terminal 24 and 25 of the meter.

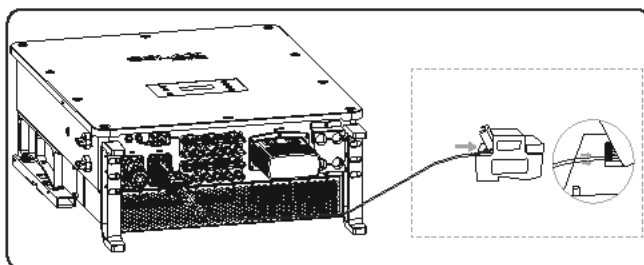

Figure 14-17 Connecting inverter to meter

Setting procedure

After connecting CT to the inverter, set parameters for them on the inverter.

Step 1: Select **Advance Settings > Meter/CT Setting**.

Step 2: Enable **Meter**, and then set **Meter1Addr** to **1** and **Meter1 Direction** to **Positive**.

You can check the connection status in **Meter/CT Check**. For details, see "Setting Meter/CT Check".



Figure 14-18 Setting meter for the inverter

14.2.4 Connection of Two Meters

If you have another power generation device (such as an inverter) at home and wants to monitor both device, our inverter provides a Meter 2 Communication function to monitor the other power generation device.

NOTICE!

- For connecting CT and meter, or connecting two meters, prepare an RJ45 splitter adapter and a proper waterproof enclosure for it in advance.
- The device for monitoring the system (device at Meter 1 position) can be CT, direct-connected meter and CT-connected meter, but the device for monitoring the other power generation device (device at Meter 2 position) can only be meters, either direct-connected meter or CT-connected meter. The following diagrams use the connection of CT and direct-connected meter for example.

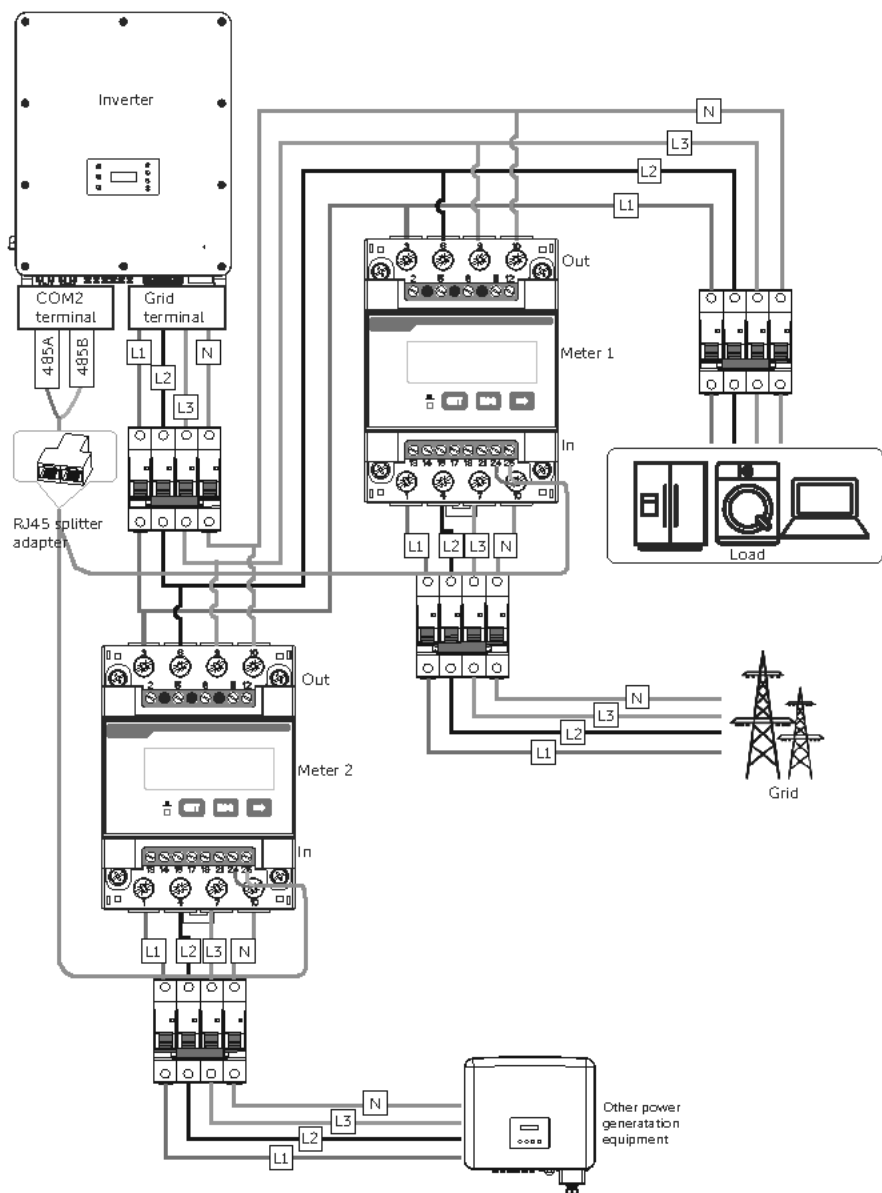

Figure 14-20 Connection diagram of two direct-connected meters

Wiring procedure

Step 1: Follow the above steps to connect the meter, CT and inverter.

Step 2: Connect the RJ45 terminals to the RJ45 splitter adapter.

Setting procedure

After connecting the CT and meter to the inverter, you need to set parameters on the inverter LCD before they can work normally for the system.

Step 1: Select **Advance Settings > Meter/CT Setting**.

Step 2: Set the Meter/CT:

- » **Case 1:** CT and Meter 2 are connected (CT for SolaX inverter, Meter 2 for another power generation device). CT is set by default. Check whether the address and direction of Meter2 are set based on actual connection.

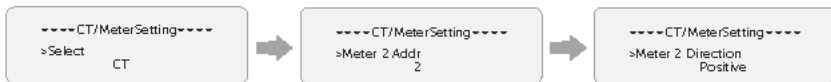

Figure 14-21 Selecting CT and set Meter2 data

- » **Case 2:** Meter 1 and Meter 2 are connected (Meter 1 for SolaX inverter, Meter 2 for another power generation device). Select **Meter** and enable the Meter function. Check whether the address and direction of Meter 1 and Meter 2 are set based on actual connection.

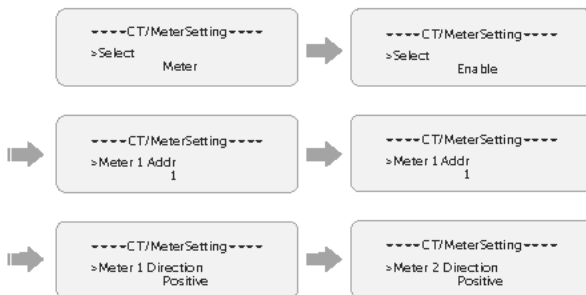

Figure 14-22 Selecting meter and set Meter 1 and Meter 2 data

Step 3: Set the CT type.



Figure 14-23 Setting the limits

Related operation

Setting Meter/CT Check

- **Installation Check:** It is for checking whether the Meter/CT has been correctly connected. It is vital to the normal function of the whole system. Therefore, we recommend performing installation check after connecting the Meter/CT.

Select **Meter/CT Setting > Meter/CT Check**, and then enable **Installation Check**.

The system will perform Meter/CT check immediately after you enable it, and then automatically restores to the disabled status after the check completes.



- **Cyclic Check:** It is for periodically checking whether the Meter/CT is in good condition when the inverter is running.

Select **Meter/CT Setting > Meter/CT Check**, and then enable **Cyclic Check**.

Once Cyclic Check is enabled, the system will check the Meter/CT status periodically based on the defined cycle.



Figure 14-24 Checking Meter/CT status

14.3 Capacity Expansion

! DANGER!

- Before conducting cable connections, ensure that the system is powered off. Otherwise, electric shocks may occur.
- After the system powers off, there will still be the remaining electricity and heat which may cause electric shocks and body burns. Please wear personal protective equipment (PPE) and begin servicing the system 15 minutes after power off.
- Only qualified person can perform the capacity expansion operation.

NOTICE!

- The device is allowed to increase the number of battery packs to achieve capacity expansion. One inverter can connect to two high-voltage boxes.
- Please confirm that there is enough space to increase the number of battery packs.
- Please make sure that the foundation that are used to install new battery packs can handle the additional weight.
- Users need to prepare positive and negative power cables (conductor cross-section: $26.7 \pm 2 \text{ mm}^2$) based on the distance between the inverter and high-voltage box.

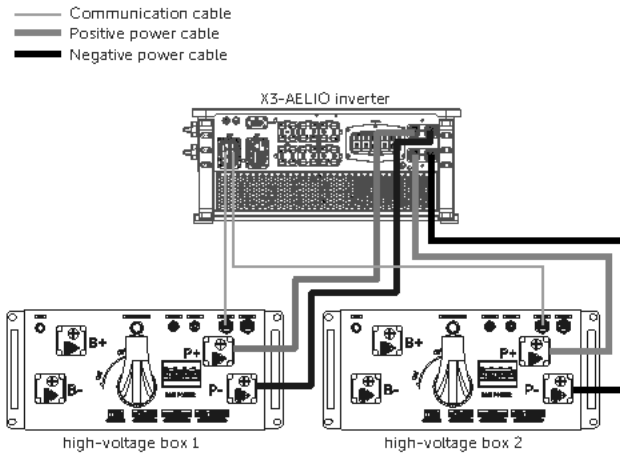

Figure 14-25 Wiring diagram of capacity expansion

Wiring procedure of Battery 1

Before wiring for capacity expansion, please remove positive power cable and negative power cable between the high-voltage box and inverter. Please do as follows:

Step 1: Remove the negative power cable from the high-voltage box.

- a. Remove the cover of P- port of high-voltage box.
- b. Unscrew M8 screws with a torque wrench.
- c. Remove the negative power cable.
- d. Insert and tighten M8 screws with a torque wrench (torque: 12 ± 1.2 N·m). Reinstall the cover.

Step 2: Remove the positive power cable in the same way.

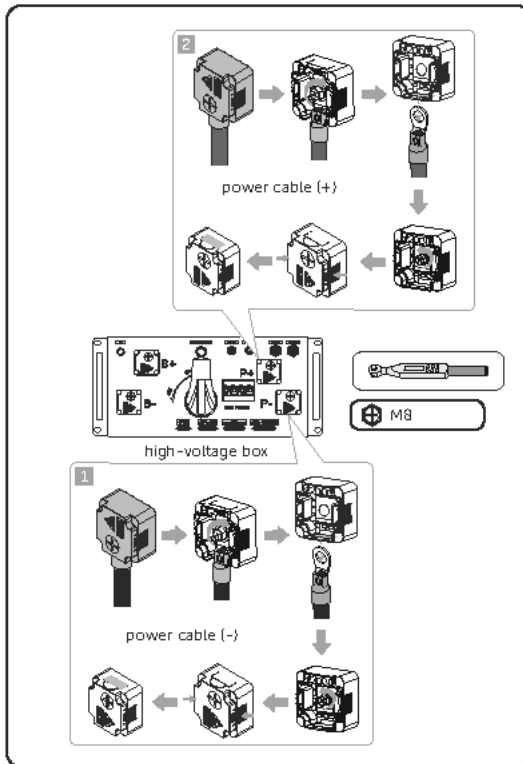

Figure 14-26 Removing power cables

- Step 3:** Loosen the screws on the battery protective cover of the inverter and remove the cover. Pull out the battery caps.

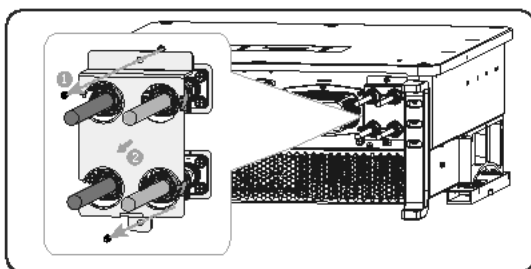

Figure 14-27 Removing the battery protective cover

- Step 4:** Pinch the tab on the sides of the battery connectors of the inverter and pull it at the same time to disassemble the battery connectors of the inverter.

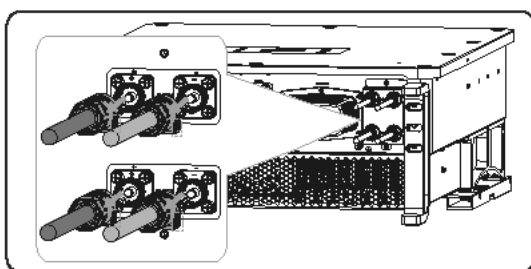

Figure 14-28 Removing the battery connectors

- Step 5:** Crimp the power cable terminals on the battery side:

- a. Take out the power cables, and with care, strip the cable jacket about 17 ± 1 mm from the end.

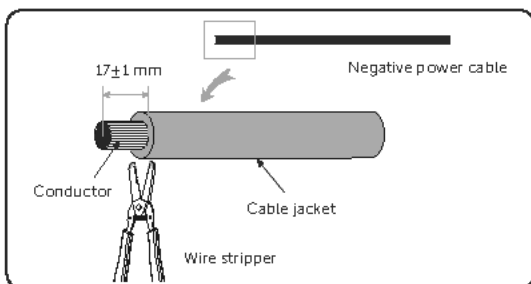

Figure 14-29 Stripping power cable

NOTICE!

- DO NOT damage the conductor while sliding the jacket off the power cable end.

- b. Cut the heat-shrinking tubing to about 20-25 mm long, carefully slide it onto the end of the cable, and then carefully lip the wires all the way into the ring terminal (Part A4).

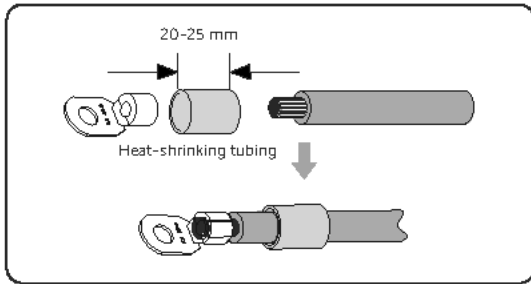

Figure 14-30 Cutting heat-shrinking tubing

- c. Crimp the terminal, and heat the heat-shrink tubing after it wraps the end of terminal.

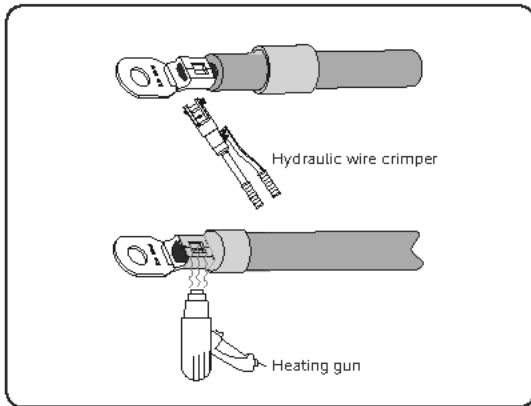

Figure 14-31 Crimping and heating terminal

NOTICE!

- Properly place the ring terminal into the hydraulic wire crimper.

- d. Make the positive power cable according to the above two steps.

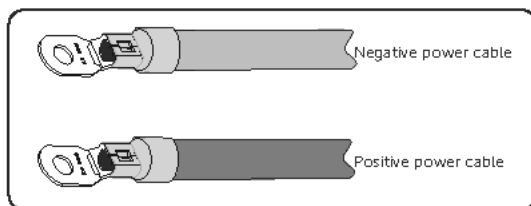

Figure 14-32 Making power cables

Step 6: Crimp the power cable terminals on the inverter side:

- a. Disassemble the battery connectors (Part C4 and Part D4).

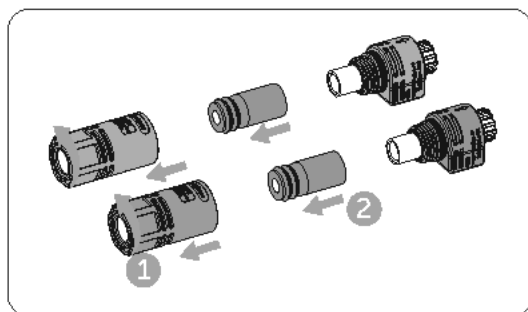

Figure 14-33 Disassembling battery connectors

- b. Thread the battery power cable through the swivel nut and then the cable support sleeve. Strip 15 ± 1 mm insulation off.

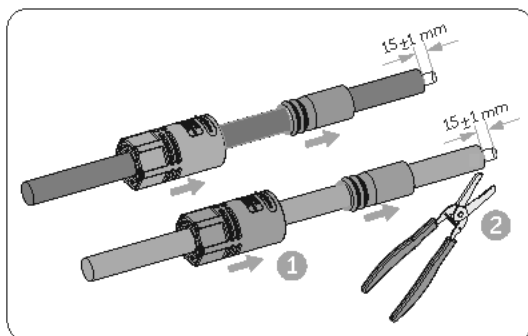

Figure 14-34 Stripping the battery power cable

- c. Insert the stripped cable into the connector enclosure. Ensure that the stripped cable and the enclosure are of the same polarity. Crimp it with a hydraulic plier at 7.2 ± 0.2 mm and ensure that the exposed core of the cable is no more than 1 mm.

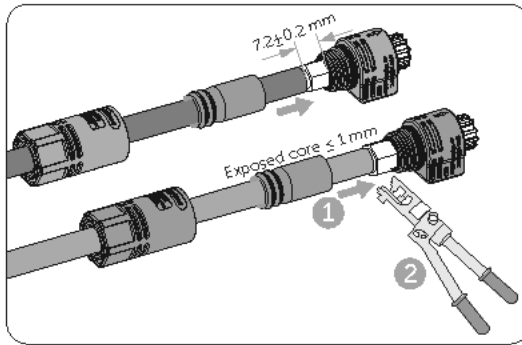

Figure 14-35 Crimping the terminal

NOTICE!

- Before the battery power cables are stripped, please ensure that the exposed core of cables should be less than 1 mm when the battery connectors are crimped.

- d. Pull the cable support sleeve over the crimped battery connector enclosure and then the swivel nut to the enclosure. Tighten the swivel nut.

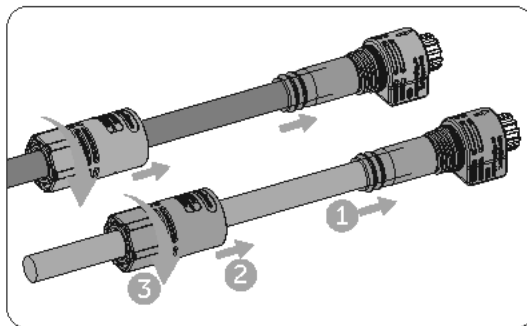

Figure 14-36 Tightening the battery connector

Step 7: Connect the negative power cables between the high-voltage box and inverter.

- Remove the cover of P- ports of high-voltage box.
- Unscrew M8 screws and insert the terminal of negative power cables into P- ports.
- Insert and tighten M8 screws with a torque wrench (torque: 12 ± 1.2 N·m).
- Reinstall the cover.
- Thread the cables through the cable tie mount on the cable tray bracket.

Step 8: Connect the positive power cable in the same way.

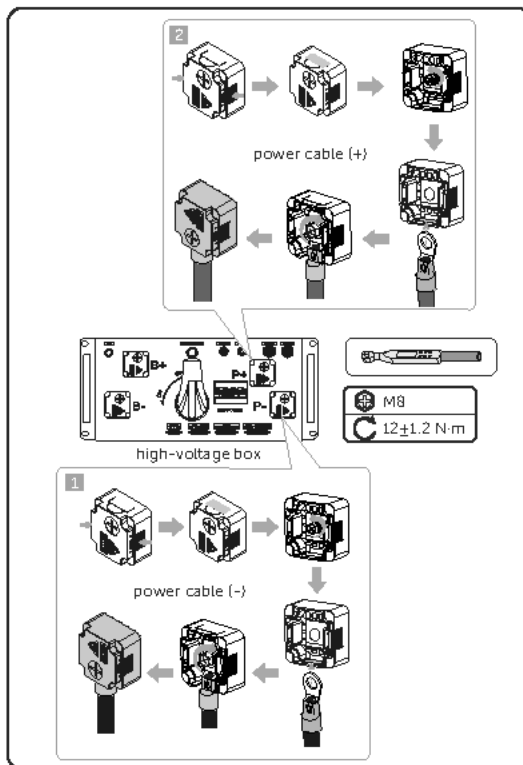

Figure 14-37 Power cables connection

Step 9: Connect the battery connectors to **BAT1+** and **BAT1-** of inverter until there is an audible "Click". The BAT+ on the string side must be connected to the BAT+ on the inverter side, and the BAT- on the string side must be connected to the BAT- on the inverter side. Gently pull the cable backward to ensure firm connection.

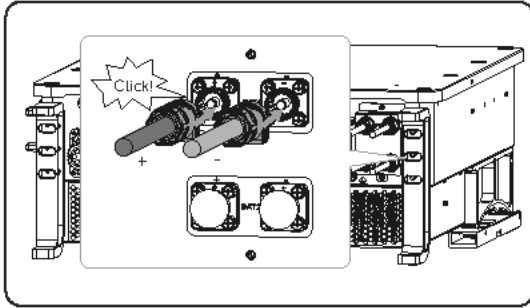

Figure 14-38 Connecting assembled battery cables

Step 10: Loosen the screw on the COM 1 connector of the inverter. Pinch the tabs on the sides of the COM 1 connector enclosure and pull it at the same time to disassemble it.

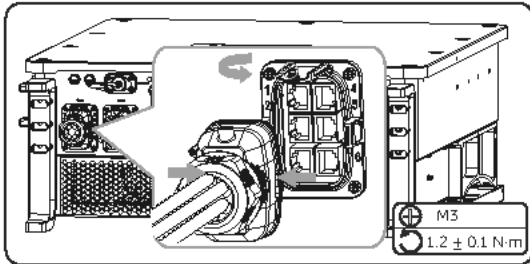

Figure 14-39 Removing COM 1 connector

Step 11: Anti-clockwise loosen the swivel.

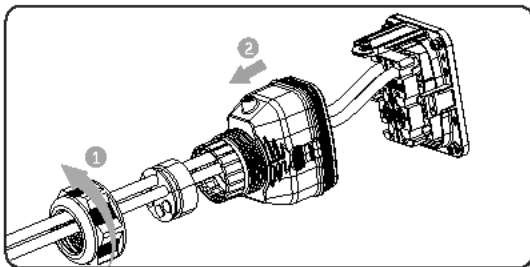

Figure 14-40 Loosen the swivel

Wiring procedure of Battery 2

- Step 1:** As for the connection procedure about the power cables between high-voltage box and inverter, please refer to "Wiring procedure of Battery 1" step 1 ~ step 8.
- Step 2:** Plug one side of the communication cable (Part B4) into the **PCS COM** terminal of the high voltage box.

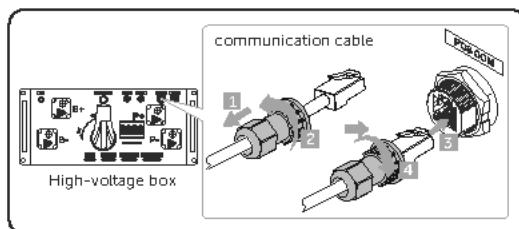

Figure 14-41 High voltage box side wiring

- Step 3:** Connect the battery connectors to **BAT2+** and **BAT2-** of inverter until there is an audible "Click".

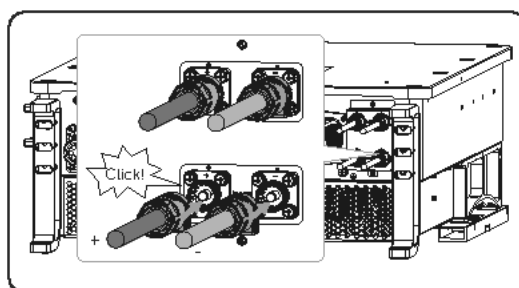

Figure 14-42 Connecting assembled battery cables

- Step 4:** After the battery cables are connected, install the battery protective cover and secure the cover on the inverter with screws.

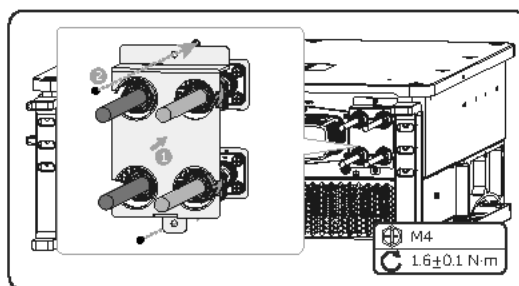

Figure 14-43 Installing the battery protective cover

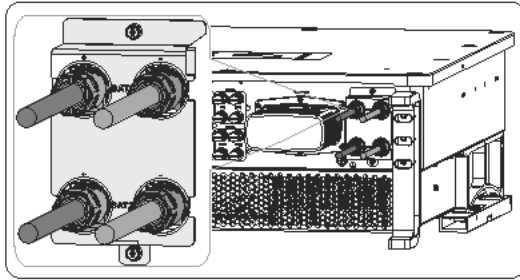

Figure 14-44 Well connected battery cables

Step 5: Thread the other side of the communication cable through the swivel nut, cable support sleeve and connector enclosure of the COM 1 connector of the inverter in sequence.

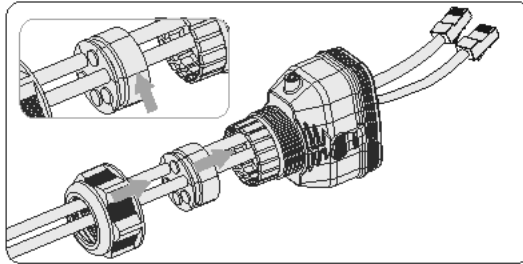

Figure 14-45 Threading the cables with RJ45 terminal

Step 6: Install the network cables to BMS-1 and BMS -2 of cable clamp according to the labeling.

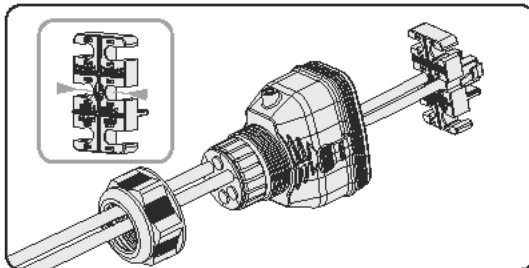

Figure 14-46 Installing RJ45 terminal to the cable clamp

- Step 7:** Secure the assembled connector on COM 1 terminal.
- Install the connector enclosure back into the COM 1 terminal.
 - Install the cable support sleeve into the enclosure.
 - Tighten M3 screw to secure it. (Torque: $1.2 \pm 0.1 \text{ N}\cdot\text{m}$)
 - Clockwise tighten the swivel nut to finish the COM 1 wiring connection.

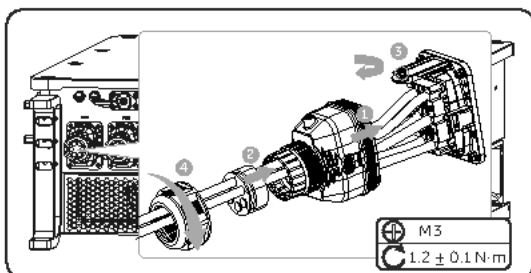







Figure 14-47 Securing the connector

Contact Information

UNITED KINGDOM

 Unit C-D Riversdale House, Riversdale
Road, Atherstone, CV9 1FA
 +44 (0) 2476 586 998
 service.uk@solaxpower.com



TURKEY

 Fevzi Cakmak mah. aslim cd. no 88 A
Karatay / Konya / Turkiye
 service.tr@solaxpower.com



USA

 3780 Kilroy Airport Way, Suite 200, Long
Beach, CA, US 90806
 +1 (408) 690 9464
 info@solaxpower.com

POLAND

 WARSAW AL. JANA P. II 27. POST
 +48 662 430 292
 service.pl@solaxpower.com

ITALY

 +39 011 19800998
 support@solaxpower.it



PAKISTAN

 service.pk@solaxpower.com





AUSTRALIA

 21 Nicholas Dr, Dandenong South VIC 3175
 +61 1300 476 529
 service@solaxpower.com.au



GERMANY

 Am Tullnaupark 8, 90402 Nürnberg,
Germany
 +49 (0) 6142 4091 664
 service.eu@solaxpower.com
 service.dach@solaxpower.com



NETHERLANDS

 Twekkeler-Es 15 7547 ST Enschede
 +31 (0) 8527 37932
 service.eu@solaxpower.com
 service.bn1@solaxpower.com

SPAIN

 +34 9373 79607
 tecnico@solaxpower.com

BRAZIL

 +55 (34) 9667 0319
 info@solaxpower.com

SOUTH AFRICA

 service.za@solaxpower.com



SolaX Power Network Technology (Zhejiang) Co., Ltd.

Add.: No. 278, Shizhu Road, Chengnan Sub-district, Tonglu County,
Hangzhou, Zhejiang, China
E-mail: info@solaxpower.com

