

CE



Instructions for installation, use and maintenance – ENG

EI Cm Basic

Electric boiler for heating

Content

1. Explanation of symbols and instruction for safe work

2. Device data

- 2.1. Typology
- 2.2.1 Statement on conformity
- 2.2.2 Regular use
- 2.3 Installation instruction
- 2.4 Work instruction
- 2.5 Inhibitors and anti- freezers
- 2.6 Norms, regulations and standards
- 2.7 Tools, materials and ancillary resources
- 2.8 Minimum distance and incendiary of construction materials
- 2.9 Product description
- 2.10 Waste disposal
- 2.11 Supply range
- 2.12 Manufacturer plate
- 2.13 Transportation

3. Dimensions and technical data

4. Device installation

- 4.1 Caution when installing
- 4.2 Distances
- 4.3 Front casing demounting
- 4.4 Boiler installation
- 4.5 Hydraulic connections
- 4.6 Filling the installations and permeability testing
 - 4.6.1 Filling the boiler with water and sealing testing
 - 4.6.2 Heating pump air vent and unlocking
 - 4.6.3 Air vent of boiler and installations

5. Electric connection

- 5.1 Position of connectors and connecting voltage cable
- 5.2 Connecting voltage cable
- 5.3 Voltage cable connecting scheme
- 5.4 Connecting external boiler control (room thermostat)
- 5.5 Electric schemes

6. Commissioning

- 6.1 Before commissioning
- 6.2 First commissioning
- 6.3 Minute Book on Commissioning

7. Handling heating installation

- 7.1 Work instruction
- 7.2 Adjusting elements review
- 7.3 Room thermostat
- 7.4 Heating interruption
- 7.5 Switch off the boiler

8. Cleaning and maintenance

- 8.1 Cleaning the boiler
- 8.2 Working pressure check, water refill and air vent of installations
- 8.3 Water refill and air vent of installations
- 8.4 Minute book on inspection and maintenance



9. Environment protection / Waste management

10. Troubles and Troubleshooting

1. Explanation of symbols and instruction for safe work

1.1 Explanation of symbols

Warnings

	The warning triangle with grey background and framed means a warning within the given text
	Danger of electric power shock is marked with the thunderbolt symbol in warning triangle

Signal words at the beginning of a safety notification means modus and seriousness of consequences that can occur if not apply measures for preventing danger.

- **NOTE** means possible minor material damage.
- **CAUTION** means possible minor to middle injuries.
- **WARNING** means possible hard injuries.
- **DANGER** means possible hard injuries.

Important information



Important information meaning danger for people and things, are marked by symbol illustrated in the following text.

It is framed by lines above and below text.

Other symbols

Symbol	Meaning
▶	Step of action
→	Direction to other points in document or other documents
•	Enumeration/Enter from list
–	Enumeration/Enter from list (2.)

Table 1

1.2 Instruction for safe work

General safety instructions

Failure to respect safety instructions can lead to heavy injuries – and to the lethal outcomes, material and environmental damage.

- Professional inspection of electric installations should be secured before installing this device.
- All electric works should be done by person authorized for such works according to the relevant regulations.
- Make sure that commissioning, maintenance and repairs are done only by the competent service.
- Make sure you have provided technical handover of installations in accordance with relevant regulations.

Danger in case of emergency, for example in case of fire, due to disrespect of own security.

- Never expose to life threat. Own security is always priority.

Damage due to wrong handling

Wrong handling can lead to injuries and/or installation damage.

- Only persons authorized to work correctly with device can have access to the device
- Only authorized service must perform commissioning, maintenance and repair of device with proper certification for electric works.

Installation and commissioning

- Only authorized service can place the device.
- Boiler can be started only if installation is with proper pressure level with neat working pressure. Safety valves must not turn on in order to avoid damage caused by too high pressure. During heating water can leak on safety valve within the hot water circuit and hot water pipes.
- Install this device only in a room safe from freezing.
- do not store or dispose combustible materials or liquids near this device.
- Keep safe distance according to valid regulations.

Life threat of electric power shock

- ④ Electric power connection installation should be done only by authorized service. Follow up with connection schemes.
- ④ Before all works: turn off electric power supply. Prevent accidental turn on.
- ④ Do not install this device in humid rooms.

Inspection / Maintenance

- ④ Recommendation for user: Conclude an agreement on maintenance with authorized servicer who will perform annual maintenance and inspections.
- ④ User is responsible for safety and ecological conformity of the installation.
- ④ Make sure you follow up with instructions for safe work given in the section 'Cleaning and maintenance'.

Original spare parts

No responsibility will be undertaken for damage due to spare parts not provided by the manufacturer.

Use only original spare parts.

Material damage due to freezing

- ④ When there occur freezing risk exhaust water from the boiler, tank and heating pipeline. Freezing danger does not exist only when the entire installation is empty.

Instruction for servicer

- ④ Inform users about the way this device works as well as about maintenance.
- ④ Users must not repair or make alternations alone.
- ④ Warn users not to allow children access to heating installations without escort of adults.
- ④ Fill in the Commissioning document and Log Book on Handover enclosed to this document.
- ④ Technical documentation should be submitted to a user.

Waste management

- ④ Packaging should be disposed in ecologically Acceptable way
- ④ Device should be disposed in ecologically acceptable way in authorized disposing place.

Cleaning

- ④ Clean device externally by wet cloth

2. Data about device

These instructions consist of important information about safety and professional installation, commissioning and maintenance of the boiler.

These instructions are aimed to installers who have knowledge to work with heating installations based on their professionalism and experience.

2.1 Typology

This manual relates to the following type:

El-Cm Basic	6 – 45 kW
--------------------	-----------

2.2.1 Statement on conformity

We hereby declare that devices are tested in accordance with directives 2006/95/EC (low voltage directive LVD and 2004/108/EC - directive on electric magnetic compatibility EMC)

2.2.2 Regular use

The boiler must be used only for water heating for the heating system and for indirect preparation of hot water. In order to secure regular use it is necessary to comply with instruction manual, data on the manufacturer plate and technical data.

2.3 Installation instructions



Use only original manufacturer's spare parts or spare parts approved by the manufacturer. For damage occurred due to spare parts not supplied by the manufacturer shall not be born any responsibility.

Please follow up the following instructions when mounting heating installations:

- Comply with valid construction regulations.
- Comply with regulations and norms on safety-technical equipment for heating installations.
- Alternations at the site in accordance with valid regulations.

2.4 Work instruction

When working with heating installations please respect the following instructions:

- ④ Boiler should work in the area with maximum temperature Of 80°C, with minimum pressure of 0.5 bars and maximum pressure 3 bars including regular pressure control.
- ④ Boiler must be handled only by adults familiar with instructions and working modus for boiler.
- ④ Keep the safety valve open
- ④ Combustible things must not be put on the boiler or near it (within safety distance).
- ④ Surface of the boiler can be cleaned only by non-combustible cleansers.
- ④ Do not keep combustible things in the room for the boiler mounting (e.g. petroleum, oil).
- ④ No one lid must open during the work process.
- ④ Keep safe distance according to valid local regulations

2.5 Inhibitors and anti-freeze products

It is forbidden to use anti-freezing products or inhibitors. If not possible to avoid use of anti-freezing products there should be applied only products allowed for heating installations.

Use of anti-freezing products:



- ④ It reduces lifetime of the boiler and its parts.
- ④ It reduces heat transmission.

2.6 Norms, regulations and standards

Product is conformed to the following norms and regulations:

- EN 50110-1:2003 – Handling and work with electric installations
- EN 55014:2001 – Electric and magnetic compatibility – terms for household devices, electric devices and similar devices
- EN 60 335-1+ed.2:2003 Electric household devices
- EN 60 335-1+ed.2 zm.A1:2005 Electric household devices
- EN 61000-3-2 ed.3:2006 Electric and magnetic compatibility (EMC) – Limits for pollution emission
- EN 61000-3-3:1997 Electric and magnetic compatibility (EMC) – Law on limitations for voltage changes and low voltage network instability.

2.7 Tools, materials and ancillary resources

Standard tools for fixing of heating, water supply and electric installations are needed for installing and maintenance of the boiler.

2.8 Minimum distance and incendiary of construction materials

Depending on valid regulations there can be applicable some other minimum distances, different than those mentioned in the following text.

- ④ To comply with regulations on electric installations and minimum distances that are valid in certain countries.
- ④ Minimum distance for hardly combustible and self-burning materials is of 200mm.

Flammability of integral elements		
A	Not-burnable	
A1:	Not-burnable	Asbestos, stone, wall ceramic tile, baked clay, plaster, (without organic ingredients)
A2:	With less quantity of ignitable elements (organic ingredients)	Plaster cardboard panels, basalt felt panels, glass fibres, panels made of ALUMIN, ISOMIN; RAJOIT, LOGNOS, VELOX and HERAKLI-T
B	Burnable	
B1:	Hard ignitable	Beech, oak, veneered wood, felt, panels of HOBREX, VERSALIT and UMAKART
B2:	Normally ignitable	Pine, larch and spruce, veneered wood
B3:	Ignitable	Asphalt, cardboard, cellulose materials, tar-paper, plywood panels, cork, polyurethane, polystyrene, polyethylene, floor fibre materials

Table 2: Flammability of integral elements according to DIN 4102

2.9 Product description

Main integral parts of the boiler are the following:

- Boiler body
- Device sheeting and boiler mantle
- Control panel

The boiler can be installed as integral part of the heating system, central heating, hybrid or accumulation systems.

The boiler contains of closed housing made of steel metal sheet with temperature insulation. The boiler is to be fixed on a wall using supplied installation set. Installed temperature insulation in the boiler mantle reduces temperature loss; and at the same time protects against noise. Safety elements (Control panel fuse, temperature regulator) are placed at the top of the boiler.

Depending on the boiler type, there are applied different heating elements. The heating element effects can be adjusted upon grades. Setting of different grades of effects can be obtained via control panel. Number and division of effect grades are visible in the technical data (↗ Section 2.13.2)

2.10 Waste disposal

- ④ Packaging should be disposed in ecologically acceptable way
- ④ Components that should be replaced dispose in ecologically acceptable way

2.11 Supply range

When deliver the boiler, comply with the following:

- ④ Check if the packaging is damaged during delivery.
- ④ Check if delivery is in full and complete.

Part	No. of pcs
Boiler EI-Cm Basic	1
Installation set	1
Instructions for handling	1

2.12 Manufacturer plate

Manufacturer plate is placed at external side of the boiler and contains the following technical data:

- Boiler type
- Serial number
- Power
- Input power
- Temperature maximum
- Working pressure
- Mass
- Electric power supply
- Protection level
- Manufacturer name

2.13 Transportation

	<p>NOTE: Transportation damages</p> <ul style="list-style-type: none"><input type="checkbox"/> Pay attention on transportation instructions Enclosed on the packaging<input type="checkbox"/> Use convenient transportation means, e.g. trolleys For bag with tape; during transportation, the Product should be in horizontal position <input type="checkbox"/> Avoid blows and collisions.
---	---

- Packed boiler put on trolley for bags, if needed secure it by tape and transport it to installation place.
- Remove packaging supplements
- Remove packaging material from the boiler in ecologically acceptable way

3. Dimensions and technical data

3.1 Dimensions of the boiler EI-Cm Basic

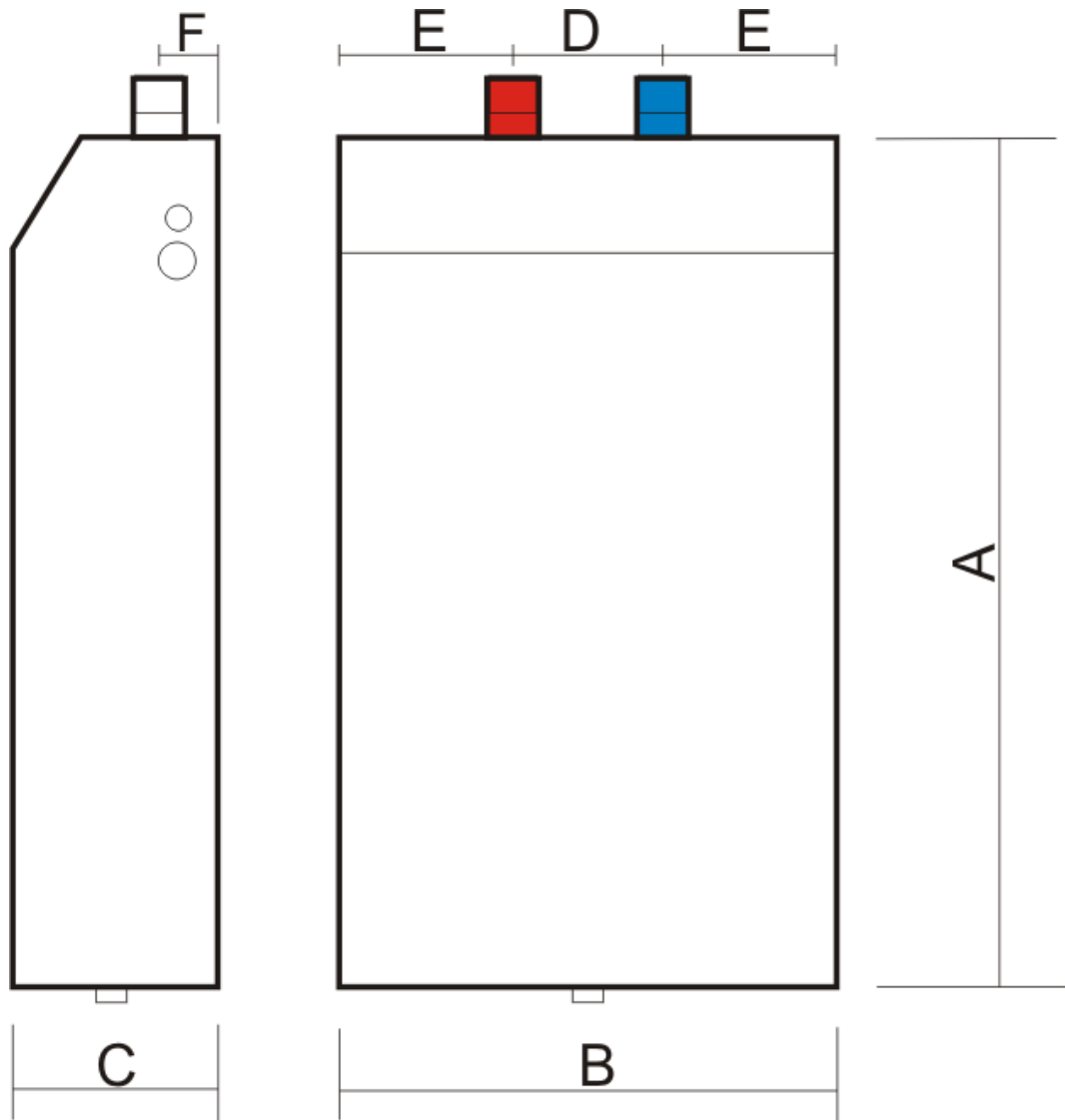

Figure 1: Dimensions and connections EI-Cm Basic 6 – 45 kW

	A	B	C	D	E	F
Basic 6 – 12 kW	620	320	125	90	115	45
Basic 18 – 27 kW	620	370	160	90	140	45
Basic 30 – 45 kW	710	540	180	90	225	45

Table 3: Dimensions (mm) EI-Cm Basic 6 – 45 kW

3.1.1. Components

- | | | | |
|---|-----------------------|----|------------------------------|
| 1 | Boiler mantle | 8 | Contactor |
| 2 | Boiler exchanger | 9 | Main switcher (on/off) |
| 3 | Electric heaters | 10 | Working thermostat |
| 4 | Boiler starting duct | 11 | Switcher of heating elements |
| 5 | Boiler returning duct | 12 | safety thermostat (STB) |
| 6 | Clamp of power cable | 13 | Signal diode |
| 7 | Ancillary clamp | 14 | Connection 1/2" UN |

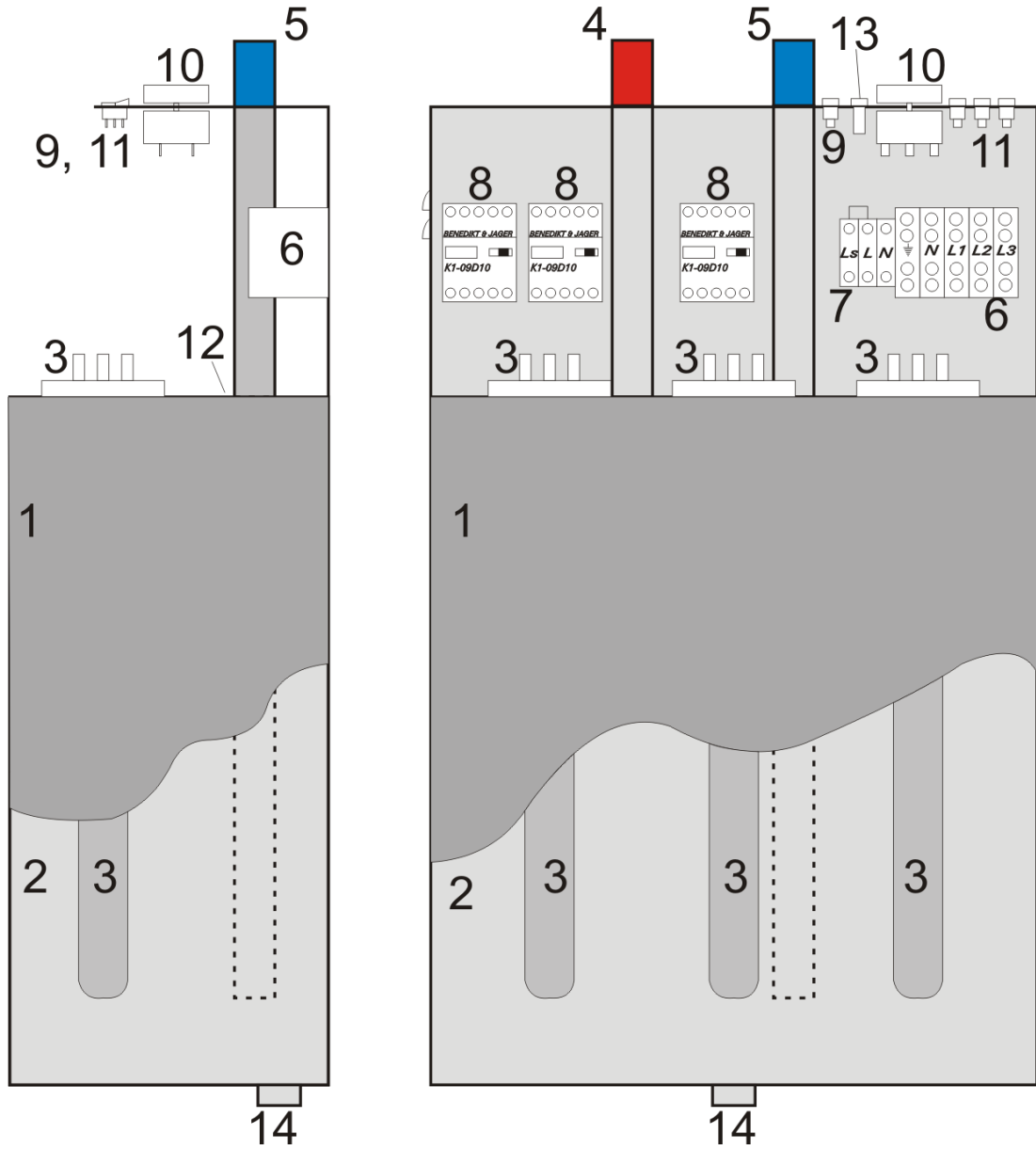

Figure 1: Open boiler view

3.2.1 EI-Cm Basic 6-36 kW Technical data

	Unit	Basic 6	Basic 9	Basic 12	Basic 18	Basic 24	Basic 27	Basic 30	Basic 36
Power	kW	6	9	12	18	24	27	30	36
Usability degree	%	99	99	99	99	99	99	99	99
Number of power degrees		3	3	3	3	3	3	3	3
Power degrees division	kW	1×6	2×4.5	2×6	3×6	3×8	3×9	12+12+6	18+9+9
Mains power	V AC	3N ~ 400/230V 50Hz							
Protection level		IP40							
Needed fuses	A	16 (32M.F)	20 (50M.F)	25	32	40	50	50	63
Cable cross-section min	mm ²	5×2.5 (3×4M.F)	5×2.5 (3×6M.F)	5×4	5×4	5×6	5×6	5×10	5×10
Allowed working pressure max	bar	3.0							
Allowed working pressure min	bar	0.5							
Boiler temperature max	°C	80							
Water volume in boiler	ℓ	10	10	10	20	20	20	32	32
Input cable connection		DN25	DN25	DN25	DN25	DN25	DN25	DN30	DN30
Returning cable connection		DN25	DN25	DN25	DN25	DN25	DN25	DN30	DN30
Device mass (Without water)	Kg	14	15	15	20	20	20	30	30

Table 4a: Technical data EI-Cm Basic 6-36 kW

3.2.2 Technical data: EI-Cm Basic 40-45 kW

	Unit	Basic 40	Basic 45
Power	kW	40	45
Usability degree	%	99	99
Number of power degrees		3	3
Power degrees division	kW	16+16+8	18+18+9
Mains power		V AC 3N ~ 400/230V 50Hz	
Protection level		IP40	
Needed fuses	A	63	80
Cable cross-section Minimum	mm ²	5×16	5×25
Allowed working pressure max	bar	3.0	
Allowed working pressure min	bar	0.5	
Boiler temperature max	°C	80	
Water volume in boiler	ℓ	32	32
Input cable connection		DN30	DN30
Returning cable connection		DN30	DN30
Device mass (Without water)	Kg	31	32

Table 4b: Technical data EI-Cm Basic 40-45 kW

4. Device installation



CAUTION: Human or material damage for irregular installation!

- ④ Never install the boiler without expansion dish (AG) and safety valve
- ④ Must not install the boiler in protective zone of moist area or area where the bathtub is placed



NOTE: Material damage due to freezing!

- ④ Install the boiler only in rooms protected against freezing

4.1 Caution when installing



NOTE: Material damage due to nonconformity with further instructions!

- ④ Follow up with instructions for the boiler and all installed components

Before installing:

- All electrical connections, protective measures and fuses should be executed only by authorized person complying with all valid norms and regulations
- Electrical connection should be done in accordance with connecting schemes
- After proper installing there should be executed device grounding
- Before opening device and all works turn off electric power
- Unprofessional and unauthorized attempts of connecting with power on can result in material damage on device and lead to dangerous electric power shocks

4.2 Distances



DANGER: Fire hazard due to ignitable materials or liquids!

- Do not dispose ignitable materials or liquids in the vicinity of boiler
- Do inform users about valid regulations for minimum distances with ignitable materials (Section 2.8, p. 7).

- Comply with regulations about electric installations and minimum distances that are valid in certain countries
- Place boiler on a wall with free space as illustrated in the Figure 2

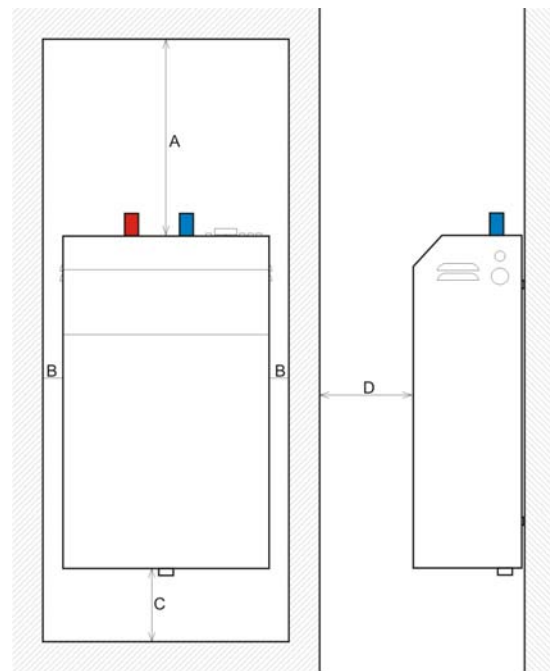

Figure 2: Minimum distances when installing

A = 500mm / B = 50mm / C = 200mm / D = 500mm

4.3 Front casing demounting

Front casing of the boiler can be removed for simple handling and installation.

- ④ unscrew 2 bolts on lid.
- ④ slowly pull up and remove front casing of the boiler

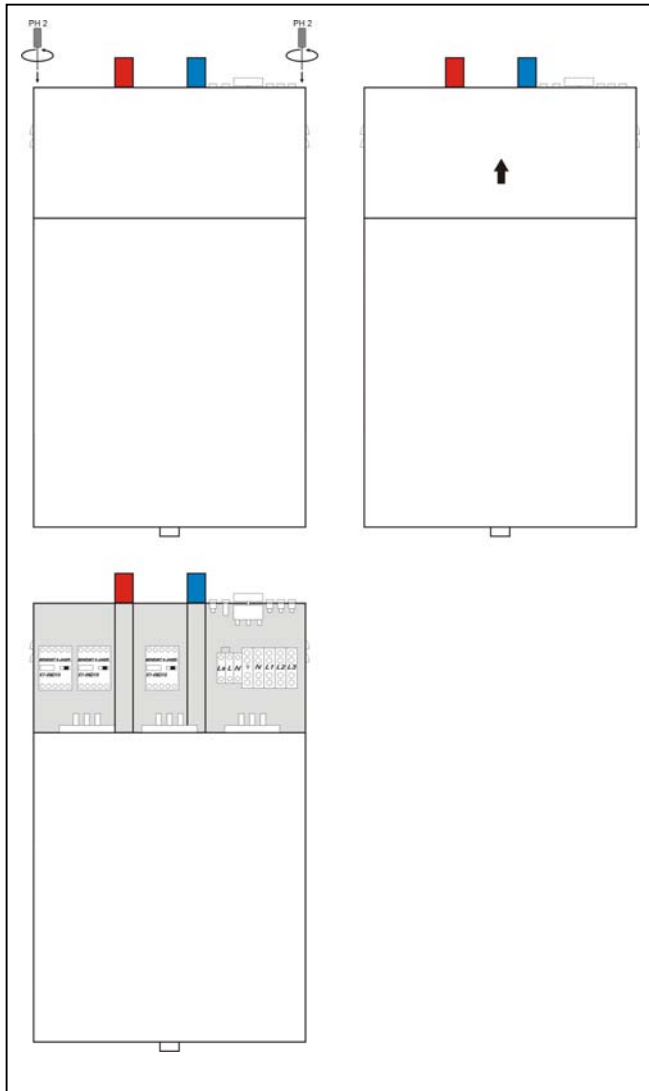

Figure 3: Opening the boiler (Demounting front casing)

4.4 Installing the boiler



NOTE: Material damage occurred due to irregular installation on the wall!

- ④ It is necessary to use corresponding material for fixing

This section describes boiler installation on the wall

- ④ Draw positions for drilling the holes for mounting set respecting minimum distances (Figure 3).
- ④ Drill holes according to dimensions in the Figure 2.
- ④ Place plastic anchors into drilled holes and enclosed in the package (or those adequate for nonstandard wall)
- ④ Screw enclosed bolts into the anchors (or some other kind) and leave them out of wall min 5mm and max 10mm
- ④ Hang device carefully on the wall
- ④ Make sure that boiler is in vertical position
- ④ Fix the boiler on the wall with mounting set and bolt.

4.5 Hydraulic connections



NOTE: Material damage caused by permeable connections!

- ④ Install connecting ducts with no connecting to boiler connections

Connect heating connections in the following way:

- ④ Connect returning duct to connection IN
- ④ Connect input connection to connection OUT.

4.6 Filling the installations and permeability testing

4.6.1 Filling the boiler with heating water and test sealing

- ④ It is necessary to test permeability before commissioning the boiler



DANGER: Injuries and/or material damage can occur due to overpressure when testing permeability!

High pressure can damage regulatory and safety devices and even tank.

- ④ After filling, fill the boiler with pressure corresponding to safety valve opening pressure.
- ④ Comply with maximum pressure in installed components.
- ④ After permeability testing open again shut-off valves.
- ④ Make sure that all pressure, regulation and safety parts work correctly



DANGER: Health hazard due to mixing drinking water!

- ④ It is mandatory to respect regulations and norms for avoiding mixing drinking water (e.g. with water from the heating installations). Comply with EN 1717.



NOTE: Material damage due to temperature stress.

When fill the boiler in warm condition, temperature stress can cause cracks due to tense.

- ④ Fill the boiler in cold condition (temperature of input duct must be 40 °C maximum).
- ④ Fill the boiler only via quick valve on the pipeline installation (returning duct) of the boiler



NOTE: Damage on installations due to bad water quality! Heating installations can be damaged by corrosion or calcification depending on water quality

- ④ Respect requests for filling water in accordance with VDI2035, or project documentation and catalogue

- ④ Check the sub-pressure of expansion dish

- ④ Open the faucet for filling/emptying

- ④ Slowly fill the boiler. Monitor pressure increase

When working pressure is reached, close the faucet

- ④ Execute air vent of the installation through valve on radiator

- ④ When working pressure decreases by air vent, water must be re-filled

- ④ Test permeability in accordance with local regulations

- ④ After permeability testing, open all elements you have closed due to filling

- ④ Check if all safety elements work correctly

- ④ If the boiler is tested on permeability and there were not spotted any leaking, then adjust correct working pressure.

- ④ Remove hose from the filling/emptying faucet

- ④ Enter values of working pressure and water quality into instructions for handling.

With first or repeated filling or with replacing the water

- ④ Comply with requests for filling water

4.6.2 Heating pump air vent and unlocking

- ④ This device has no circulation pump

When external pump for heating is locked, make the following:

- ④ Carefully try to unlock the pump axis using corresponding screwdriver.

4.6.3 Boiler and installation air vent

- ④ This device has no installed air vent.

- ④ On the installation must be installed air vent.

5. Electric connection

DANGER: Life threat for electric power shock!

- ④ Execute electric works only with necessary qualifications.
- ④ Before opening device turn off the mains voltage on all poles and secure against accidental turn on.
- ④ Comply with installing regulations

When connecting the boiler to electric installation take care of connecting scheme. Respect mandatory cross-sections of cables and fuse power out of the boiler.

This device is intended to connection on three-phases electric network (3N ~ 400/230V 50Hz)
It is possible to connect on one-phase network only devices with power of 6 and 9 kW, while cross-section of connecting cable must be in accordance with Table X.

5.1 Positions of cable plug-in for connecting voltage cable

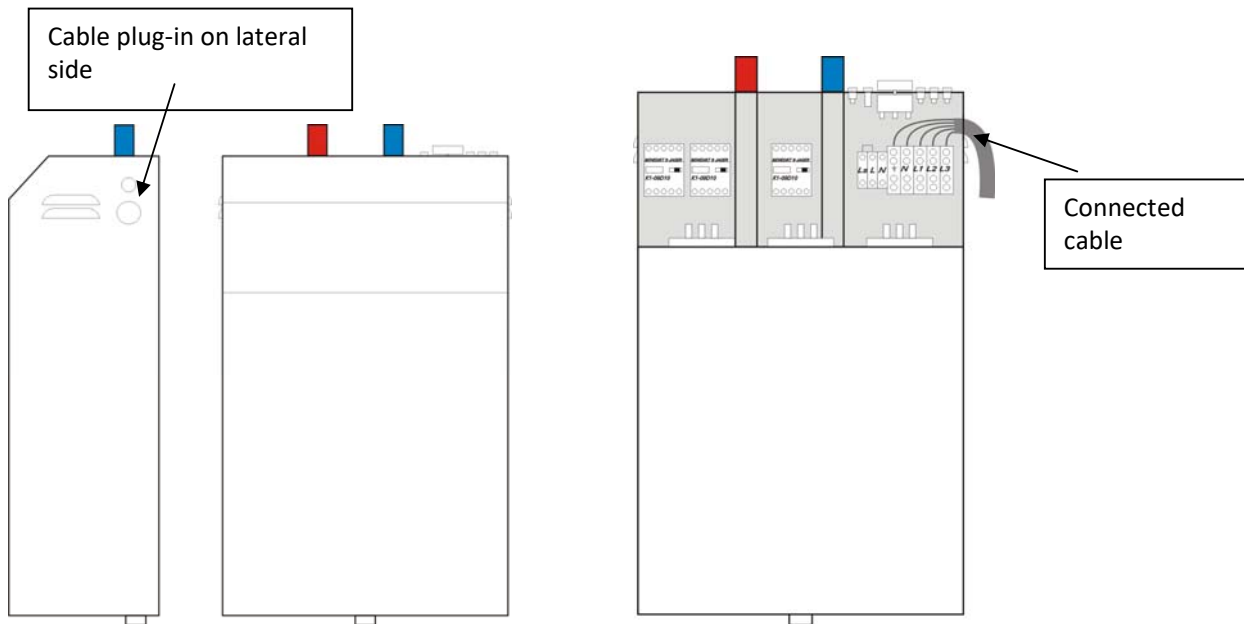

Figure 4: Illustration of cable plug-in positions on the boiler

THREE-PHASE POWER SUPPLY

3N ~ 400/230V 50Hz	Basic 6	Basic 9
In[A]	3 × 8,7	3 × 13,1
Fuses [A]	3 × 16	3 × 20
Min. cable cross-section	5×2,5mm ²	5×2,5mm ²

ONE-PHASE POWER SUPPLY

1N ~ 230V 50Hz	Basic 6	Basic 9
In[A]	1 × 26,2	1 × 39,3
Fuses [A]	1 × 32	1 × 50
Min. cable cross-section	3×4mm ²	3×6mm ²

Table 5a: Nominal power, necessary electric fuses and cross-section of power cables with boilers of 6 and 9 kW
For three-phase and mono-phase power supply

3N~400/230V 50Hz	Basic 12	Basic 18	Basic 24	Basic 27	Basic 30	Basic 36	Basic 40	Basic 45
In[A]	3 × 17,4	3 × 26,2	3 × 34,8	3 × 39,3	3 × 43,5	3 × 52,2	3 × 58	3 × 72,5
Fuses [A]	3 × 25	3 × 32	3 × 40	3 × 50	3 × 50	3 × 63	3 × 63	3 × 80
Min. cable cross-section	5×4mm ²	5×4mm ²	5×6mm ²	5×6mm ²	5×10mm ²	5×10mm ²	5×16mm ²	5×25mm ²

Table 6: Nominal power, necessary electric fuses and cross-section of power cables for three-phase power supply

5.2 Connecting voltage cable

- Connecting shall be done in accordance with scheme given in the Figure no. 7.
- To connect voltage cable there are planned line clamps of corresponding boiler power.
- To connect room thermostat and circulation pump there are planned ancillary working clamps.



WARNING! When connecting phase guides it is mandatory to tight bolts in line clamps to achieve as better as possible connection between guide and clamp.



DANGER! If good connection between guide and clamp is not good it can make uncontrolled clamp warming and its failure.



NOTE! Only professional and qualified person for such jobs must execute this device connecting.

- Neutral (zero) guide is connected on corresponding line clamp (N). The line clamp of zero ducts is in blue color.
- Guides for grounding should be connected in middle clamp labeled with grounding symbol. Line clamp of device grounding duct is in green color.
- When connecting voltage cable on the boiler, carefully pull the cable to the line clamps and take care not to damage cables inside the device.



NOTE: Room thermostat is to be connected on line clamps.

- It is necessary to apply room thermostat with non-voltage contacts, for clamps predicted for connecting has the voltage of 230V, 50Hz.
- Recommendation: Connect room thermostat with seven days programming achieving comfortable heating and energy savings.

5.3. Voltage cable connecting scheme

5.3.1 Voltage cable connecting scheme for three-phase power supply

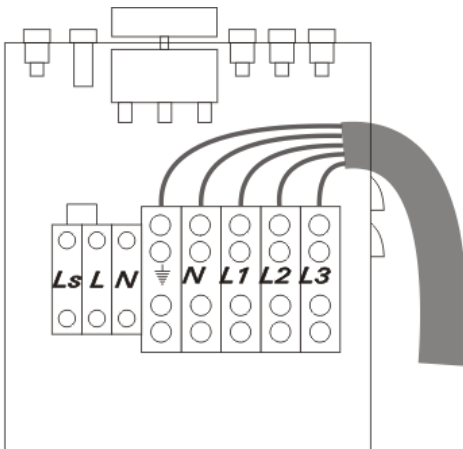

Figure5: Voltage cable connecting scheme for three-phase power supply

5.3.2 Voltage cable connecting scheme for mono-phase power supply

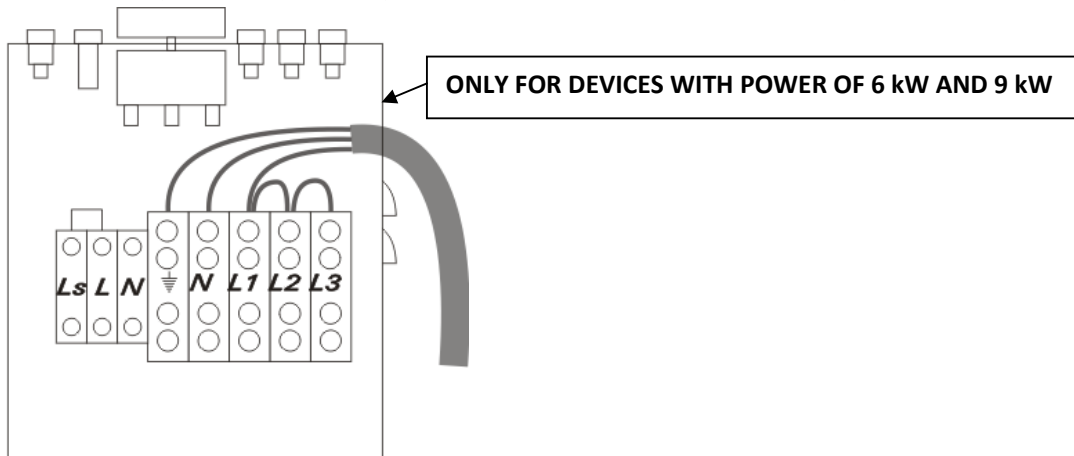
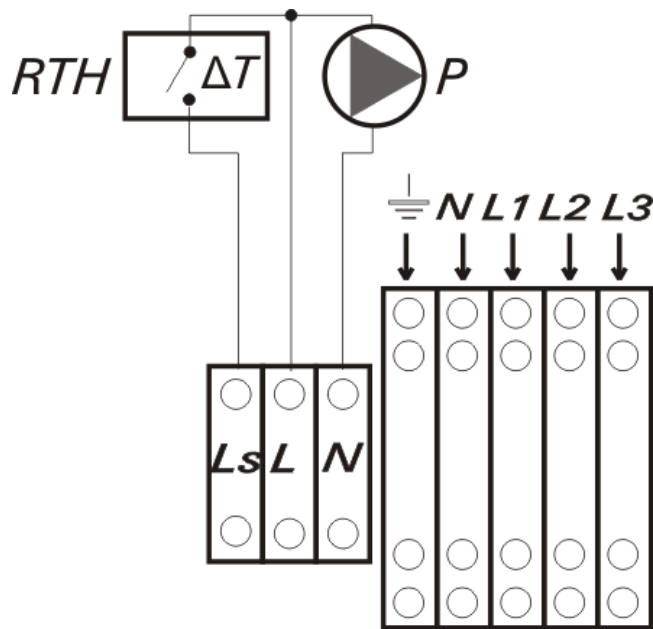

Figure 6: Voltage cable connecting scheme for mono-phase power supply

5.4. Connecting of external boiler control (room thermostat)

5.4.1 Connecting boiler remote control (room thermostat)



The room thermostat connected in such mode controls the boiler operations, or the boiler is OFF when given temperature is achieved on the room thermostat.

Circulation pump is connected in a way that can work continuously after the main switcher on boiler is ON (ON/OFF).

Figure 7: Room thermostat controls the boiler work, pump works directly via ON/OFF switcher

5.4.2 Connecting remote control (room thermostat) for boiler and circulation pump

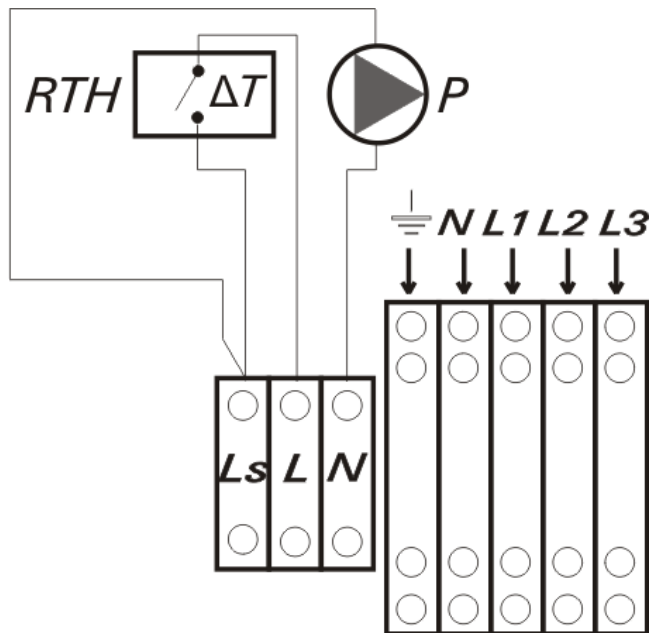

The room thermostat connected as such controls the boiler and circulation pump work meaning that boiler and pump are OFF when the given temperature is achieved on the room thermostat.

Figure8: Room thermostat controls work of boiler and pump

5.5 Electric schemes



All quoted cable cross-sections are minimum cross-sections. The needed cross-sections depend on duct length and mode of installation

- ④ Cable cross-sections should be dimensioned in accordance with local regulations.

Legend	
PE	Connecting clamp of protecting guide
N, L1, L2, L3	Connecting clamps of voltage cable
RTH	Room thermostat (230V AC; 2A)
Ls, L, N	Connecting clamps of room thermostat
STB	Safety melting thermostat (103°C,4A) – Protection of the boiler control circle
TH	Working thermostat (20÷80°C,16A)
e	Signal lamp of economic condition
RK1, RK2, RK3	Relay contactor (For 9 kW , 12 kW and 18 kW)
K1, K2, K3, K4, K5	Contactor (For 24 kW , 27 kW , 30 kW , 36 kW , 40 kW and 45 kW)
G1	Heater -3×1500W for boiler power: 9 kW -3×2000W for boiler power: 6, 12, 18, 30, 36 kW -3×2667W for boiler power: 24, 40 kW -3×3000W for boiler power: 27, 45 kW
G2	Heater -3×1500W for boiler power: 9 kW -3×2000W for boiler power: 12, 18, 30 kW -3×2667W for boiler power: 24, 40 kW -3×3000W for boiler power: 27, 36, 45 kW
G3	Heater -3×2000W for boiler power: 18, 30, 36 kW -3×2667W for boiler power: 24, 40 kW -3×3000W for boiler power: 27, 45 kW
G4	Heater -3×2000W for boiler power: 30 kW -3×2667W for boiler power: 40 kW -3×3000W for boiler power: 36, 45 kW
G5	Heater -3×2000W for boiler power: 30, 36 kW -3×2667W for boiler power: 40 kW -3×3000W for boiler power: 45 kW

Table 4: Legend of joining and connecting schemes EI-Cm Basic

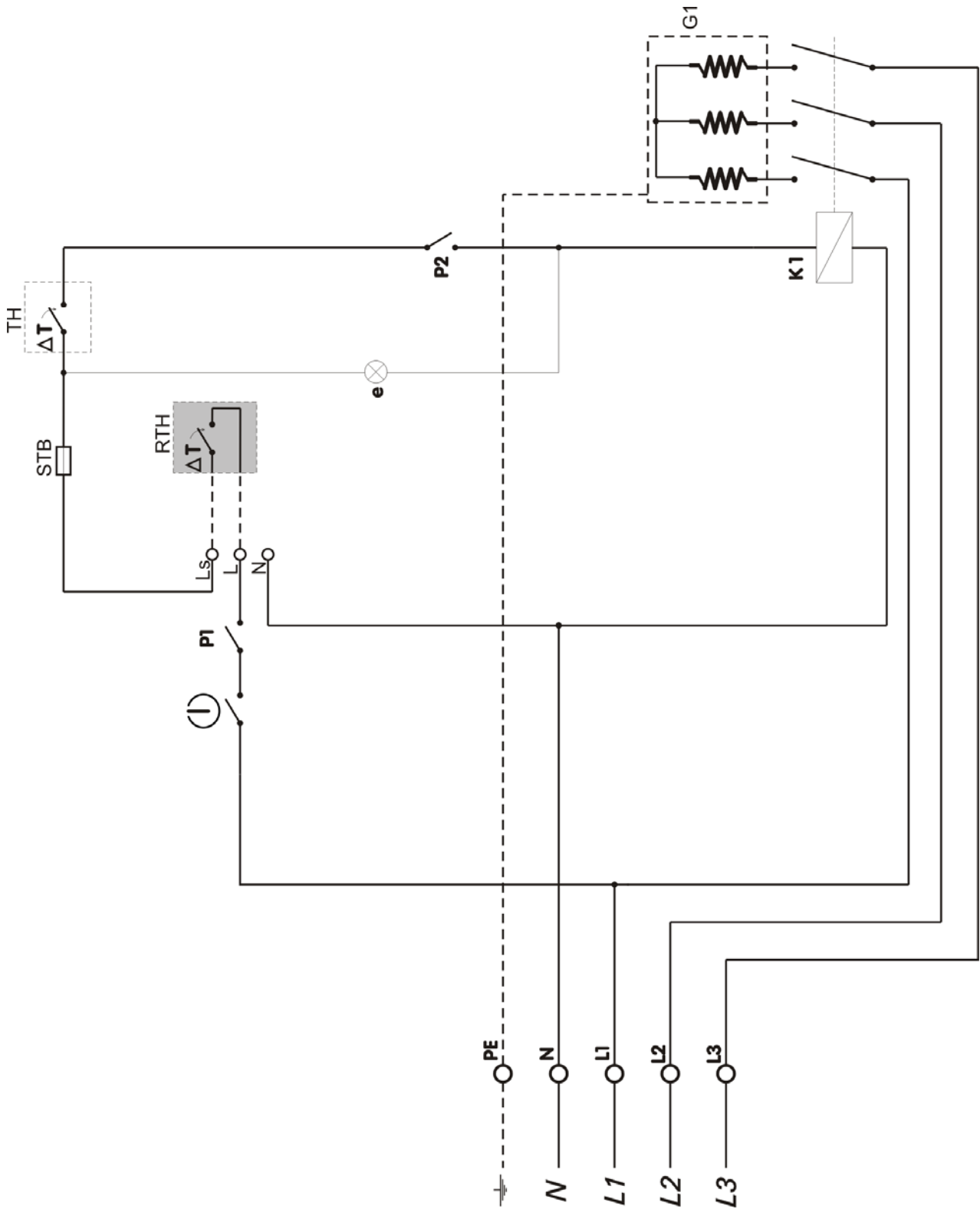

Figure 9: Electric scheme for boiler BASIC nominal power of 6 kW

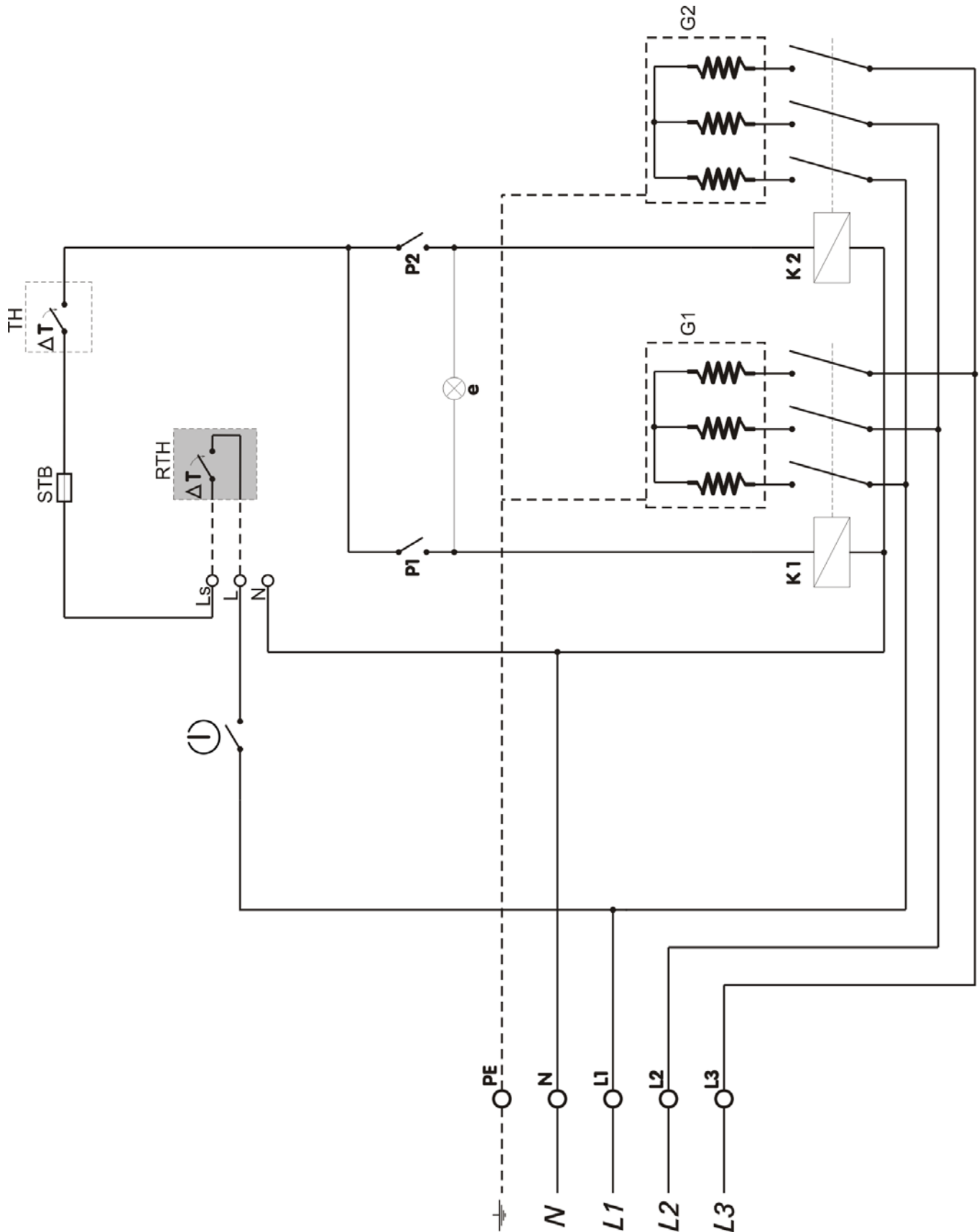

Figure 10: Electric scheme for boiler BASIC nominal power of 9 kW and 12 kW

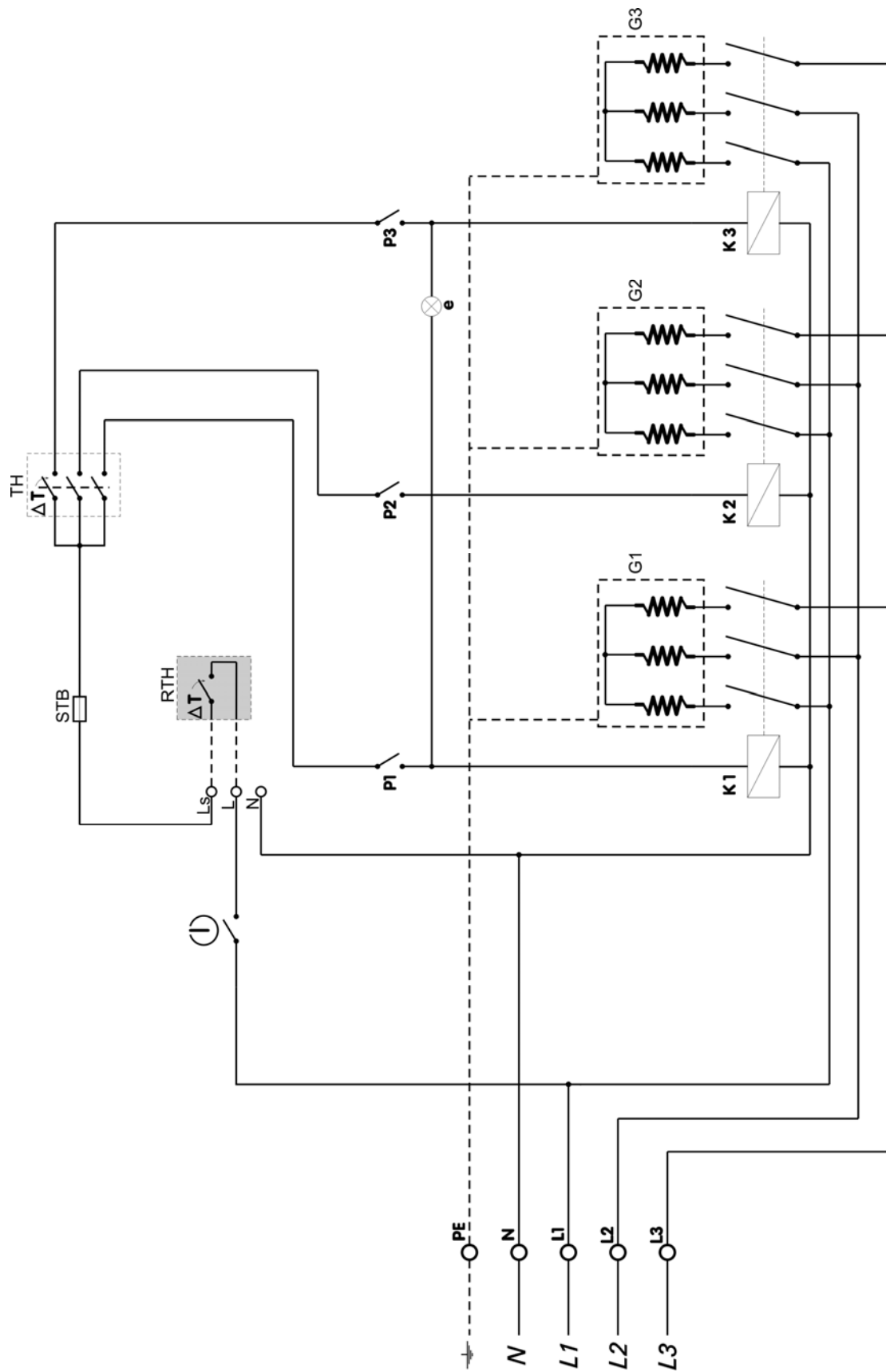

Figure 11: Electric scheme for boiler BASIC nominal power of 18 kW, 24 kW and 27 kW

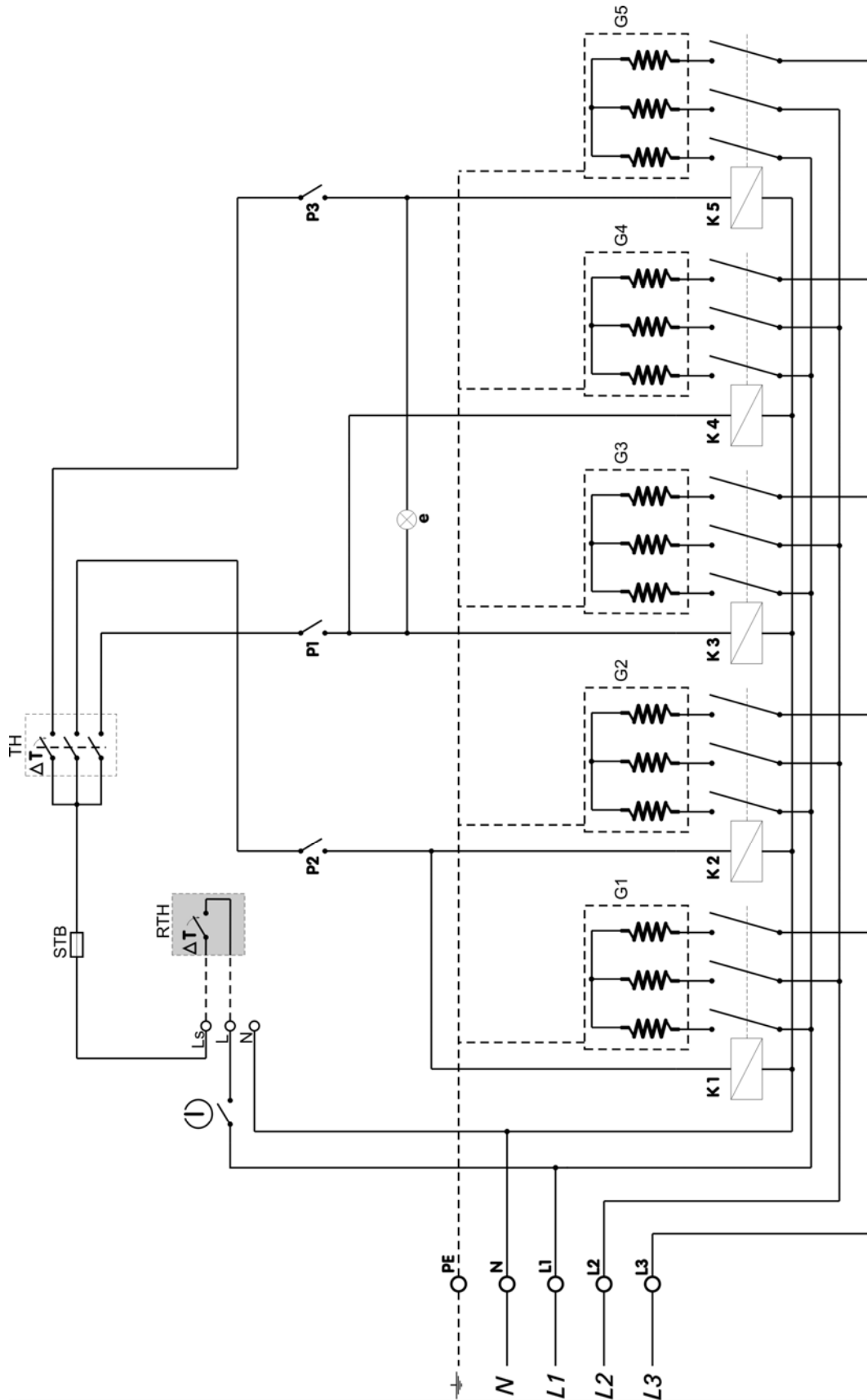

Figure 12: Electric scheme for boiler BASIC nominal power of 30, 40, and 45 kW

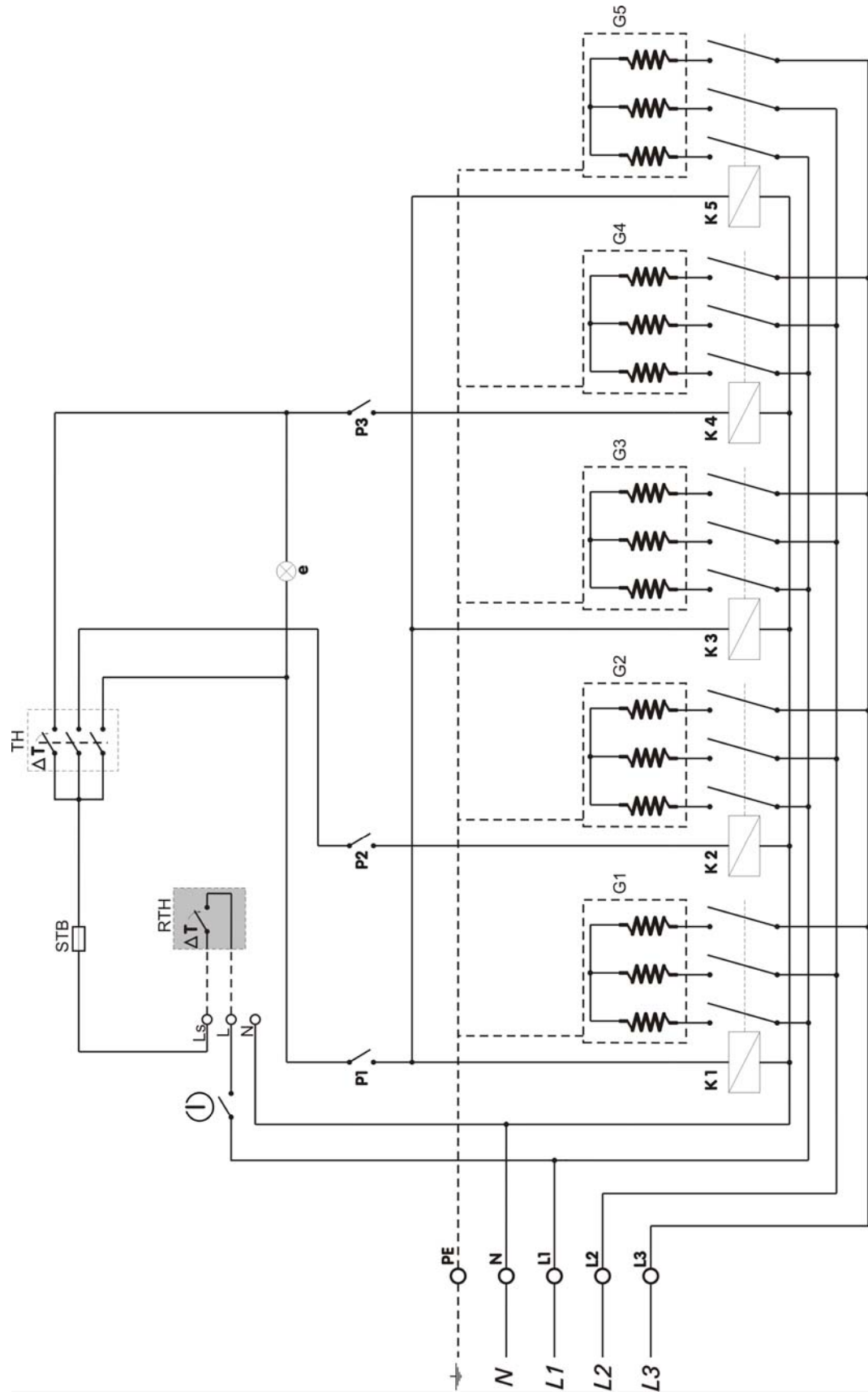

Figure 13: Electric scheme for boiler BASIC nominal power of 36 kW

6. Commissioning

After execution of the following works please fill in the Minute Book on Commissioning (Section 6.3)

6.1 Before commissioning



NOTE: Material damage occurred due to unprofessional handling!
Commissioning with insufficient water quantity shall destroy device.

- ④ Always turn on the boiler and use only if there is sufficient quantity of water.



Boiler must work with minimum pressure of 0, 5 bar

Before commissioning check if the following elements are properly connected and working properly:

- Impermeability of heating installations
- All pipes connected to ducts
- All electric connections

6.3 Minute Book on Commissioning

	Commissioning works	Page	Measuring values	Notes
1.	Type of boiler			
2.	Serial number			
3.	Adjusted regulation		<input type="checkbox"/>	
4.	Heating installation filled and air vent with checked permeability of all connections	16	<input type="checkbox"/>	
5.	Established working pressure • Checked pressure of expansion dish		<input type="checkbox"/> _____ bar <input type="checkbox"/> _____ bar	
6.	Inspected safety devices	16	<input type="checkbox"/>	
7.	Electric connection installed in accordance with local regulations	16	<input type="checkbox"/>	
8.	Functions checked	16	<input type="checkbox"/>	
9.	Users informed about the boiler work and technical documentation handed over		<input type="checkbox"/>	
10.	Confirmation of professional commissioning		Service seal / signature/ date	

Table 5: Minute Book on Commissioning

6.2 First commissioning



NOTE: material damage occurred due to irregular handling!

- ④ Inform client/user how to handle this device

- ④ Before first commissioning check if the heating installation is filled with water and vent.
- ④ Turn on main switcher (Bottom side of device)
- ④ Turn on heating system circular pump
- ④ Turn on heater switcher
- ④ Adjust working temperature using thermostat

7. Handling heating installation

7.1 Work instruction

Safety instructions

- ④ Make sure the boiler is managed only by adults familiar with instructions and boiler work modes.
 - ④ Take care that children do not stay in the area of the boiler without control
 - ④ Do not dispose or store combustible objects within safety distance of 400m around boiler.
 - ④ Combustible objects must not be placed on boiler.
 - ④ User must respect work instructions.
 - ④ User must just turn on the boiler (except first commissioning), adjust temperature on regulation and turn off the boiler. All other works must be done by authorized servicer.
 - ④ Authorized person that executed installation is obliged to inform users about handling and correct safe work of the boiler.
 - ④ In case of emergency regarding explosion, fire, gas or steam leaking the boiler must not work.
 - ④ Take care of combustible features of composition elements (☞ Instructions for installing and maintenance)
-

7.2 Regulatory elements BASIC 6/9/12 kW

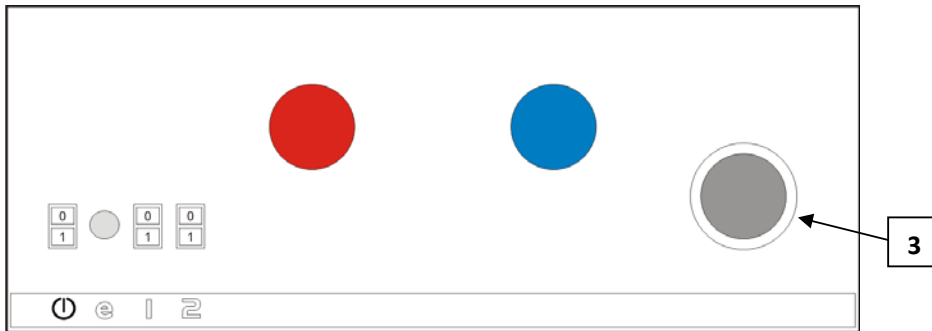

BASIC 6 kW

⏻ - Main switcher – Turning ON device.

1 - Switcher 1 – Possible turn on of external circulation pump and condition for heater turning on.

2 - Switcher 2 – Turning on heater of 6 kW,
Via working and room thermostat
(Safety diode in it indicates heater work)

e – Signal diode (Between switcher ⏻ and switcher 1)
Signaling economic condition – achieved given temp.

3 – Working thermostat - for temperature selection in boiler. Recommendation: Adjust work temperature of boiler within economic range of 50°C - 70°C

⏻	1	2	kW
1	0	0	0
1	1	0	0
1	0	1	0
1	1	1	6

Power selection by Basic 6 kW combination
Of switchers on control panel

BASIC 9 kW

⏻ - Main switcher – Turning ON device and possibility to turn on external circulation pump.

1 – Switcher 1 – Turning on heater I with power of 4.5 kW
Via working and room thermostat
(Signaling diode in it indicates heating group work).

2 - Switcher 2 – Turning on heater II with power 4.5 kW
Via working and room thermostat
(Signaling diode in it indicates heating group work).

e - Signal diode (Between switcher ⏻ and switcher 1)
Signaling economic condition – boiler works with reduced power

3 – Working thermostat - for temperature selection in boiler. Recommendation: Adjust work temperature of boiler Within economic range: 50°C - 70°C

⏻	1	2	kW
1	0	0	0
1	1	0	4,5
1	0	1	4,5
1	1	1	9

Power selection by Basic 9 kW combination
Of switchers on control panel

BASIC 12 kW

⏻ - Main switcher – Turning ON device and possibility to turn on external circulation pump.

1 - Switcher 1 – Turning on heater I with power of 6kW
Via working and room thermostat,
(Signaling diode in it indicates heating group work.

2 - Switcher 2 – Turning on heater II with power of 6kW
Via working and room thermostat,
(Signaling diode in it indicates heating group work)

e- Signal diode (Between switcher ⏻ and switcher 1)
Signaling economic condition – boiler works with Reduced power

3 - Working thermostat - for temperature selection in boiler. Recommendation: Adjust work temperature of boiler within economic range: 50°C - 70°C

⏻	1	2	kW
1	0	0	0
1	1	0	6
1	0	1	6
1	1	1	12

Power selection by Basic 12kW combination
Of switchers on control panel

7.2 Regulatory elements BASIC 18/24/27 kW

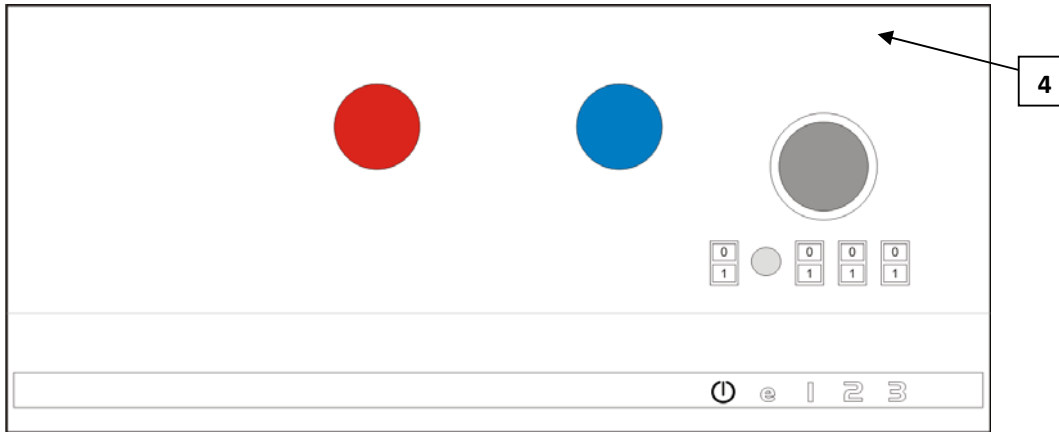

BASIC 18k W

⏻ - Main switcher – Turning ON device and possibly to turn on external circulation pump.

- 1 - Switcher 1 – Turning on heater I with power of 6 kW
Via working and room thermostat,
(Signaling diode in it indicates heater work).
- 2 - Switcher 2 – Turning on heater II with power of 6 kW
Via working and room thermostat,
(Signaling diode in it indicates heater work).
- 3 - Switcher 3 – Turning on heater III with power of 6 kW
Via working and room thermostat,
(Signaling diode in it indicates heater work).

e – Signal bulb (between switcher ⏻ and switcher 1)
Signaling economic condition – boiler works with reduced power.

4 – Working thermostat - for temperature selection in boiler.
Thermostat is three-grade, turns on/off heaters one by one each 5°C. As such it eliminates shocks to electric network and provides more accurate achievement and maintenance of work temperature. Recommendation: adjust boiler temperature within economic range of 50°C - 70°C

BASIC 24 / 27 kW

⏻ - Main switcher – Turning ON device and possibility to turn on external circulation pump.

- 1- Switcher 1 – Turning on heater I with power of 8/9 kW
Via working and room thermostat
(Signaling diode in it indicates heater work).
- 2 2-Switcher 2 – Turning on heater II with power of 8/9 kW
Via working and room thermostat
(Signaling diode in it indicates heater work).
- 3 3-Switcher 3 – Turning on heater III with power of 8/9 kW
Via working and room thermostat,
(Signaling diode in it indicates heater work).

e – Signaling diode (between switch ⏻ and switch 1)
Signaling economic condition – boiler works with reduced power.

4 – Working thermostat - for temperature selection in boiler.
Thermostat is three-grade, turns on/off heaters one by one each 5°C. As such it eliminates shocks to electric network And provides more accurate achievement and maintenance Of work temperature. Recommendation: adjust boiler Temperature within economic range of 50°C - 70°C

⏻	1	2	3	BASIC - 18 kW	BASIC - 24 kW	BASIC - 27 kW
1	0	0	0	0	0	0
1	1	0	0	6	8	9
1	0	1	0	6	8	9
1	0	0	1	6	8	9
1	1	1	0	12	16	18
1	1	0	1	12	16	18
1	0	1	1	12	16	18
1	1	1	1	18	24	27

Power selection
By BASIC 18, 24, 27 kW
Combination of
switchers

7.2 Regulatory elements BASIC 30/36 kW

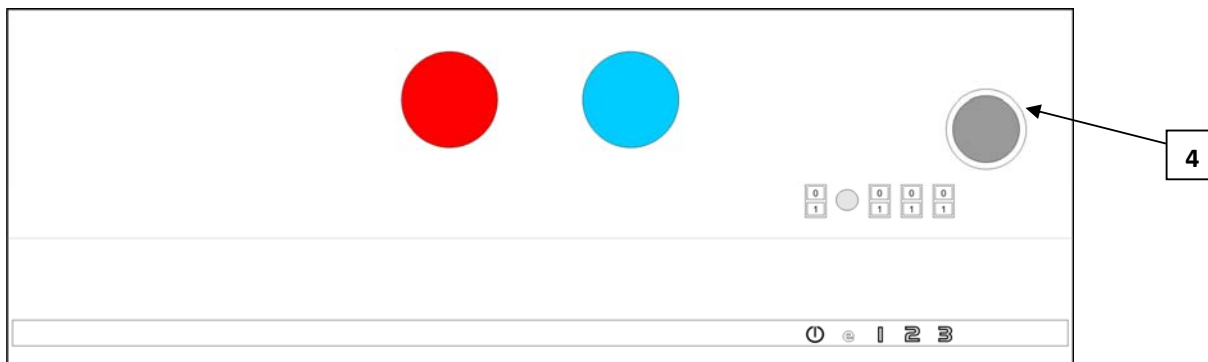

BASIC 30 kW

⏻ - Main switcher – Turning ON device and possibility to turn on external circulation pump.

- 1 - Switcher 1 – Turning on heater I power group of 12 kW
Via working and room thermostat,
(Signaling diode in it indicates heater group work).
- 2 - Switcher 2 – Turning on heater II power group of 12 kW
Via working and room thermostat,
(Signaling diode in it indicates heater group work).
- 3 – Switcher 3 – Turning on heater III power group of 6 kW
Via working and room thermostat,
(Signaling diode in it indicates heater work).

e – Signal bulb (between switcher ⏻ and switcher 1)
Signaling economic condition – boiler works with Reduced power

4 – Working thermostat - for temperature selection in boiler.
Thermostat is three-grade, turns on/off heaters one by one each 5°C. It eliminates shocks to electric network and provides more accurate achievement and maintenance of work temperature. Recommendation: adjust boiler temperature within economic range of 50°C - 70°C

BASIC 36 kW

⏻ - Main switcher-Turning ON device and possibility to turn on external circulation pump.

- 1 - Switcher 1 – Turning on heater I power group of 18 kW
Via working and room thermostat.
(Signaling diode in it indicates heater group work).
- 2 - Switcher 2 – Turning on heater II power group of 9 kW
Via working and room thermostat.
(Signaling diode in it indicates heater group work).
- 3 – Switcher 3 – Turn on heater III power group of 9kW
via working and room thermostat.
(Signaling diode in it indicates heater group work).

e – Signal diode (between switcher ⏻ and 1)
Signaling economic condition – boiler works with Reduced power.

4 – Working thermostat – for temperature selection in Boiler. Thermostat is three-grade, turns on/off heaters one by one each 5°C. It eliminates shocks to electric Network and provides more accurate achievement and Maintenance of work temperature. Recommendation: Adjust boiler temperature within economic range of 50°C - 70°C

⏻	1	2	3	BASIC - 30 kW	BASIC - 36 kW
1	0	0	0	0	0
1	1	0	0	12	18
1	0	1	0	12	9
1	0	0	1	6	9
1	1	1	0	24	27
1	1	0	1	18	27
1	0	1	1	18	18
1	1	1	1	30	36

Power selection
By BASIC 30 and 36kW
Combination of switchers

7.2 Regulatory elements BASIC 40/45 kW

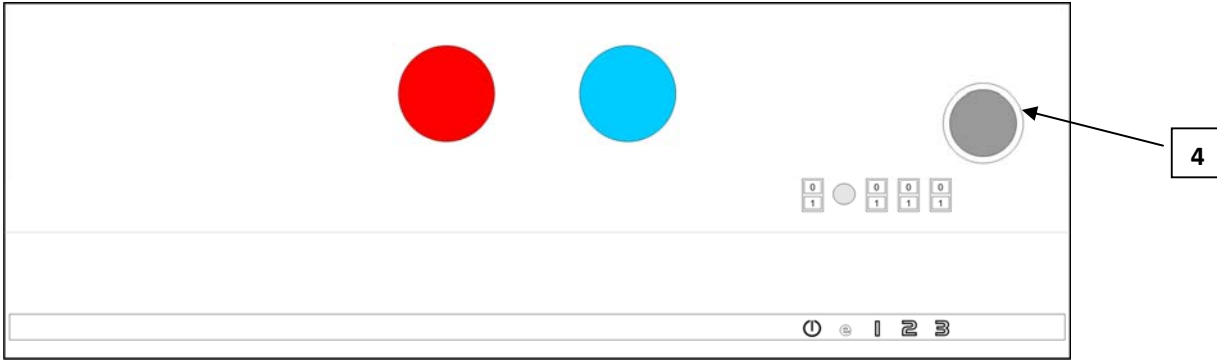

BASIC 40 kW

⏻ - Main switcher-Turning ON device and possibility to turn on external circulation pump.

- 1 - Switcher 1 – Turning on heater I power group of 16 kW via working and room thermostat, (Signaling diode in it indicates heater group work).
- 2 - Switcher 2 – Turning on heater II power group of 16 kW via working and room thermostat, (Signaling diode in it indicates heater group work).
- 3 – Switcher 3 – Turning on heater III power group of 8 kW via working and room thermostat, (Signaling diode in it indicates heater work).
- e – Signal bulb (between switcher ⏻ and switcher 1) signaling economic condition – boiler works with reduced power
- 4 – Working thermostat - for temperature selection in boiler.

Thermostat is three-grade, turns on/off heaters one by one each 5°C. It eliminates shocks to electric network and provides more accurate achievement and maintenance of work temperature. Recommendation: adjust boiler temperature within economic range of 50°C - 70°C

BASIC 45 kW

⏻ - Main switcher-Turning ON device and possibility to turn on external circulation pump.

- 1 - Switcher 1 – Turn on heater I power group of 18 kW via working and room thermostat, (Signaling diode in it indicates heater group work).
- 2 - Switcher 2 – Turn on heater II power group of 18 kW via working and room thermostat, (Signaling diode in it indicates heater group work).
- 3 – Switcher 3 – Turn on heater III power group of 9kW via working and room thermostat, (Signaling diode in it indicates heater group work).
- e - Signaling diode (between switcher ⏻ and 1) signaling economic condition – boiler works with reduced power

4 – Working thermostat – for temperature selection in boiler. Thermostat is three-grade, turns on/off heaters one by one each 5°C. It eliminates shocks to electric network and provides more accurate achievement and maintenance of work temperature. Recommendation: adjust boiler temperature within economic range of 50°C - 70°C

⏻	1	2	3	BASIC - 40 kW	BASIC - 45 kW
1	0	0	0	0	0
1	1	0	0	16	18
1	0	1	0	16	18
1	0	0	1	8	9
1	1	1	0	32	36
1	1	0	1	24	27
1	0	1	1	24	27
1	1	1	1	40	45

Power selection
By BASIC 40 and 45kW
Combination of switchers

7.3. Room thermostat

This device is not predicted for work without room thermostat. It must be installed in reference room. Temperature control in all rooms of the system is done via this remote controller. Radiators in the reference room should not be equipped with thermostat valves, or they always must be open. All radiators in other rooms must be equipped with thermostat valves. Connecting room thermostat is illustrated in the Section 5.4. When installing room thermostat in reference room follow up with thermostat manufacturer instructions.

7.4. Heating interruption

With short-term interruption of heating the boiler temperature must be reduced using thermostat regulator. In order to prevent freezing of heating installation, boiler temperature must not be lower than 5 °C. With long-term interruption of heating the boiler temperature must be out switched off. (∅ Section 7.4).

7.5. Switch off the boiler

When heating installation is not working, it could freeze with low temperatures.

- ④ Protect heating installation against freezing
- ④ If there is risk of freezing, and boiler is off, empty the installations.
- ④ Put main switcher on bottom panel in **ZERO** position (turn off).

When device is in long-term state of rest the heating pump can be locked. To unlock the pump undertake the same procedure as with air vent.
(∅ Section 4.6.2)

8 Cleaning and maintenance



DANGER: Life threat for electric power shock!

- ④ Electric works may be done only if you are qualified.
- ④ Before device opening: Turn off heating installation from electric power supply using safety switcher of heating system, cut off the electric network through corresponding fuse.
- ④ Secure heating installation against accidental turn on
- ④ Follow up with installing regulations



WARNING: Material damage due to unprofessional maintenance!

Insufficient or unprofessional boiler maintenance can lead to damage and destruction of boiler and warranty rights misplace.

- ④ Secure regular, complete and professional maintenance of heating installations
- ④ Protect electric parts and working units against water and humidity



Use only original spare parts of manufacturer or alternative approved by manufacturer. There shall be no responsibility for damage occurred due to spare parts not supplied by manufacturer.



Minute Book on control inspection and maintenance is on the page 30

- ④ Execute works according to the Minute Book on control inspection and maintenance
- ④ Immediately remove defects.

8.1 Boiler cleaning

- ④ Clean external surfaces using wet cloth

8.2

Testing work pressure, refilling water and air vent of installations



DANGER: Health hazard because of mixing drinking water!

- ④ It is mandatory to respect state regulations and norms on avoiding mixing drinking water (e.g. with water from heating installations)
- ④ Comply with EN 1717



Establish working pressure of at least 0.5bar
Depending on installation height

Volume of fresh filled water is decreasing during first days after filling due to boiling. This produces air pillows making difficulties within the heating system.

Inspecting work pressure

- Work pressure of new heating installation should be controlled on daily basis at the beginning. If needed, add water and vent the heating system.
- ☑ Later check work pressure once a month. If needed, add water and vent the heating system.
- Check work pressure. If installation pressure decreases below 0.5bar it will be necessary to refill the water
- Refill the water
- Vent heating installations
- Check work pressure again

8.3 Refill water and vent installations



WARNING: Material damage due to temperature tense. Filling heating installations in hot condition can cause cracks due to tension.

- ④ Fill heating installations only in cold condition (temperature of input duct maximum 40 °C).



WARNING: Material damage due to often refilling!

Due to often water refilling, the heating installations can damage with corrosion and calcification depending on water features

- ④ Inspect heating installations on permeability and expansion dish on functional accuracy.

- Connect hose on water faucet
- Fill the hose with water and connect it on filling/emptying faucet
- Fix the hose with hose clamp and open the faucet for filling/emptying
- Fill slowly heating installation; Monitor manometer
- During the filling procedure vent the system**
- When the working pressure is reached close the faucet
- When working pressure is decreased by vent procedure, the water must be refilled
- Remove hose from filling/emptying faucet

8.4 Minute Book on control inspection and maintenance



At least once a year execute maintenance or when control inspection shows the installation condition requesting maintenance.

Minute Book on commissioning, control inspections and maintenance serves as enclosure for copying.

④ Executed works within control inspection procedure should be notarized by signature and date.

Works of control inspection and maintenance when needed		Page	Date: ____	Date: ____	Date: ____
1.	Check installation condition		<input type="checkbox"/>	<input type="checkbox"/>	<input type="checkbox"/>
2.	Execute visual and functional control		<input type="checkbox"/>	<input type="checkbox"/>	<input type="checkbox"/>
4.	Establishing working pressure				
	<ul style="list-style-type: none"> • Test pre-pressure of expansion dish • working pressure set on ____ • Heating installation air vent. • Check of safety valve 				
5.	Clean water filter		<input type="checkbox"/>	<input type="checkbox"/>	<input type="checkbox"/>
6.	Check if there are damages on electric ducts		<input type="checkbox"/>	<input type="checkbox"/>	<input type="checkbox"/>
7.	Check if electric connections of boiler control are fixed and used elements are firm and if needed tight them		<input type="checkbox"/>	<input type="checkbox"/>	<input type="checkbox"/>
8.	Check boiler thermostat regulator function		<input type="checkbox"/>	<input type="checkbox"/>	<input type="checkbox"/>
9.	Check safety parts function		<input type="checkbox"/>	<input type="checkbox"/>	<input type="checkbox"/>
10.	Check function of room thermostat		<input type="checkbox"/>	<input type="checkbox"/>	<input type="checkbox"/>
11.	Check insulation of rod heaters		<input type="checkbox"/>	<input type="checkbox"/>	<input type="checkbox"/>
12.	Check function of grounding				
13.	Check insulation of electric cabinet		<input type="checkbox"/>	<input type="checkbox"/>	<input type="checkbox"/>
14.	Check function of heating pump		<input type="checkbox"/>	<input type="checkbox"/>	<input type="checkbox"/>
15.	Make final control of inspection works and document measuring and testing results		<input type="checkbox"/>	<input type="checkbox"/>	<input type="checkbox"/>
16.	Confirmation of professionally conducted control inspection		Seal/Signature	Seal/Signature	Seal/Signature

Table 7: Minute Book on control inspection and maintenance

9 Environment protection / Waste management

Environment protection is one of basic concepts of business. Quality of products, economic performance and environment protection represent to us equally valuable goals.

It is critical to adhere with law and regulations on environment protection. In order to protect environment while respecting economic concepts we use our best technique and materials.

Packaging

Regarding packaging, we stick to recycling systems that are specific for certain countries while providing optimal recycling process. All used materials for packaging do not harm the environment and are recyclable.

Old device

Old used devices contain valuable materials that can recycle again. Structures can be easily separated and plastic materials are labeled. In such way structures can be sorted and transported to recycling plant or disposal.

10. Troubles and Troubleshooting



Removing troubles on regulation and hydraulics must be executed by authorized company.



For repairs are used only original spare parts.

Trouble:	Description:	Cause:	Measure:
Boiler does not react after main switcher on.	Contactors not put on	<ul style="list-style-type: none"> - boiler is out of power supply - fuses in electric cabinet are off - possible loss of control phase - main fuse defect ON/ OFF 	<ul style="list-style-type: none"> - secure power supply voltage - turn on fuses - check fuses output if there are three phases - replace defect part
Boiler does not heat or heat insufficiently / heating pump works	Boiler does not supply hot water	<ul style="list-style-type: none"> - failure of 1 or 2 phases - to low boiler power - defect of some relay - defect of some heater 	<ul style="list-style-type: none"> - check if three phases work in boiler - check adjusted power of boiler - replace defect part - replace defect part
Boiler heats but is very noisy	Increased noise level during work	<ul style="list-style-type: none"> - air in the system - too low water flow - possible calcification on heater 	<ul style="list-style-type: none"> - check if system is ventilated and if not perform air vent - check boiler valves and open it - clean filter in front of boiler - take out heaters and clean them (this is not warranty included)
Boiler turns off quickly	Achieves set temperature too fast and turn off the work	<ul style="list-style-type: none"> - closed valves below the boiler - locked pump - defective heating pump 	<ul style="list-style-type: none"> - open valves - turn on pump rotor - replace defect part
Working pressure great oscillations	Too fast and too big changes of working pressure	<ul style="list-style-type: none"> - one valve closed - inadequate pressure in expansion dish - defective expansion dish 	<ul style="list-style-type: none"> - open valve - check pressure in expansion dish and if needed pump up the dish up to adequate value - replace defective part

Table 8: Troubles and Troubleshooting